

# INSTALLATION AND OPERATION MANUAL

## DIRECT STEAM STATIONARY KETTLES

MODELS: DL - 20, 30, 40, 60, 80, 100 GALLON

DP - 20, 30, 40, 60, 80, 100 GALLON

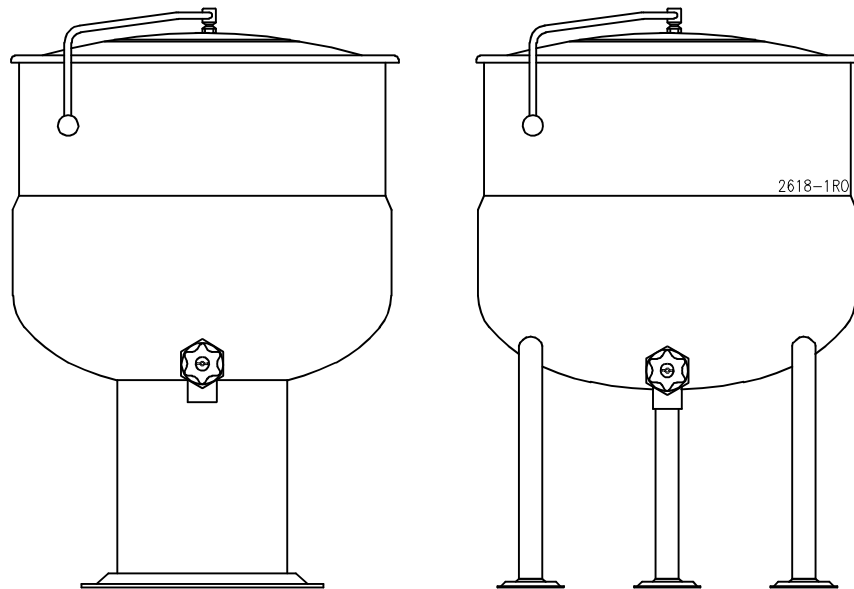

### CROWN FOOD SERVICE EQUIPMENT LTD.

70 OAKDALE ROAD, DOWNSVIEW, (TORONTO), ONTARIO, CANADA, M3N 1V9

TELEPHONE: (416) 746-2358 FAX: (416) 746-8324

PRINTED IN CANADA

INSTALLATION AND OPERATION MANUAL - DIRECT STEAM STATIONARY KETTLES,  
MODELS DL-20, 30, 40, 60, 80, 100 GALLON, DP-20, 30, 40, 60, 80, 100 GALLON

**IMPORTANT NOTES FOR INSTALLATION AND OPERATION**

It is recommended that this manual be read thoroughly and that all instructions be followed carefully.



**This is the safety alert symbol. It is used to alert you to potential personal injury hazards. Obey all safety messages that follow this symbol to avoid possible injury or death.**



**WARNING: Improper installation, operation, adjustment, alteration, service or maintenance can cause property damage, injury or death. Read the installation, operating and maintenance instructions thoroughly before installing, operating or servicing this equipment.**

**This manual should be retained for future reference.**

**Intended for commercial use only. Not for household use.**

**NOTICE: Contact the factory, the factory representative or local service company to perform maintenance and repairs.**

INSTALLATION AND OPERATION MANUAL - DIRECT STEAM STATIONARY KETTLES,  
MODELS DL-20, 30, 40, 60, 80, 100 GALLON, DP-20, 30, 40, 60, 80, 100 GALLON

**TABLE OF CONTENTS**

<b>DESCRIPTION</b>	<b>PAGE</b>
1.0 Service Connections .....	4
2.0 Installation Instructions .....	6
3.0 Introduction .....	7
4.0 Operating Instructions .....	8
5.0 Cleaning Procedures .....	9
6.0 Troubleshooting Maintenance .....	11

# INSTALLATION AND OPERATION MANUAL - DIRECT STEAM STATIONARY KETTLES, MODELS DL-20, 30, 40, 60, 80, 100 GALLON, DP-20, 30, 40, 60, 80, 100 GALLON

## 1.0 SERVICE CONNECTIONS

☁ - Steam supply: 3/4" IPS 5-30 psi (34-205 kPa). Optional 5-45 psi (34-310 kPa). \*

Ⓐ - Condensate return: 1/2" IPS

### DIMENSIONS

MODEL	CAPACITY		A	B	C	D	E	F(2")	F(3")	G(2")	G(3")	H	J	K
DL-20	20 U.S. gal.	inches	21	18	37	22.75	16	12.75	14	17	16.5	25.88	59.75	17.5
	76 litres	mm	533	457	940	578	406	324	356	432	419	657	1518	445
DL-30	30 U.S. gal.	inches	24	20	37	25.88	17.5	13.5	15.25	15	14.5	26.88	62.88	20.5
	114 litres	mm	610	508	940	657	445	343	387	381	368	683	1597	521
DL-40	40 U.S. gal.	Inches	26	22.5	37	27.88	18.5	14.25	16.5	12.5	12	23.88	64.88	22.5
	152 litres	mm	660	572	940	708	470	362	419	318	305	606	1648	572
DL-60	60 U.S. gal.	inches	29.5	26	40.5	31.38	17.75	15.5	17.25	12.5	12	24.69	72.88	25.75
	227 litres	mm	749	660	1029	797	451	394	438	318	305	627	1851	654
DL-80	80 U.S. gal.	inches	33	28	42.5	34.75	19.5	17.5	19.25	10.5	10	23.88	75.25	29.25
	303 litres	mm	838	711	1080	883	495	445	489	267	254	606	1911	743
DL-100	100 U.S. gal.	Inches	35.5	30	44.5	37.25	20.75	17	19.25	12.5	12	26.63	81.75	31.75
	379 litres	mm	902	762	1130	946	527	432	489	318	305	676	2076	806

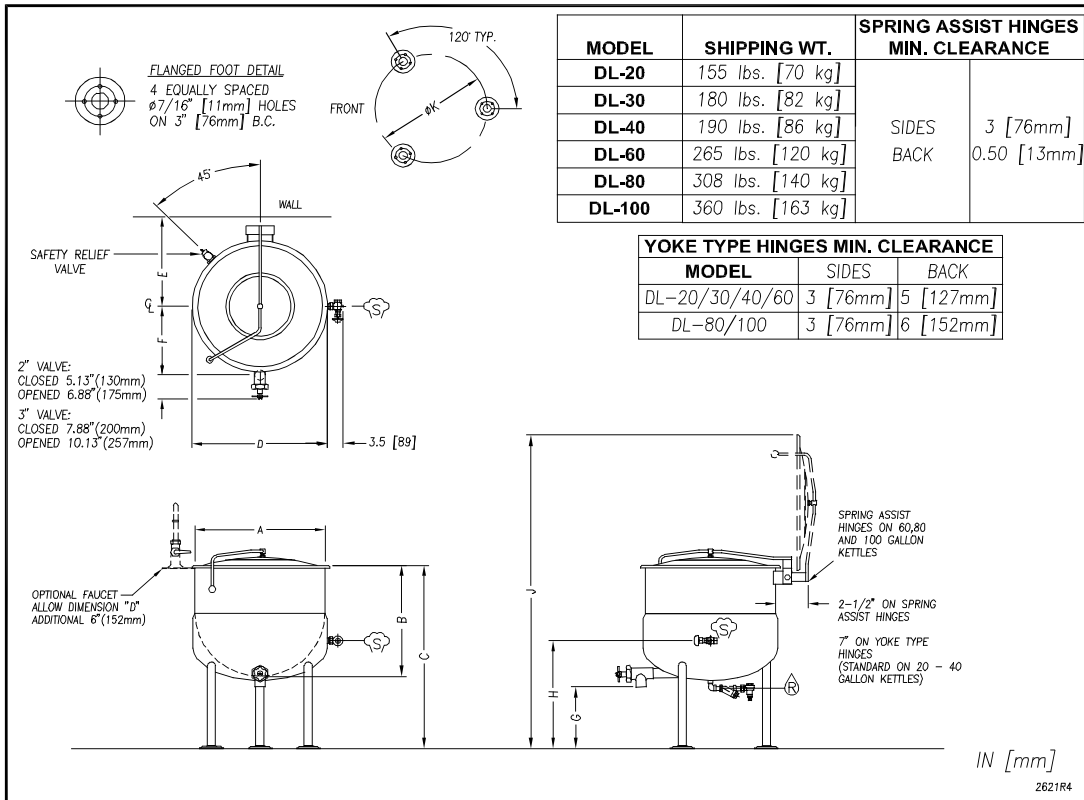

\* Pressure reducing valve is required if incoming pressure exceeds 50 PSI (345 kPa).



As continued product improvement is a policy of Crown, specifications are subject to change without notice.

# INSTALLATION AND OPERATION MANUAL - DIRECT STEAM STATIONARY KETTLES, MODELS DL-20, 30, 40, 60, 80, 100 GALLON, DP-20, 30, 40, 60, 80, 100 GALLON

## 1.0 SERVICE CONNECTIONS (Continued)

 - STEAM SUPPLY: 3/4" IPS 5-30 psi (34-205 kPa). Optional 5-45 psi (34-310 kPa). \*  
 - CONDENSATE RETURN: 1/2" IPS

### DIMENSIONS

MODEL	CAPACITY		A	B	C	D	E	F(2")	F(3")	G(2")	G(3")	H	J	K
DP-20	20 gallons	inches	21	18	37	22.75	16	12.75	14	17	16.5	25.88	59.75	16.88
	76 litres	mm	533	457	940	578	406	324	356	432	419	657	1518	429
DP-30	30 gallons	inches	24	20	37	25.88	17.5	13.5	15.25	15	14.5	26.38	62.88	16.88
	114 litres	mm	610	508	940	657	445	343	387	381	368	670	1597	429
DP-40	40 gallons	inches	26	22.5	37	27.88	18.5	14.25	16.5	12.5	12	23.88	64.88	16.88
	152 litres	mm	660	572	940	708	470	362	419	318	305	606	1648	429
DP-60	60 gallons	inches	29.5	26	40.5	31.38	17.75	15.5	17.25	12.5	12	24.69	72.88	16.88
	227 litres	mm	749	660	1029	822	451	394	438	318	305	627	1851	429
DP-80	80 gallons	inches	33	28	42.5	34.75	19.5	17.5	19.25	10.5	10	23.88	77.25	19.63
	303 litres	mm	838	711	1080	883	495	445	489	267	254	606	1962	498
DP-100	100 gallons	inches	35.5	30	44.5	37.25	20.75	17	19.25	12.5	12	26.63	81.75	19.63
	379 litres	mm	902	762	1130	946	527	432	489	318	305	676	2076	498

\* Pressure reducing valve is required if incoming pressure exceeds 50 PSI (345 kPa).

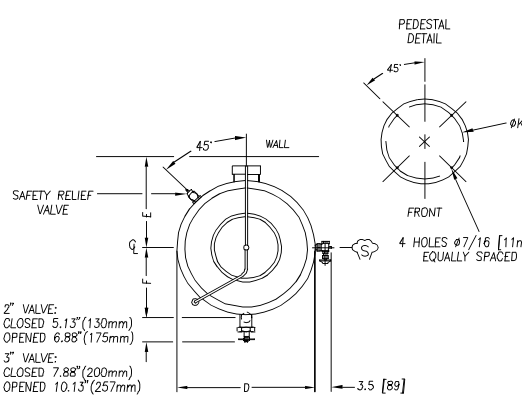

SAFETY RELIEF VALVE

45° WALL

PEDESTAL DETAIL

FRONT

4 HOLES  $\phi 7/16$  [11mm] EQUALLY SPACED

3.5 [89]

2" VALVE:  
CLOSED 5.13" (130mm)  
OPENED 6.88" (175mm)

3" VALVE:  
CLOSED 7.88" (200mm)  
OPENED 10.13" (257mm)

OPTIONAL FAUCET  
ALLOW DIMENSION "D"  
ADDITIONAL 6" [152mm]

MODEL	SHIPPING WT.	SPRING ASSIST HINGES MIN. CLEARANCE	
DP-20	155 lbs. [70 kg]	SIDES	3 [76mm]
DP-30	180 lbs. [82 kg]		
DP-40	190 lbs. [86 kg]		
DP-60	265 lbs. [120 kg]		
DP-80	308 lbs. [140 kg]		
DP-100	360 lbs. [163 kg]	BACK	0.50 [13mm]

YOKE TYPE HINGES MIN. CLEARANCE		
MODEL	SIDES	BACK
DP-20/30/40/60	3 [76mm]	5 [127mm]
DP-80/100	3 [76mm]	6 [152mm]

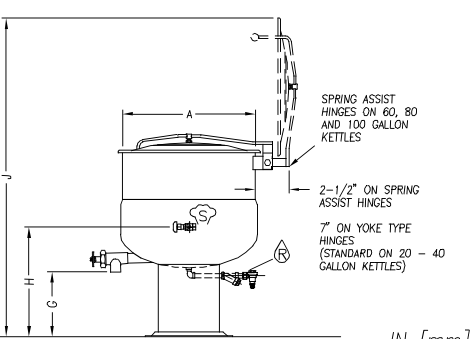

SPRING ASSIST HINGES ON 60, 80 AND 100 GALLON KETTLES

2-1/2" ON SPRING ASSIST HINGES

7" ON YOKE TYPE HINGES (STANDARD ON 20 - 40 GALLON KETTLES)

IN [mm]

2618R3

*As continued product improvement is a policy of Crown, specifications are subject to change without notice.*

INSTALLATION AND OPERATION MANUAL - DIRECT STEAM STATIONARY KETTLES,  
MODELS DL-20, 30, 40, 60, 80, 100 GALLON, DP-20, 30, 40, 60, 80, 100 GALLON

## 2.0 INSTALLATION INSTRUCTIONS

1. Select a location to provide drainage directly below the tangent Draw-off Valve.
2. Mark hole locations through flanged adjustable feet on DL models and through pedestal base on DP models. Remove kettle.
3. On hole locations marked, drill holes and insert expansion shields to accommodate 5/16" size lag bolts.
4. Reposition kettle. On DL models level kettle by making necessary adjustment on flanged foot.
5. Bolt down kettle and seal with Silastic or other equivalent sealing compound. Sealant must be applied not only to bolt heads but also around flanges or pedestal base making contact with floor surface to fulfill NSF requirements.
6. Install a steam control valve at a convenient location near kettle on the incoming steam line (3/4" size pipe).
7. Connect steam line to the kettle, making sure there is a steam control valve strainer fairly convenient to the kettle.
8. Connect kettle condensate return line to a drain or to a boiler return line. Each kettle return line must have a suitable steam trap. Boiler return lines must have a check valve.
9. Safety relief valve on kettle must not be plugged as it is set to relieve excess pressure in the kettle.
10. If incoming steam pressure is greater than kettle maximum operating pressure then a pressure reducing valve must be installed in the line.
11. If large amounts of water accumulate in the steam line it will be necessary to install one or more ball float traps in the line to eliminate the water.
12. A steam line pressure gauge is also recommended to determine the actual amount of steam coming to the kettle.
13. Check for proper operation.

INSTALLATION AND OPERATION MANUAL - DIRECT STEAM STATIONARY KETTLES,  
MODELS DL-20, 30, 40, 60, 80, 100 GALLON, DP-20, 30, 40, 60, 80, 100 GALLON

### **3.0 INTRODUCTION**

#### **DESCRIPTION**

All Crown direct connected steam jacketed kettles pertaining to this manual are direct steam operated pressure vessels of a double-wall stainless steel construction forming a steam chamber (jacket) enveloping the lower two thirds of the kettle bowl surface. All kettles are stationary, floor mounted in fixed positions either on legs with adjustable flanged feet (DL models) or pedestal (DP models).

#### **CAPACITIES**

All models are suffixed with either - 20, - 30, - 40, - 60, - 80 or -100 to indicate the capacity of that kettle in US gallons. Thus a DL - 40 is a two thirds jacketed direct steam kettle mounted on legs with a capacity of 40 gallons (US).

#### **FUNCTIONING MODE**

Crown direct connected steam jacketed kettles consist of a stainless steel bowl and a stainless steel jacket which envelopes two thirds of the lower surface of the bowl thus forming a sealed pressure vessel (chamber) into which steam is introduced by means of a manual control valve.

The kettle bowl is the container for the food product which ideally should be of a liquid or semi-liquid consistency to achieve complete contact with the bowl surface and thus fully absorb the heat transmitted through that surface.

The temperatures required for the cooking process to function adequately must be greater than the boiling point of the liquid food product, viz. water. Further, the greater the steam pressure used, the higher the temperature and consequently the quicker the cooking process. For example, steam pressurized at 30 p.s.i. attains a temperature of 274 degrees Fahrenheit (135 degrees Celsius).

INSTALLATION AND OPERATION MANUAL - DIRECT STEAM STATIONARY KETTLES,  
MODELS DL-20, 30, 40, 60, 80, 100 GALLON, DP-20, 30, 40, 60, 80, 100 GALLON

#### 4.0 OPERATING INSTRUCTIONS



**CAUTION: The appliance and its parts are hot. Use care when operating, cleaning and servicing the appliance.**

#### OPERATING PROCEDURE

1. Ensure that draw-off valve is closed.
2. Fill kettle with product to desired level.
3. Slowly turn the steam control valve ON to full open position (counter clockwise).
4. The water or food should boil 2 - 3 gallons per minute. If it does not then incoming pressure and piping should be checked to determine that it is adequate to operate the kettle efficiently.
5. Regulate steam control valve depending on type of food being prepared.
6. When food is cooked, turn off steam, remove food and clean kettle immediately to prevent residue from drying on kettle bowl surface.



## 5.0 CLEANING PROCEDURES

Your kettle should be cleaned immediately after each use.

1. Ensure that steam supply is OFF.
2. Pre-rinse inside of kettle thoroughly and drain to remove any food particles.
3. Using a nylon brush, clean kettle with a mild detergent and warm water rinse. Never use steel wool or scouring powder as it will scratch stainless steel.
4. Open the tangent draw-off valve to allow soap and water solution to drain. Rinse with clean water.



**WARNING:** If you are cleaning a valve that is assembled to a kettle be sure the kettle is completely empty of any product.

5. By hand, turn the large hex nut counterclockwise on draw off valve until it is completely disengaged from thread. Grasp knob to valve and slowly pull out valve stem and disc. Do not allow disc to come in contact with hard surfaces since damage to disc may occur and result in valve leakage. Wash the valve stem, disc and handle. Insert nylon brush with detergent into interior of valve body and tangent draw-off tube and brush vigorously.
6. Replace valve stem assembly and engage hex nut fully by hand. Flush kettle with clean warm water.
7. Leave valve open when kettle is not in use.



**CAUTION:** Do not use cleaning agents that are corrosive.

INSTALLATION AND OPERATION MANUAL - DIRECT STEAM STATIONARY KETTLES,  
MODELS DL-20, 30, 40, 60, 80, 100 GALLON, DP-20, 30, 40, 60, 80, 100 GALLON

**5.0 CLEANING PROCEDURES** (Continued)

Use of cleaning agents that contain chloride, acids or salts are corrosive and may cause pitting and corrosion when used over a period of time; this will reduce the life of the appliance.

Should pitting or corrosion occur this is not covered by warranty.

Follow the recommended cleaning instructions. Use a mild detergent, warm water and rinse thoroughly.

INSTALLATION AND OPERATION MANUAL - DIRECT STEAM STATIONARY KETTLES,  
MODELS DL-20, 30, 40, 60, 80, 100 GALLON, DP-20, 30, 40, 60, 80, 100 GALLON

## **6.0 TROUBLESHOOTING MAINTENANCE**

### **PREVENTIVE MAINTENANCE**

No preventive maintenance is required other than adhering to the Cleaning Procedure instructions.

### **DRAW-OFF VALVE LEAKS**

If a leak occurs through the valve stem, replace the "O" ring.

If the leak can be attributed to faulty sealing occurring between the stem disc and valve seat, then this problem may be corrected by cleaning off the dried-on food residue with extremely fine emery cloth. If the vulcanized rubber stem piece has been damaged, it must be replaced.

**NOTICE: Draw-off valve has a vulcanized rubber coated stem for better sealing. Do not over tighten. This may cause the rubber to pull away from stem and permanently damage it. This is not covered under warranty.**

### **EXTREMELY SLOW COOKING TIME**

If the cooking time is abnormally slow, this may be due to insufficient steam pressure and/or volume. First determine that pressure on incoming steam line at kettle is within 5 p.s.i. of rated kettle pressure. Note that pressures approaching the rated kettle pressure are liable to set off the safety relief valve. If required pressure is available to kettle, then possibly volume of steam is not sufficient. Minimum 3/4" pipe size is required to the kettle but if the steam generating source is at a great distance from the kettle, larger supply pipe will be required. Finally, the core of the steam supply pipe may have debris or scalants that impede steam flow and will require disassembly and inspection.

INSTALLATION AND OPERATION MANUAL - DIRECT STEAM STATIONARY KETTLES,  
MODELS DL-20, 30, 40, 60, 80, 100 GALLON, DP-20, 30, 40, 60, 80, 100 GALLON

## **6.0 TROUBLESHOOTING MAINTENANCE**

### **VENTING**

It is recommended that the "optional" steam trap assembly be installed. This should be plumbed to the exit end of the kettle. The thermostatic trap is a mechanical device that closes on high temperature and opens when the temperature drops, allowing the water which formed from condensate to exhaust but retain the steam under pressure.

The temperatures required for the cooking process to function adequately must be greater than the boiling point of the liquid food product, that is, water. The greater the steam pressure used, the higher the temperature and the quicker the cooking process. For example, steam pressurized at 30 p.s.i. reaches a temperature of 274 degrees Fahrenheit (135 degrees Celsius).