



**The Industry Leader in Burnishing**  
Adamation Burnishers are in use in nearly every country of the world, and have been the standard of the industry for over 40 years.

## ABV-300 *formerly model #VM-288*

Vibratory Silverware Burnisher  
Rated capacity of 300 pcs. of flatware, 450 lbs. of media. Ideal for large restaurants, hotels, banquet facilities.

### STANDARD FEATURES

- **Acoustically-insulated Body**  
Full interior lining reduces noise levels produced by unit.
- **Open Top Vibrating Drum**  
Open top design speeds loading and unloading even while machine is in use. Vibrating motion creates continuous "slide zone" that gently rolls away scratches.
- **Stainless Steel Construction**  
For long life and easy maintenance in any environment.
- **Polishes Flatware and Holloware**  
Eliminates hand polishing of odd-shaped pieces. Large 22 x 11 x 18.5" drum size permits polishing of oversize items.
- **Hardened Steel Polishing Media**  
Includes 450 lbs. of burnishing balls and ?? gal. burnishing liquid.
- **Built-in Water Recirculation**  
Spigot supplies burnishing solution to top of media for improved circulation and polishing performance.

### OPTIONAL EQUIPMENT

- **Locking Cover**  
Allows unattended use without fear of theft.
- **Media Saver**  
Funnel-shaped extension minimizes ball loss during unloading.



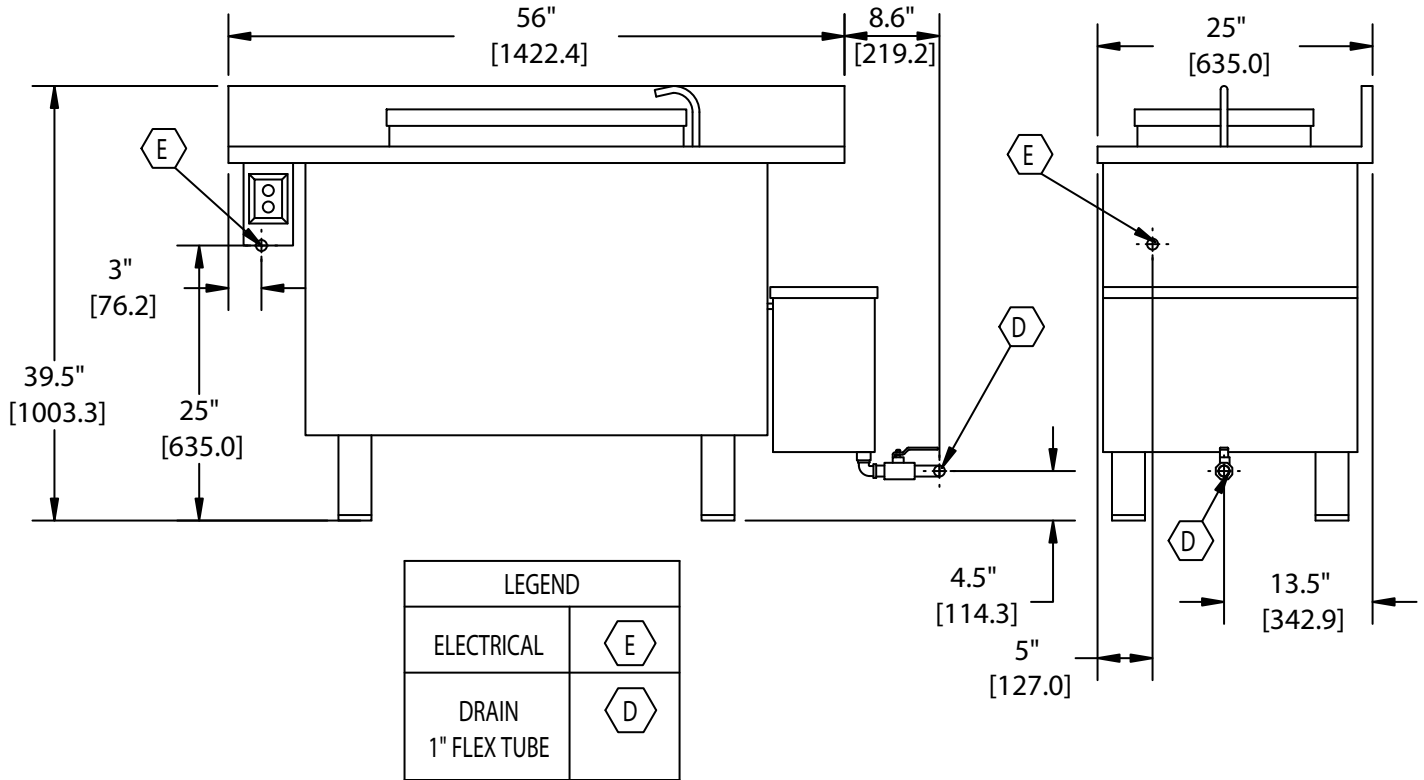

### Specifications

Flatware Capacity	Media Capacity	Burnishing Compound	Crate Size	Ship Weight
300 pcs.	450 lbs.	1 pkg.	63 cu. ft.	approx. 1410 lbs.

### Electrical Requirements

Current (V/Ph/Cyc)	Amps
208 / 3 / 60	8.3
220 / 3 / 60	8.4
440 / 3 / 60	4.4
480 / 3 / 60	4.1
380 / 3 / 50	4.9
415 / 3 / 50	4.3
460 / 3 / 50	3.9