

Alphabetical Index

DESCRIPTION	PAGE	DESCRIPTION	PAGE
B		H	
BALL BEARING ASSEMBLIES	G30	CONCEALED CABINET HINGES	G12
BEARINGS	G27 - G30	CONCEALED PIVOT HINGES	G12
BOLT, SECURITY	G14	LATCH HINGES	G12
BRACKETS, HANDLE	G5	BUTT HINGES	G12
BUMPERS	G26	PIVOT HINGES	G12
		LIFT-OFF HINGES	G11
C		K	
CASH BOXES, CASH DRAWERS	G24	KNOBS	G5
CATCHES	G15, G16		
CARDHOLDER-PULL	G9		
CONCAVE BEARINGS	G29	L	
		LATCHES	G8 - G11
		LOCKS	G13 - G14
D		O	
DOOR GUIDES	G31	OVERHEAD TRACK COMPONENTS	G31
DOOR HANDLES	G2		
DOOR STOP	G31		
DRAWER ASSEMBLY	G23	P	
DRAWER BOTTOM PLATES	G23	PADDLE LATCHES	G8
DRAWER BRACKETS	G25	PULL/PUSH PLATES	G2
DRAWER FRONTS	G25	PULLS	G6, G7, G9
DRAWER PANS	G22	PULLEY	G30
DRAWER SLIDES	G17 - G21		
DRAWER SPACERS	G23	R	
		RUBBER TIRE BEARINGS	G29
F		S	
FLAT BEARINGS	G28	SHEAVES	G31
		SLIDING DOOR COMPONENTS	G31
G		STUD, FEMALE	G7
GRAB BARS	G3	SUPPORTS, HANDLE	G5
GROMMETS	G26		
GUIDE PINS	G31	T	
		THUMBSCREW FASTENER	G6
H		W	
HANDLE BRACKETS	G5	WHEELS	G30
HANDLES	G2, G4 - G6, G9		
HAND RAILS	G3		
HASP & STAPLE	G9		
HINGES	G10 - G12		
CONTINUOUS HINGES	G10		

All photographs and illustrations are considered to be a representation of the actual item. In some cases there may be slight variations. This catalog, copy, part numbers and unique method of illustrating products is copyrighted by Component Hardware Group, Inc. All rights reserved. No portion of this catalog may be reproduced in any form or by any means in whole or in part, without the written consent of Component Hardware.

Component Hardware Group reserves the right to make any and all changes and to discontinue any of its products without notice.

Not responsible for typographical errors.

*May not be identical to competitors' products.

Component Hardware Group is a proud member of the following organizations



Products shown in this catalog may be listed and/or certified by one or more of the following regulatory agencies and will be designated by the following marks



Door Handles & Pull/Push Plates

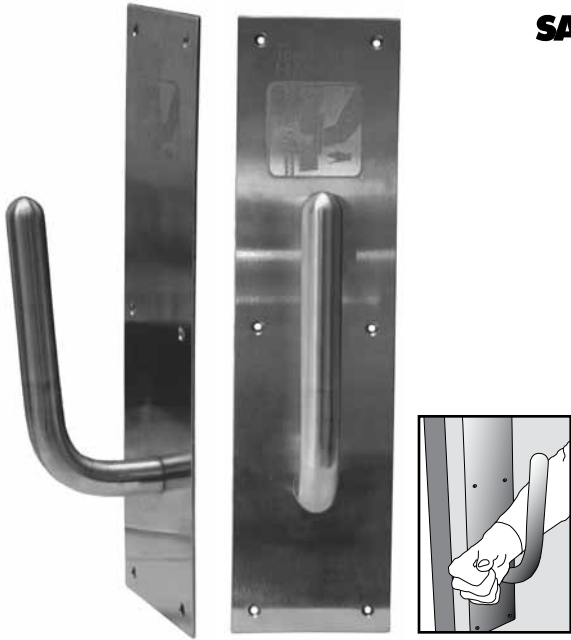

SANIGRASP™ DOOR HANDLE

- HEAVY DUTY CONSTRUCTION MOUNTING HARDWARE INCLUDED
- FULL 1" ANGLED TUBULAR PULL FOR OPENING EASE WITH THE FOREARM
 - HOLE PATTERNS TO MATCH MOST STANDARD DOOR PUSH-PULL PLATES MAKE RETRO-FIT EASY
- PROVIDED WITH SANIGUARD® ANTIMICROBIAL PRODUCT PROTECTION
 - ELIMINATES THE NEED TO USE YOUR HAND TO OPEN RESTROOM DOOR AFTER WASHING YOUR HANDS
 - ADA AND ABA COMPLIANT

MODEL NO. SG-101

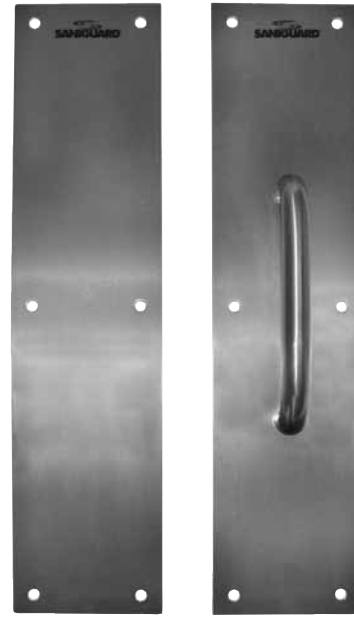
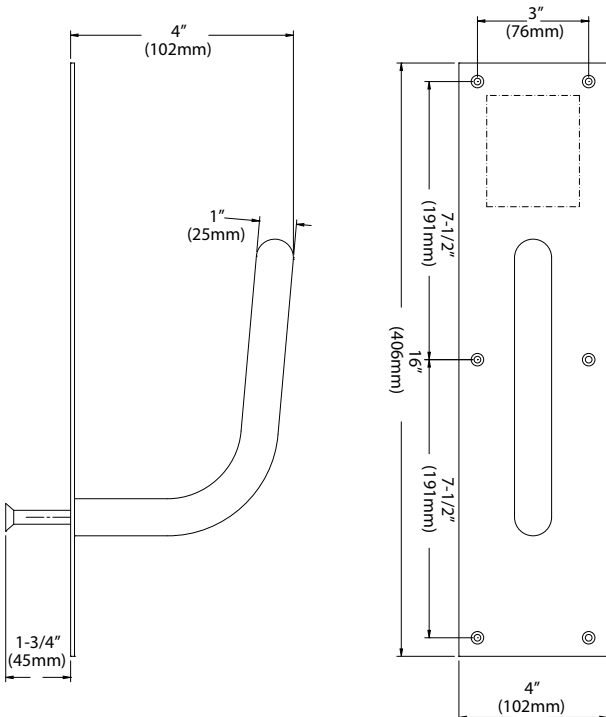

PULL/PUSH PLATES

- ALL STAINLESS STEEL CONSTRUCTION RETRO-FITS TO MOST COMMON PUSH/PULL PLATE HOLE-PATTERNS
- SANIGUARD® TREATMENT INHIBITS THE GROWTH OF BACTERIA, MOLDS AND FUNGI, WHICH CAN CAUSE ODORS, STAINING AND PRODUCT DETERIORATION AND ELIMINATES FINGERPRINTS
 - SANIGUARD® PRODUCT PROTECTION WILL LAST FOR THE USEFUL LIFE OF THE PRODUCT

MODEL NO. P75-1000-Q

MODEL NO. P75-4000

MODEL NO. P75-5000

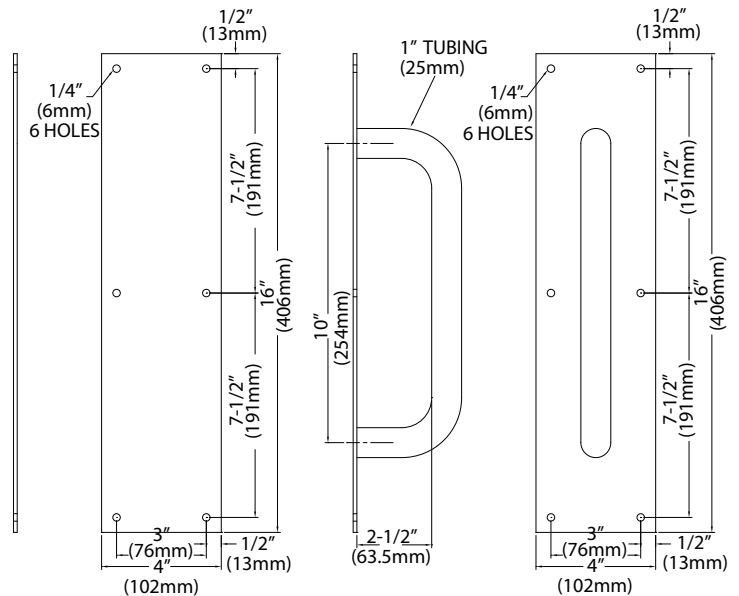

NOTE: SANIGUARD® PRODUCT PROTECTION IS DESIGNED TO KEEP THE PRODUCT FRESHER AND CLEANER BETWEEN NORMAL CLEANING ROUTINES. IT IS NOT A DISINFECTANT AND WILL NOT PROTECT USERS OR OTHERS AGAINST FOOD-BORNE ILLNESS OR DISEASE. ALWAYS USE GOOD HYGIENE AND CLEANING PRACTICES.

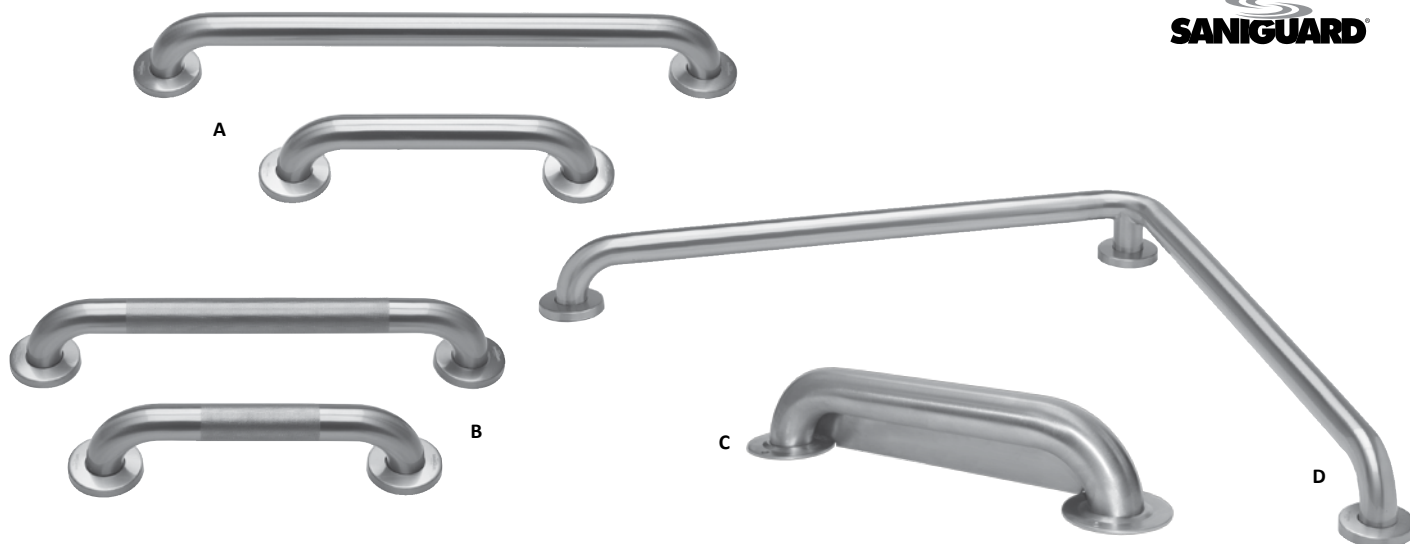

GRAB BARS AND HAND RAILS

REF. A SMOOTH FINISH GRAB BAR		REF. B KNURLED FINISH GRAB BAR		REF. C PRISON ANTI-LIGATURE GRAB BAR	
MODEL NO.	DIMENSION	MODEL NO.	DIMENSION	MODEL NO.	DIMENSION
GBS15-1112-Q	12" (305mm)	GBS15-4112-Q	12" (305mm)	GBS15-1112-QP	12" (305mm)
GBS15-1116-Q	16" (406mm)	GBS15-4116-Q	16" (406mm)	GBS15-1116-QP	16" (406mm)
GBS15-1118-Q	18" (457mm)	GBS15-4118-Q	18" (457mm)	GBS15-1118-QP	18" (457mm)
GBS15-1124-Q	24" (610mm)	GBS15-4124-Q	24" (610mm)	GBS15-1124-QP	24" (610mm)
GBS15-1130-Q	30" (762mm)	GBS15-4130-Q	30" (762mm)	GBS15-1130-QP	30" (762mm)
GBS15-1132-Q	32" (813mm)	GBS15-4132-Q	32" (813mm)	GBS15-1132-QP	32" (813mm)
GBS15-1136-Q	36" (914mm)	GBS15-4136-Q	36" (914mm)	GBS15-1136-QP	36" (914mm)
GBS15-1142-Q	42" (1067mm)	GBS15-4142-Q	42" (1067mm)	GBS15-1142-QP	42" (1067mm)
GBS15-1148-Q	48" (1219mm)	GBS15-4148-Q	48" (1219mm)	GBS15-1148-QP	48" (1219mm)

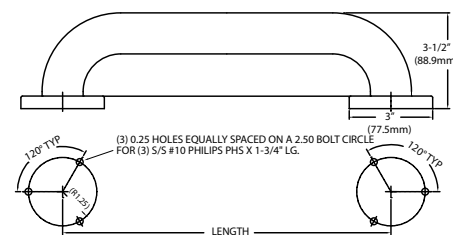
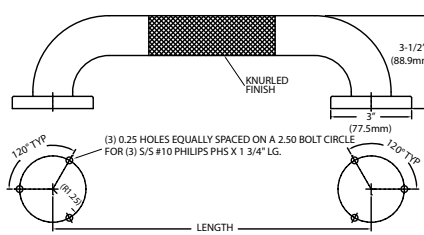
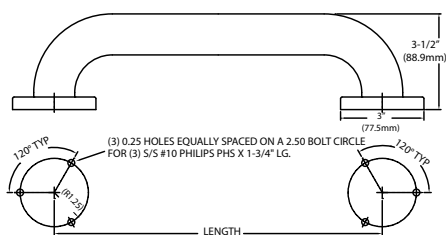

REF. D

SMOOTH L-SHAPED GRAB BAR

MODEL NO.	DIMENSION
GBS15-113030Q	30" x 30" (762mm x 762mm)
-	40" x 30" (1017mm x 762mm)

KNURLED L-SHAPED GRAB BAR

MODEL NO.	DIMENSION
GBS15-413030Q	30" x 30" (762mm x 762mm)
GBS15-414030Q	40" x 30" (1017mm x 762mm)

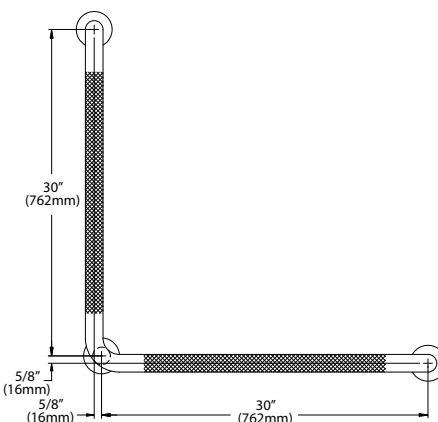

STAINLESS STEEL, 1-1/2" DIAMETER GRAB BARS. AVAILABLE IN SMOOTH OR KNURLED FINISH, COMPLETE WITH CONCEALED MOUNTING FLANGE AND PRESS-ON FLANGE COVER. ALL GRAB BARS ARE PERMANENTLY COATED WITH SANIGUARD® TREATMENT.

NOTE: SANIGUARD® PRODUCT PROTECTION IS DESIGNED TO KEEP THE PRODUCT FRESHER AND CLEANER BETWEEN NORMAL CLEANING ROUTINES. IT IS NOT A DISINFECTANT AND WILL NOT PROTECT USERS OR OTHERS AGAINST FOOD-BORNE ILLNESS OR DISEASE. ALWAYS USE GOOD HYGIENE AND CLEANING PRACTICES.

Handles

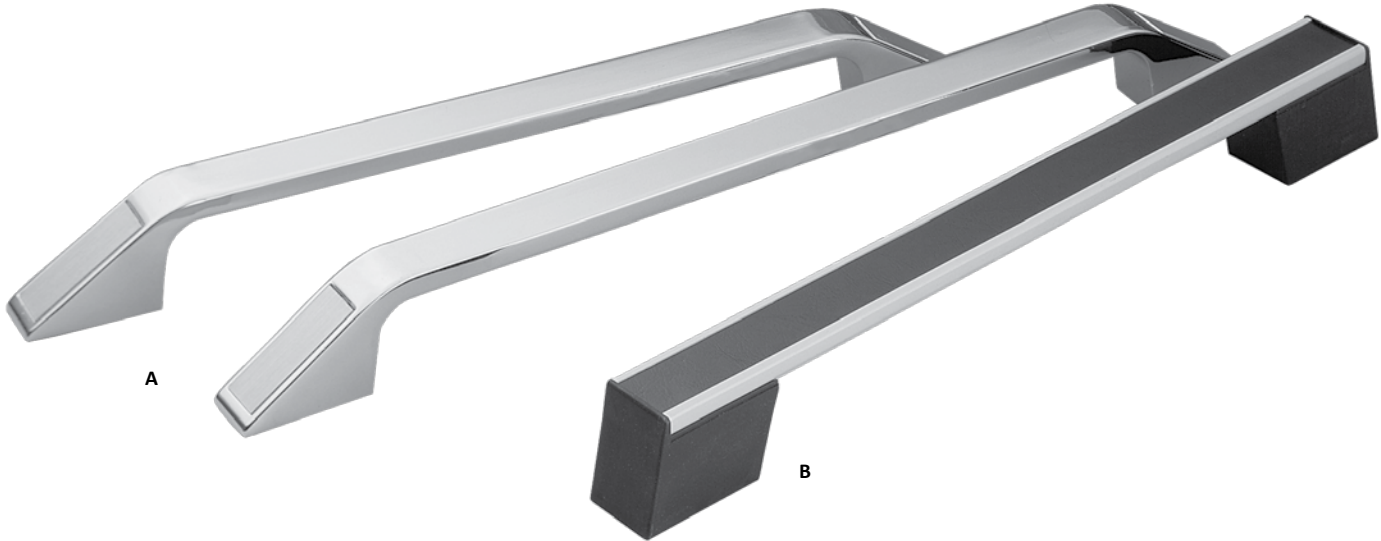

HANDLES

REF. A



SCULPTURED HANDLES FEATURING...

- SOLID METAL CASTING • POLISHED CHROME FINISH
- FRONT OR REAR FASTENING • TWO LENGTHS AVAILABLE

MODEL NO.	O.A. LENGTH	"A" DIM.	"B" DIM.
P48-1010	14-5/8" (371mm)	13-7/16" (340mm)	12-7/16" (316mm)
P48-1012	12-13/16" (325mm)	11-5/8" (295mm)	10-5/8" (270mm)

NOTES: "A" DIMENSION REPRESENTS HOLE CENTERS FOR FRONT MOUNTING #10 SCREWS. "B" DIMENSION REPRESENTS THREADED HOLE CENTERS TO RECEIVE 1/4-20 SCREWS FOR REAR MOUNTING. DECORATIVE TRIM INSERTS ARE SUPPLIED TO CONCEAL FRONT MOUNTING SCREWS. EXTRA TRIM INSERTS ARE AVAILABLE AND MAY BE ORDERED AS **MODEL NO. P48-X002**.

REF. B

DECORATIVE HANDLES FEATURING...

- DUAL MOUNTING...FRONT OR REAR • TWO STANDARD LENGTHS AVAILABLE
- HEAT RESISTANT • HEAVY DUTY CONSTRUCTION
- ANODIZED ALUMINUM HANDLE WITH NYLON SUPPORTS

MODEL NO.	O.A. LENGTH	O.C. MOUNTING DIM.
P49-1500-6	7-11/16" (195mm)	6" (152mm)
P49-1500	12-1/4" (311mm)	10-5/8" (270mm)

NOTES: PRE-ASSEMBLED HANDLES WILL ACCEPT SCREWS FOR FRONT MOUNTING. INTERNAL BRASS BUSHINGS ACCEPT STANDARD 1/4-20 MACHINE SCREWS FOR REAR FASTENING. A PRESSURE SENSITIVE BLACK VINYL INSERT CONCEALS SCREW HOLES. OTHER LENGTHS AVAILABLE UPON APPLICATION ON QUANTITY ORDERS.

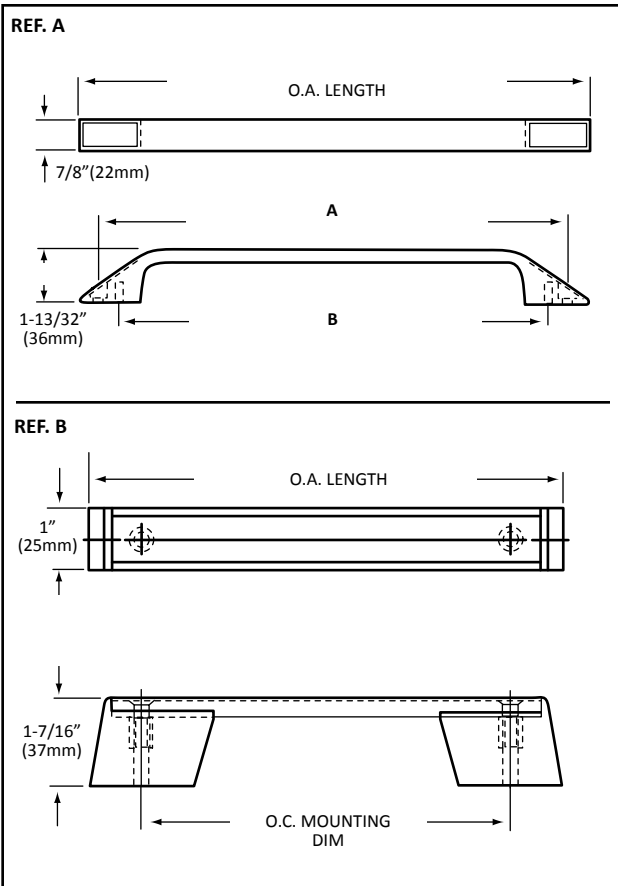

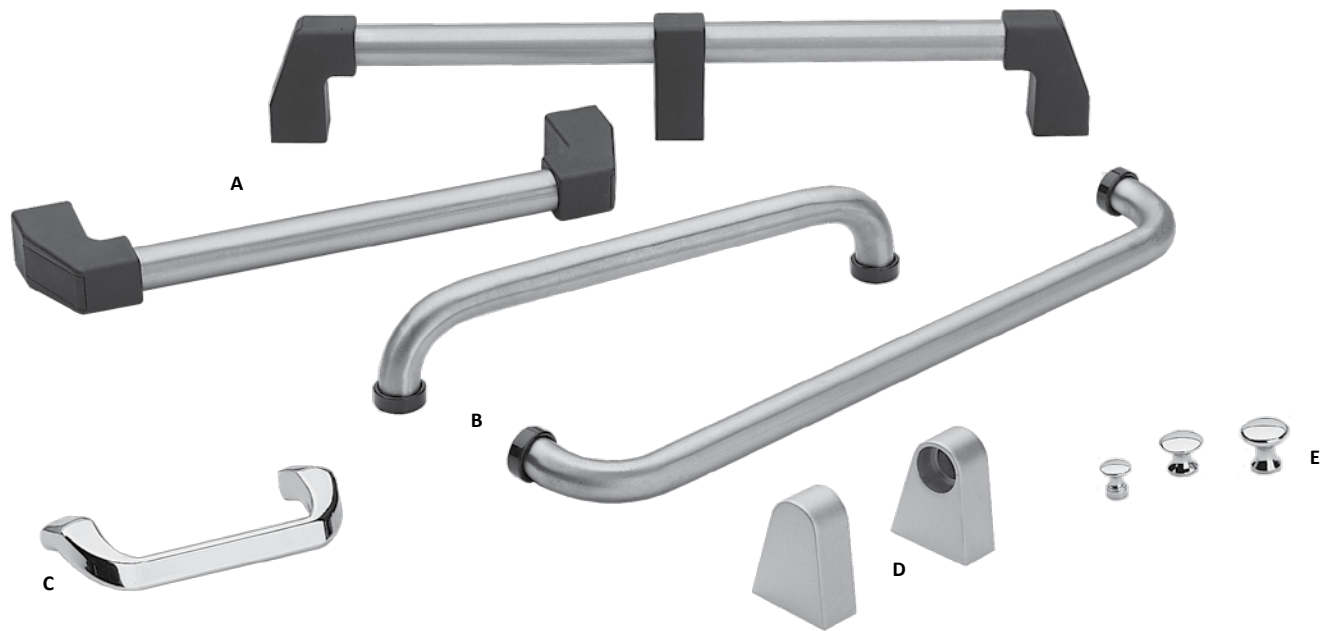

HANDLES & KNOBS

REF. A HANDLE BRACKETS HEAVY-DUTY NYLON

FIBERGLASS REINFORCED END BRACKETS (PR.)
AND CENTER SUPPORT BRACKET (EA.)

IDEAL FOR MOBILE CARTS.
CONCEALED MOUNTING FEATURE. FRONT OR REAR MOUNT.
TEMPERATURE RANGE TO 300°F (149°C).

MODEL NO. P49-2100
END BRACKET (PAIR)

MODEL NO. P49-2200
CENTER SUPPORT
BRACKET (EACH)

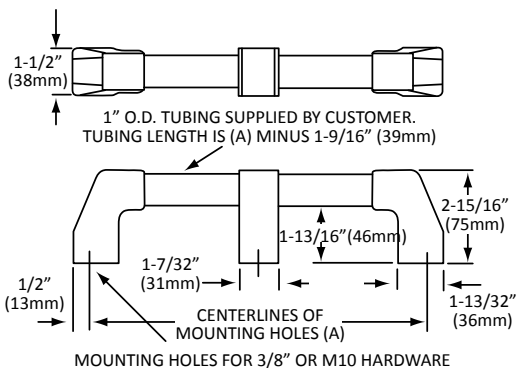

REF. B HEAVY-DUTY TUBULAR HANDLES STAINLESS STEEL, SATIN FINISH

MODEL NO. P47-1012
12-7/8" (327mm) O.A. 12" (305mm) O.C.

MODEL NO. P47-1018
18-7/8" (479mm) O.A. 18" (457mm) O.C.

MATERIAL: 7/8" (22mm)
O.D. STAINLESS STEEL FORMED TUBING

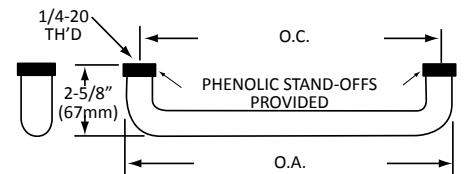

REF. C OFFSET HANDLE CHROME PLATED **MODEL NO. P40-1010**

MATERIAL: CHROME PLATED DIE CAST METAL

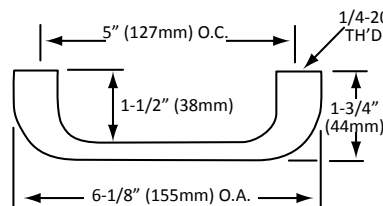

REF. D

HANDLE SUPPORTS ALUMINUM FOR 1" (25mm) O.D. TUBING

EACH SUPPORT IS TAPPED
TO RECEIVE (2) 1/4-20 SCREWS

MODEL NO. P49-1010 (ONE PAIR)

MATERIAL: DIE CAST ALUMINUM
WITH SATIN TEXTURED FINISH

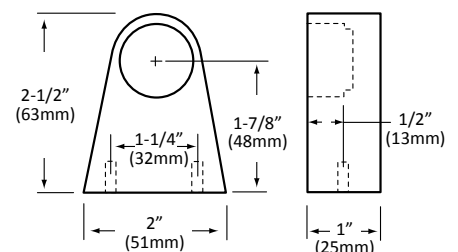

REF. E

CHROME PLATED BRASS KNOBS

ALL KNOBS TAPPED TO
RECEIVE #8-32 SCREWS.

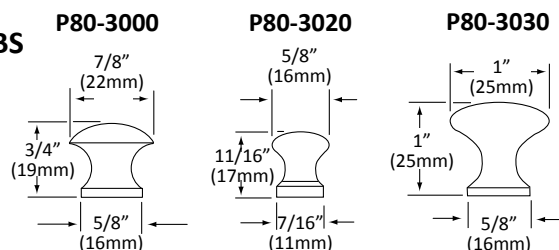

Pulls

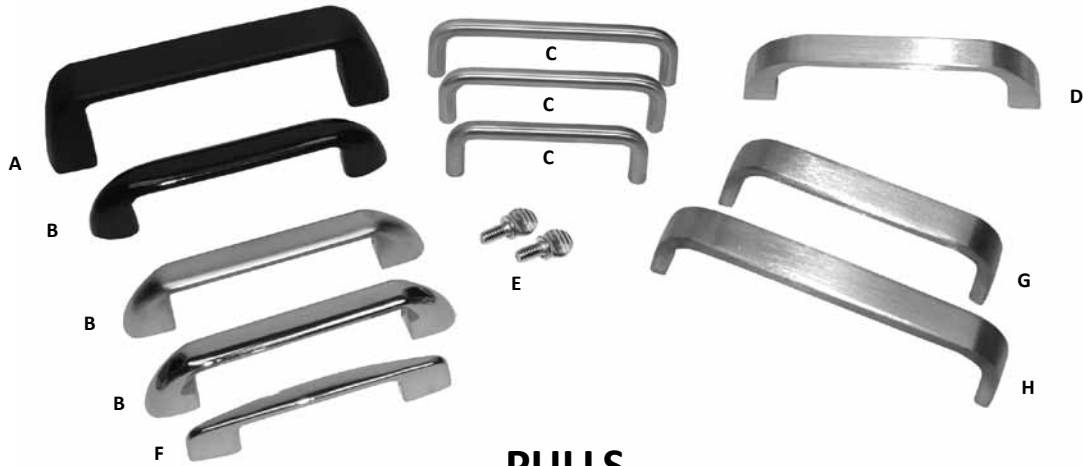

PULLS

REF. A
HANDLE
BLACK NYLON FIBERGLASS REINFORCED WITH SOLID BRASS TAPPED INSERTS

IDEAL FOR HEATED CABINETS.
RATED TO 300°F (149°C TEMPERATURE).
FULL 1-3/8" GRIP CLEARANCE

MODEL NO. P53-1012

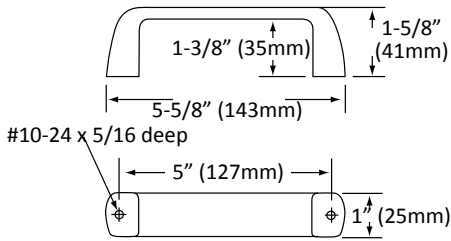

REF. B
PULLS
DIE CAST OR NYLON

MODEL NO.	MATERIAL	FINISH
P50-1010	DIE CAST	POLISHED CHROME
P50-1011	DIE CAST	BUFFED SATIN
P52-1010*	NYLON	GLOSS BLACK

*FURNISHED WITH THREADED BRASS INSERTS

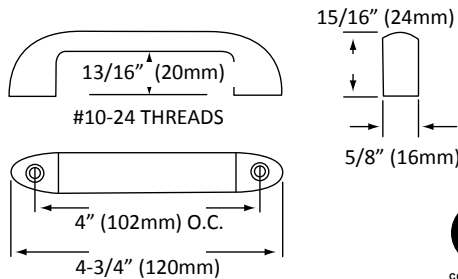

REF. C
WIRE PULLS
SATIN CHROME FINISH

MODEL NO.	"A"
P45-3000	3" (76mm)
P45-3500	3-1/2" (89mm)
P45-4000	4" (102mm)

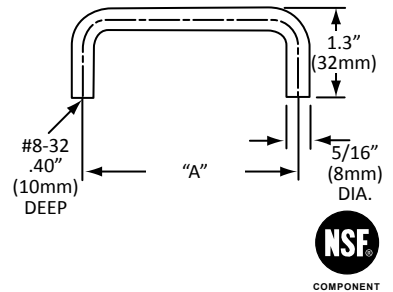

REF. D
PULLS
ALUMINUM ALLOY SATIN FINISH
MODEL NO. P44-1010

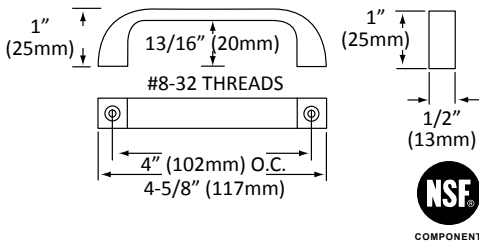

REF. E
THUMBSCREW FASTENER
STAINLESS STEEL
MODEL NO. P51-1024

USED TO MEET NSF REQUIREMENTS WHERE HANDLES & PULLS MUST BE FASTENED OR REMOVED WITHOUT THE USE OF TOOLS

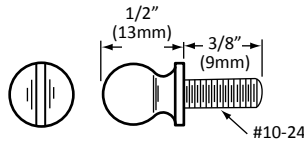

REF. F
PULLS
DIE CAST...CHROME PLATED
MODEL NO. P51-1010

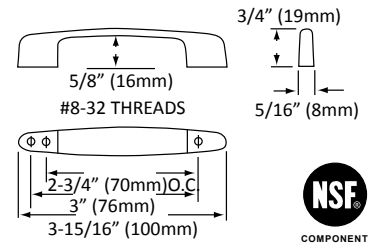

REF. G, H
BAR PULLS, STAINLESS STEEL...SATIN FINISH
MATERIAL: 1/4" (6mm) THICK SOLID STAINLESS STEEL



DWG. REF.	REF. I MODEL NO. P46-1010	REF. H MODEL NO. P46-1012
A	1" (25mm)	1" (25mm)
B	5" (127mm) O.C.	4" (102mm) O.C.
C	5-1/4" (133mm)	4-1/4" (108mm)
D	1-1/4" (32mm)	1-1/4" (32mm)
E	5/8" (16mm)	5/8" (16mm)

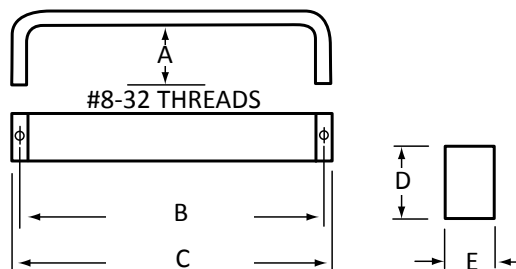

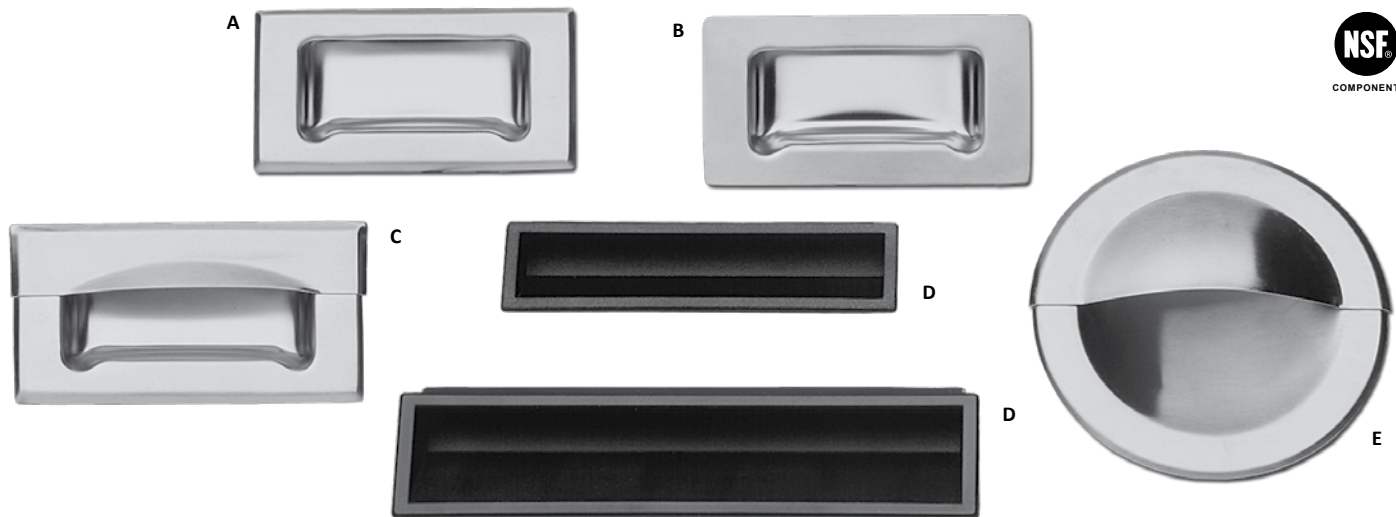

RECESSED PULLS

REF. A

DOOR PULL
STAINLESS STEEL
WITH FRAME BEVELED EDGE

MODEL NO. P62-1010
RETAINING LOCKNUTS PROVIDED

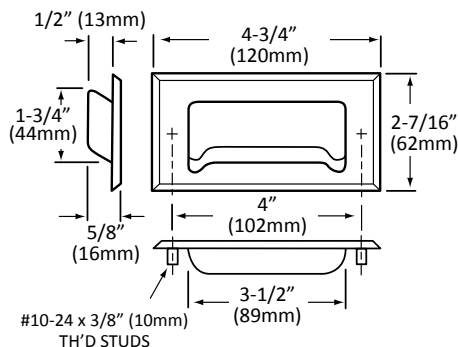

REF. B

DOOR PULL
STAINLESS STEEL
FLUSH TYPE FOR WELDING

MODEL NO. P62-1014

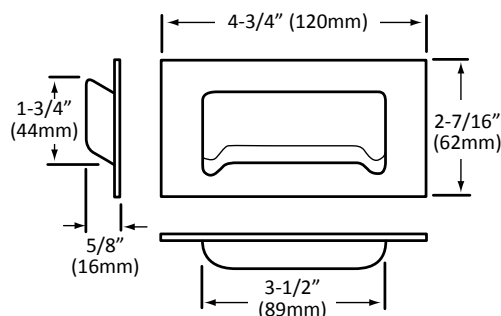

REF. C

DRAWER PULL
STAINLESS STEEL
FULL GRIP TYPE WITH
FRAME BEVELED EDGE

MODEL NO. P63-1012
RETAINING LOCKNUTS PROVIDED

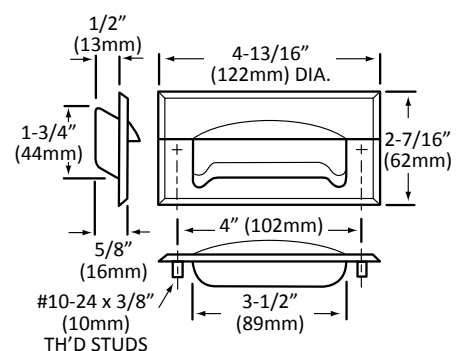

REF. D

RECESSED DOOR PULL

- BLACK ABS THERMOPLASTIC
- SHOCK RESISTANT • SNAP-IN STYLE

ONE PIECE CONSTRUCTION FOR FAST, EFFICIENT INSTALLATION

MODEL NO.	A	B	C	D	E	F
P73-1000	5" (127mm)	5-7/16" (138mm)	1" (25mm)	1-7/16" (37mm)	1-9/16" (40mm)	5/8" (16mm)
P73-2000	7" (178mm)	7-7/16" (189mm)	1-5/16" (33mm)	1-3/4" (44mm)	2-1/16" (52mm)	7/8" (22mm)

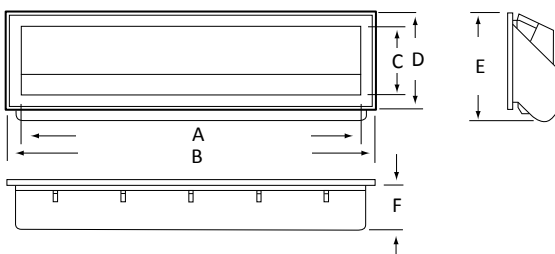

FEMALE STUD

CONVERTS MALE
STUD TO FEMALE

IDEAL FOR USE ON
WOOD CABINETS



#10-24 TH'D X 5/8"
(16mm) LG.

MODEL NO.
P50-5000

REF. E

ROUND PULL
STAINLESS STEEL
WITH BEVELED EDGE MOUNT

MODEL NO. P60-1010
RETAINING LOCKNUTS PROVIDED

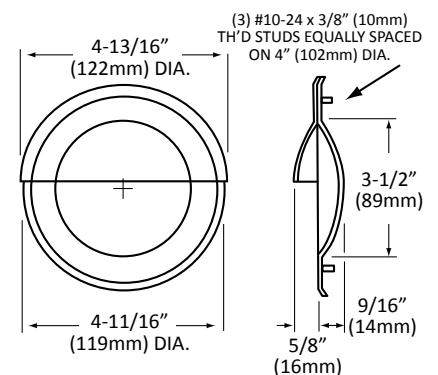

Heavy Duty Stainless Steel Slide & Paddle Latches

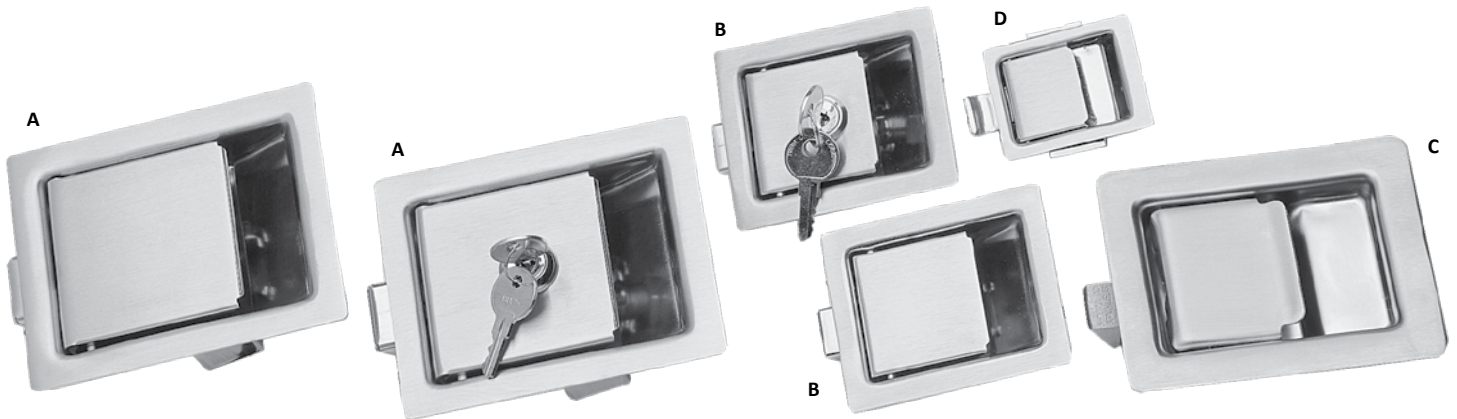

HEAVY- DUTY STAINLESS STEEL PADDLE LATCHES



- BRUSHED STAINLESS STEEL FINISH
- RUGGED ALL STAINLESS CONSTRUCTION
- ALLOWS FOR CLEAN, FLUSH MOUNTING
- CONVENIENT SIZE LATCHES OFFER A WIDE RANGE OF APPLICATION
 - ECONOMICALLY PRICED
- UNIQUE REAR MOUNTING BRACKET PROVIDES FAST INSTALLATION
- IDEAL FOR MOBILE CARTS AND ACCESS DOORS WHERE CONVENTIONAL SURFACE MOUNTED HARDWARE IS INAPPROPRIATE

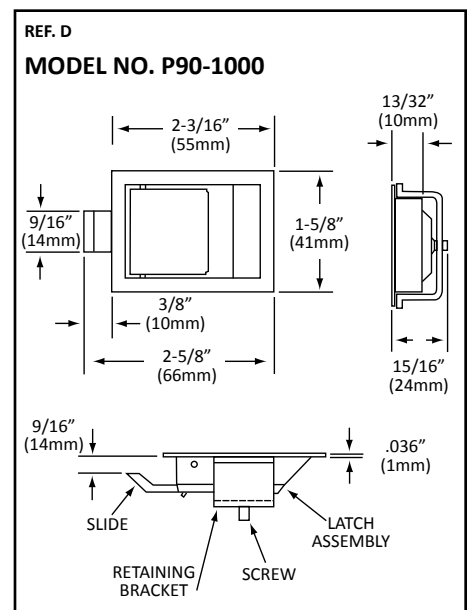
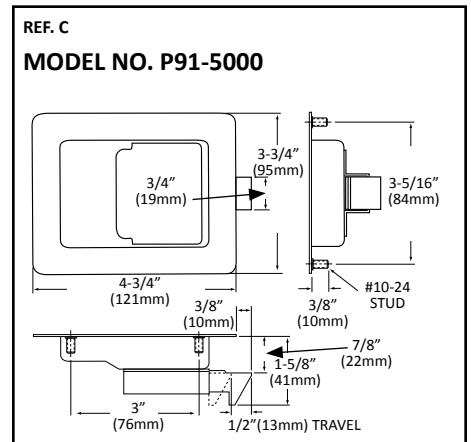
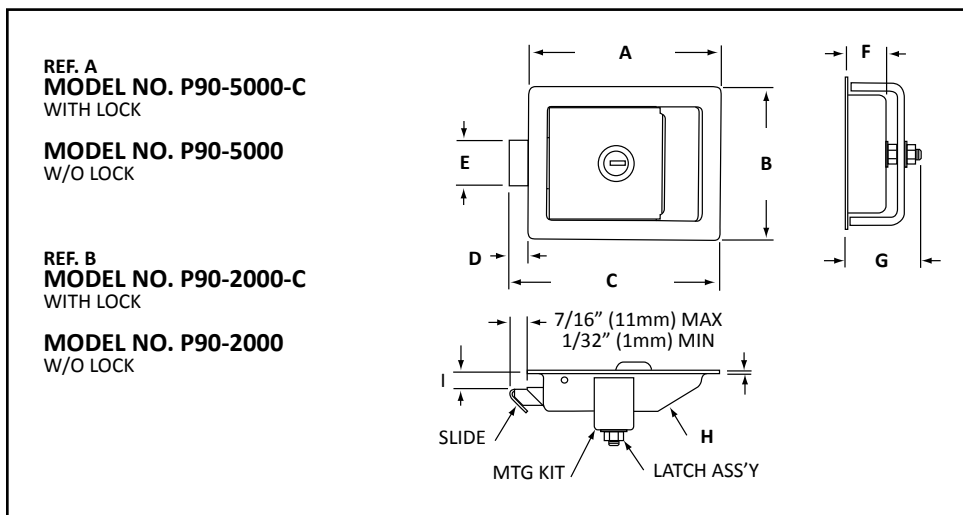

REF.	MODEL NO.	A	B	C	D	E	F	G	H	I
A	P90-5000	4-7/8"	3-7/8"	5-3/8"	1/2"	1-5/32"	1-1/32"	1-29/32"	.63"	7/16"
	P90-5000-C	(124mm)	(98mm)	(137mm)	(13mm)	(29mm)	(26mm)	(48mm)	(16mm)	(11mm)
B	P90-2000	3-5/16"	2-11/16"	3-5/8"	5/16"	3/4"	3/4"	1-13/32"	.048"	5/16"
	P90-2000-C	(84mm)	(68mm)	(92mm)	(8mm)	(19mm)	(19mm)	(36mm)	(2mm)	(11mm)

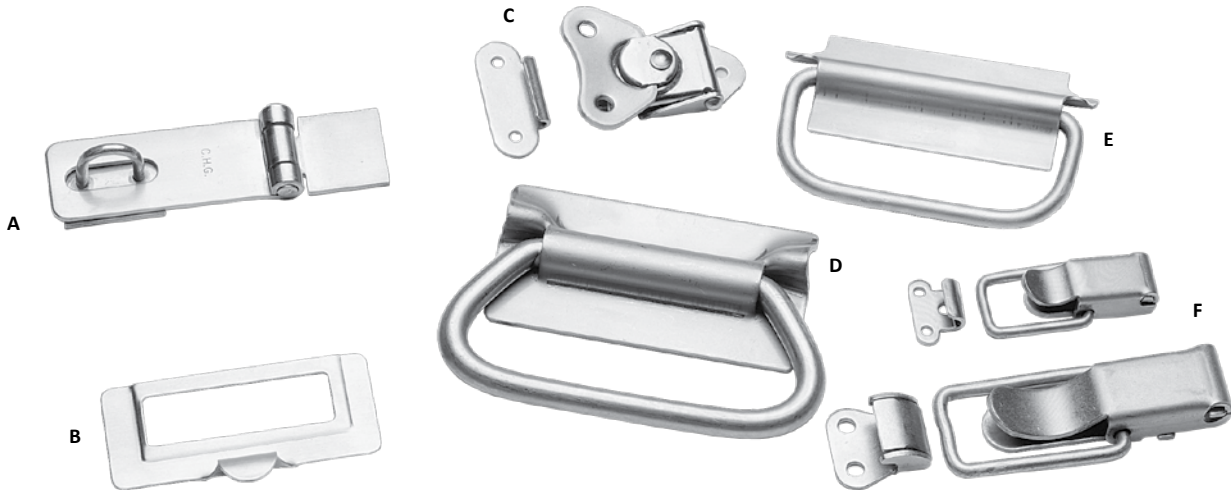

PULLS & CATCHES

REF. A

HASP & STAPLE, STAINLESS STEEL

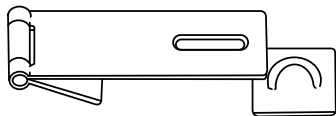

MODEL NO. M80-2500

2-1/2" x 1" x .072
(63mm x 25mm x 2mm)

REF. B

CARDHOLDER & PULL, STAINLESS STEEL

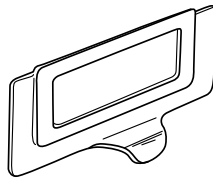

MODEL NO. P88-1010

OVERALL SIZE:
2-15/16" x 1-5/16" (74mm x 33mm)
CARD SIZE:
2-1/8" x 1-1/8" (54mm x 28mm)

REF. C

LINK-LOCKING LATCH, STAINLESS STEEL

MODEL NO. M11-8201
HEIGHT: 2-1/4" (57mm)
WIDTH: 1-7/16" (36mm)
PROFILE: 1/2" (12mm)
PULL DOWN PRESSURE: 90 lbs (41kg)
LOAD CAPACITY: 300 lbs (136kg)

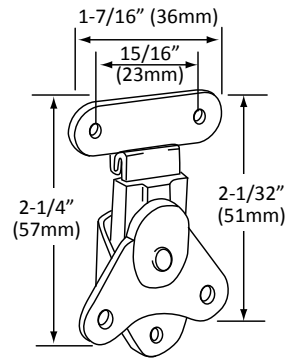

REF. D

HEAVY DUTY, STRAIGHT BACK DROP HANDLE, STAINLESS STEEL

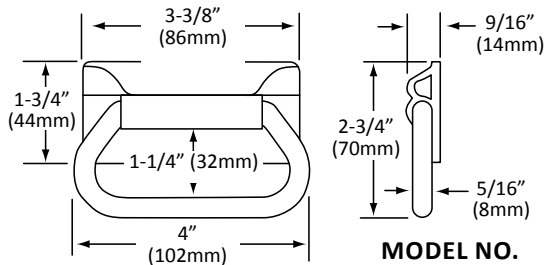

MODEL NO. P68-1010

REF. E

STRAIGHT BACK DROP HANDLE, STAINLESS STEEL

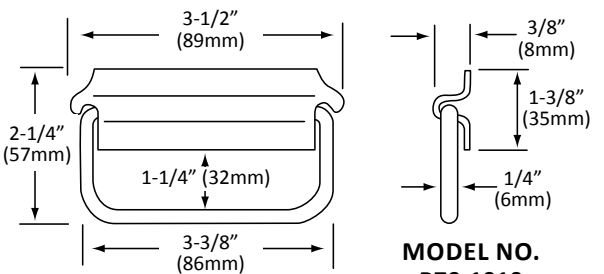

MODEL NO. P70-1010

REF. F

DRAWER-TITE ACTION CATCHES STAINLESS STEEL

MODEL NO.	LENGTH	WIDTH	HOLES
M10-8332	2-1/4" (57mm)	1" (25mm)	.132 (3mm)
M10-8333	3-3/8" (86mm)	1-1/4" (32mm)	.195 (5mm)

M10-8333

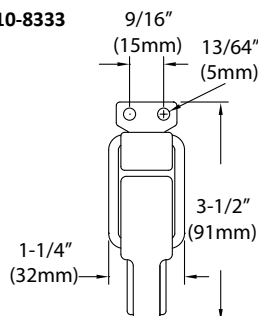

M10-8332

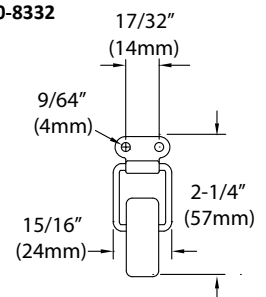

Cabinet Latches & Continuous Hinges

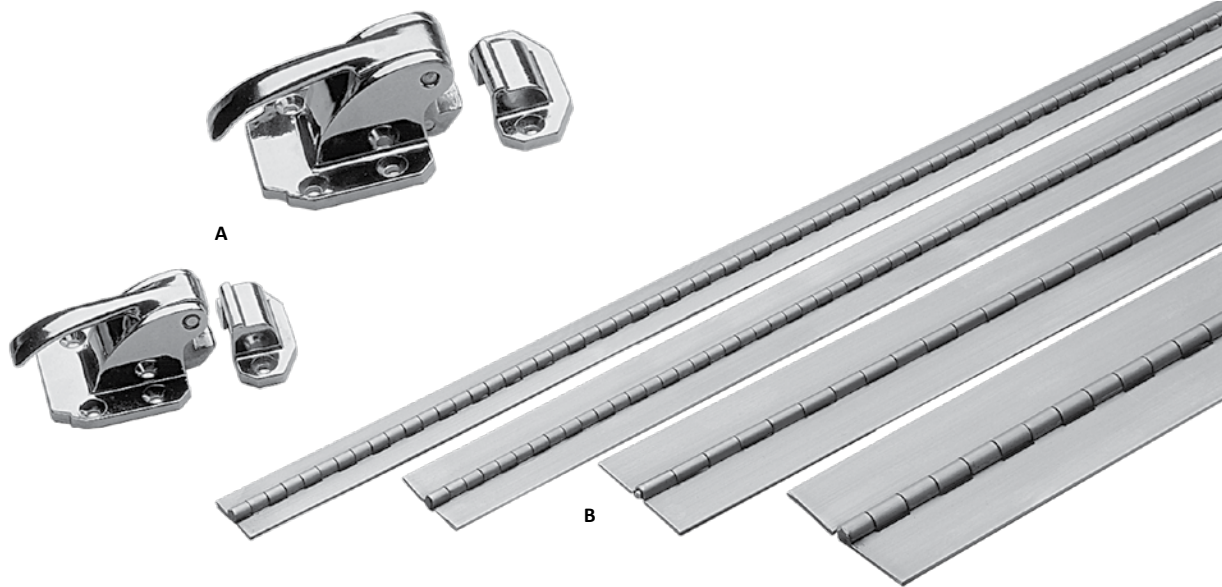

CABINET LATCHES, HANDLES LATCHES & CONTINUOUS HINGES

REF. A

CABINET LATCHES

- PROVIDED WITH FLUSH, 1/8" (3mm) and 3/8" (10mm) KEEPERS
- CHROME PLATED DIE CAST ZAMAK

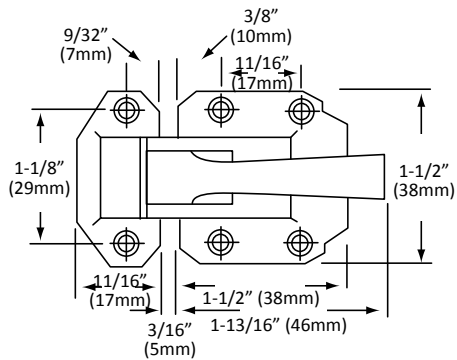

STANDARD DUTY

- MOUNTING HOLES Ø.150 THRU WITH Ø.279 X 82° CSK
- TOTAL 6 MOUNTING HOLES
- MOUNTING HOLES TO SUIT #6 FLAT HEAD SCREW

MODEL NO. M15-9210

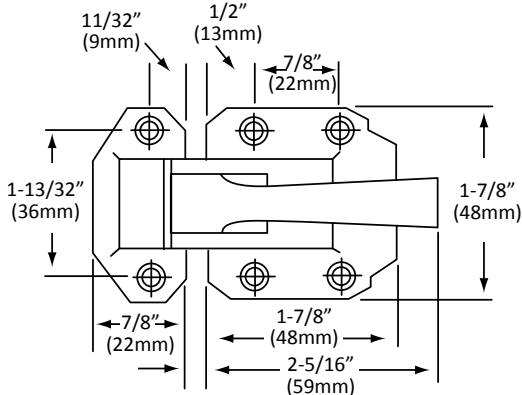

HEAVY DUTY

- MOUNTING HOLES Ø.177 THRU WITH Ø.332 X 82° CSK
- TOTAL 6 MOUNTING HOLES
- MOUNTING HOLES TO SUIT #8 FLAT HEAD SCREW

MODEL NO. M15-9211

REF. B

CONTINUOUS HINGE STAINLESS STEEL WITH STAINLESS STEEL PIN

MODEL NO.	WIDTH	LENGTH	GAUGE	PIN DIA.
M48-0112	3/4" (19mm)	72" (1829mm)	.035 (0.9mm)	.086 (2.2mm)
M48-0121	1-1/16" (27mm)	72" (1829mm)	.035 (0.9mm)	.086 (2.2mm)
M48-0122	1-1/16" (27mm)	72" (1829mm)	.040 (1.0mm)	.086 (2mm)
M48-0131	1-1/2" (38mm)	72" (1829mm)	.035 (0.9mm)	.090 (2.3mm)
M48-0132	1-1/2" (38mm)	72" (1829mm)	.040 (1.0mm)	.090 (2.3mm)
M48-0142	2" (51mm)	72" (1829mm)	.040 (1.0mm)	.120 (3mm)
M48-0143	2" (51mm)	72" (1829mm)	.050 (1.3mm)	.120 (3mm)
M48-0144	2" (51mm)	72" (1829mm)	.060 (1.5mm)	.120 (3mm)
M48-0154	2-1/2" (64mm)	72" (1829mm)	.060 (1.6mm)	.187 (4.8mm)
M48-0134	1-1/2" (38mm)	72" (1829mm)	.060 (1.6mm)	.125 (3.2mm)

NOTE:

HINGE FURNISHED WITHOUT HOLES. OTHER SIZES AVAILABLE UPON REQUEST.

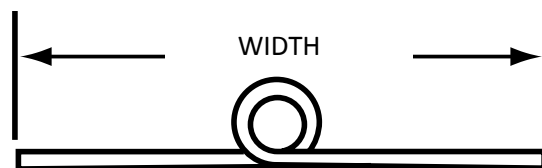

THREE POINT LATCH STAINLESS STEEL

- ALL STAINLESS STEEL CONSTRUCTION • POSITIVE DEAD BOLT LOCKING
- HOLDS DOOR CLOSED IN 3 PLACES-TOP, CENTER, & BOTTOM TO MINIMIZE LEAKAGE AND SAVE ENERGY
- STRONGEST LATCH MADE • SPRING LOADED OVER-CENTER LATCHING • POSITIVE INSIDE RELEASE MECHANISM

MODEL NO. W37-3000-SS

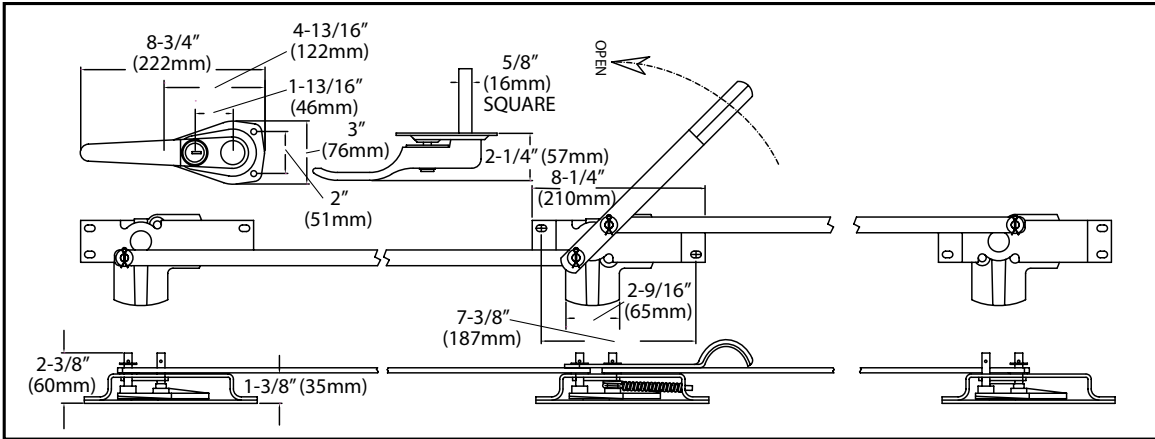
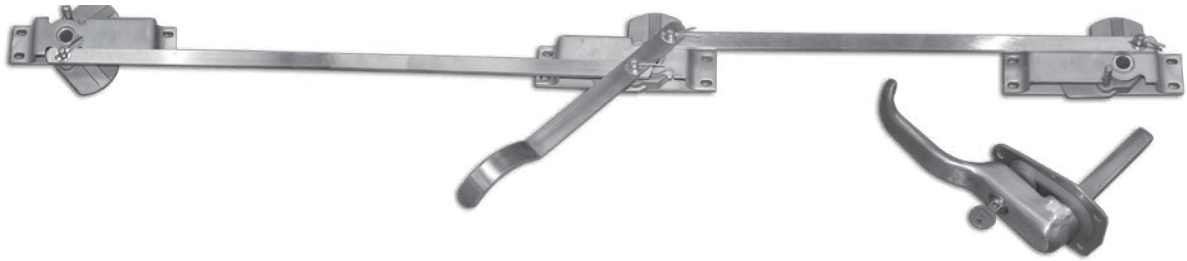

LIFT-OFF HINGES



LIFT-OFF FLAG HINGE

- SWEDGED KNUCKLE
- NON-HANDED
- STAINLESS STEEL and NYLON BEARING
- ELIMINATES MORTISING OF DOOR OR JAMB
- MINIMUM DOOR CLEARANCE REQUIRED

STANDARD DUTY

MODEL NO. M75-1002

2-1/16" (52mm) LG. x
1-3/32" (28mm) x .075 (2mm)
3/16" (5mm) PIN DIA.

HEAVY DUTY

MODEL NO. M75-5003

3" (76mm) LG. x
1-3/8" (35mm) x .075 (2mm)
1/4" (6mm) PIN DIA.

LIFT-OFF FLAG HINGE, STAINLESS STEEL

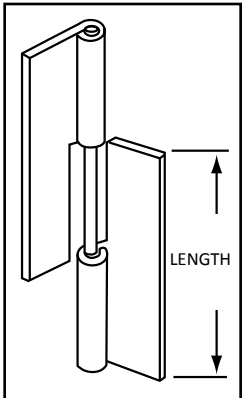

RIGHT HAND HINGE ILLUSTRATED

MODEL NO.	LENGTH	OPEN	GAUGE	PIN DIA.	HAND
R74-8000-RH	2" (51mm)	1-3/4" (44mm)	.075 (2mm)	3/16" (5mm)	R.H.
R74-8001-LH	2" (51mm)	1-3/4" (44mm)	.075 (2mm)	3/16" (5mm)	L.H.
R74-8100-RH	3" (76mm)	2" (51mm)	.075 (2mm)	3/16" (5mm)	R.H.
R74-8101-LH	3" (76mm)	2" (51mm)	.075 (2mm)	3/16" (5mm)	L.H.
R74-9000-RH	2" (51mm)	1-1/4" (32mm)	.060 (1.6mm)	1/8" (3mm)	R.H.
R74-9001-LH	2" (51mm)	1-1/4" (32mm)	.060 (1.6mm)	1/8" (3mm)	L.H.

NOTES: ALL HINGES ARE FURNISHED WITHOUT HOLES

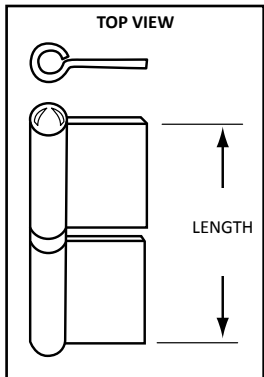

*May not be identical to competitors' products.

Hinges

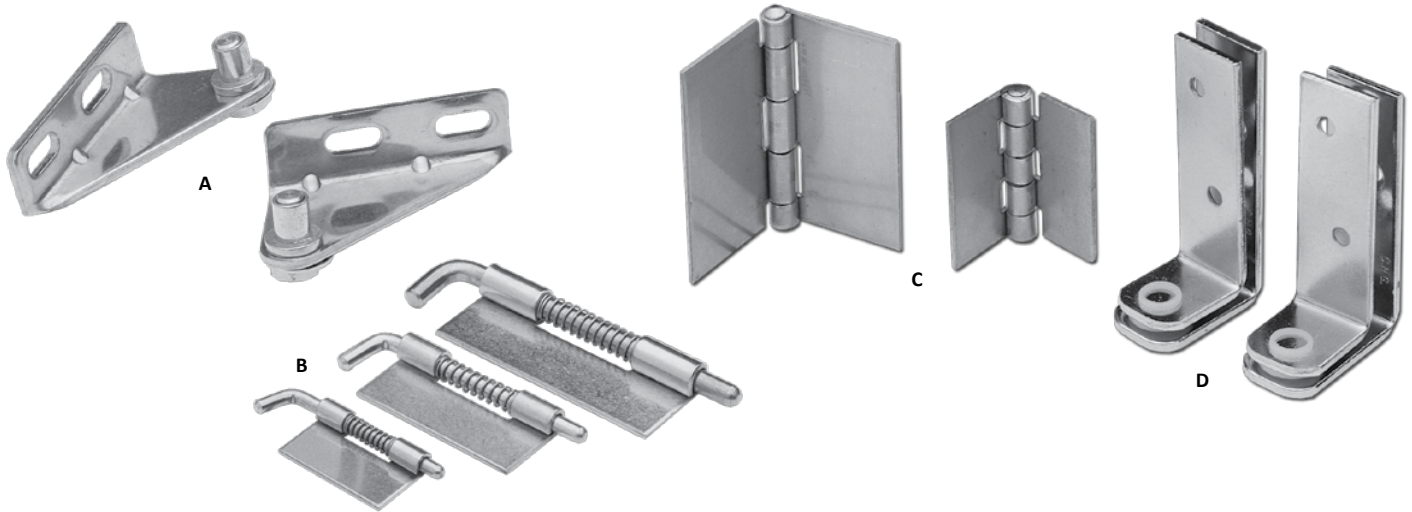

HINGES

REF. A

CONCEALED PIVOT HINGES STAINLESS STEEL

- OBLONG MOUNTING HOLES FOR EASY DOOR ADJUSTMENT
- SELF-LUBRICATING BRONZE PIVOT BUSHING
- REMOVABLE PIVOT PIN ALLOWS DOOR TO BE REMOVED WITHOUT DISASSEMBLING ENTIRE BRACKET
- SUPPLIED AS A SET...REVERSIBLE FOR LEFT OR RIGHT-HANDED DOORS

REPLACES* KASON #1510/11 AND #1530/31 WITH KEIL QUALITY HARDWARE

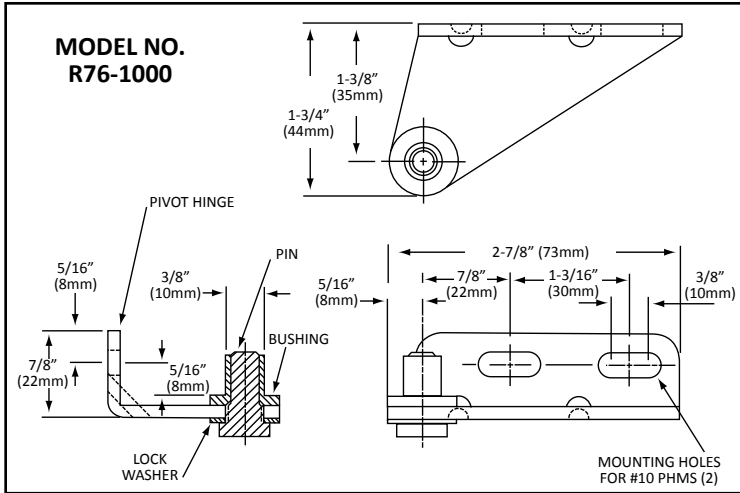

REF. B

RIGHT HAND LATCH HINGES STAINLESS STEEL

LEFT HAND MODELS AVAILABLE ON APPLICATION TO ORDER, ADD SUFFIX -LH

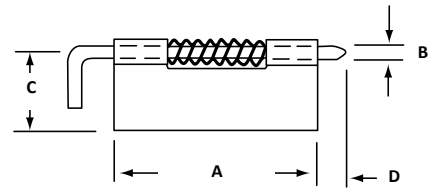

MODEL NO.	A	B	C	D	GAUGE
M12-9293	1-3/8" (35mm)	5/32" (4mm)	3/4" (19mm)	1/4" (6mm)	.040 (.1mm)
M12-9294	2" (51mm)	3/16" (5mm)	7/8" (22mm)	3/8" (10mm)	.050 (1mm)
M12-9295	2-3/4" (70mm)	1/4" (6mm)	1" (25mm)	1/2" (13mm)	.062 (2mm)

REF. C

BUTT HINGES STAINLESS STEEL

MODEL NO. M74-2078

2" (51mm) LG. x 2" (51mm) OPEN x 14 ga (2mm) .187 (5mm) PIN DIA.

MODEL NO. M74-3078

3" (76mm) LG. x 3" (76mm) OPEN x 14 ga (2mm) .187 (5mm) PIN DIA.

NOTE: HINGES ARE FURNISHED WITHOUT HOLES.

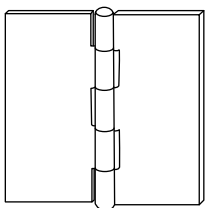

REF. D

PIVOT HINGES NICKEL PLATED STEEL

**SMALL OFFSET
MODEL NO. R75-6661**

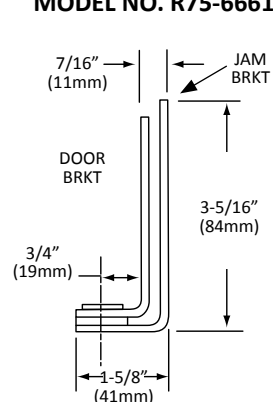

**LARGE OFFSET
MODEL NO. R75-6662**

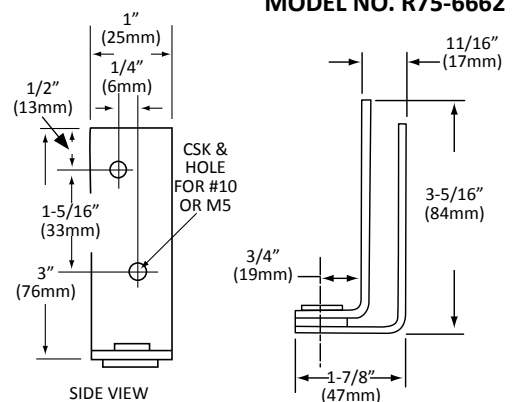



LOCKS

**UTILITY LOCKS
STAINLESS STEEL FACED**

- DISC TUMBLER
- FOUR BARREL LENGTHS AVAILABLE
- PERMITS MATERIAL THICKNESS TO 1-3/16" (30mm)
- KEY REMOVABLE IN LOCKED OR UNLOCKED POSITION
- FURNISHED WITH TWO KEYS

MODEL NO.	A	B	C	KEYING
P30-4750	9/32" (7mm)	5/8" (16mm)	7/8" (22mm)	ALIKE
P30-4751	9/32" (7mm)	5/8" (16mm)	7/8" (22mm)	DIFFERENT
P30-4752	9/32" (7mm)	5/8" (16mm)	7/8" (22mm)	DIFFERENT & MASTER KEYED
P30-4760	11/16" (17mm)	7/8" (22mm)	1-1/8" (28mm)	ALIKE
P30-4761	11/16" (17mm)	7/8" (22mm)	1-1/8" (28mm)	DIFFERENT
P30-4762	11/16" (17mm)	7/8" (22mm)	1-1/8" (28mm)	DIFFERENT & MASTER KEYED
P30-4770	15/16" (24mm)	1-1/8" (28mm)	1-3/8" (35mm)	ALIKE
P30-4771	15/16" (24mm)	1-1/8" (28mm)	1-3/8" (35mm)	DIFFERENT
P30-4772	15/16" (24mm)	1-1/8" (28mm)	1-3/8" (35mm)	DIFFERENT & MASTER KEYED
P30-4780	1-1/8" (28mm)	1-3/8" (35mm)	1-5/8" (41mm)	ALIKE
P30-4781	1-1/8" (28mm)	1-3/8" (35mm)	1-5/8" (41mm)	DIFFERENT

TO ORDER ADDITIONAL KEYS (KEYED-ALIKE-TYPE 802) USE **MODEL NO. P30-0802**
TO ORDER MASTER KEYS USE **MODEL NO. P30-1000**

NOTE: CAMS OPERATE IN 180° SEMI-CIRCLE. 90° OPERATING CAMS AVAILABLE UPON APPLICATION (ALSO AVAILABLE AS KEYED ALIKE IN SERIES). SPUR WASHERS FOR WOOD DRAWERS AVAILABLE ON SPECIAL ORDER.

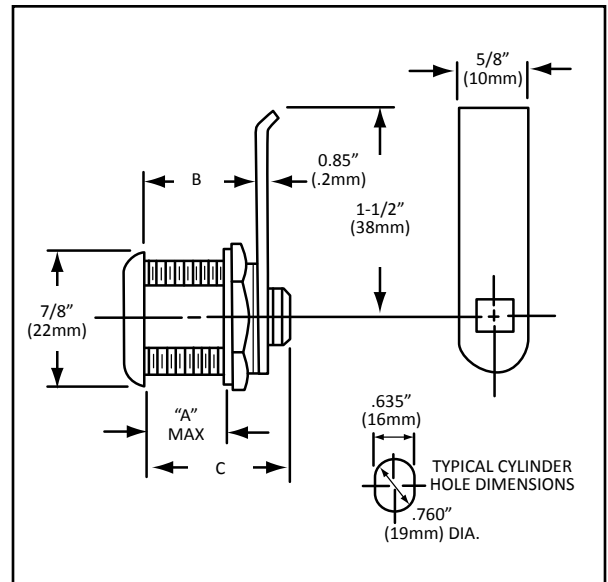

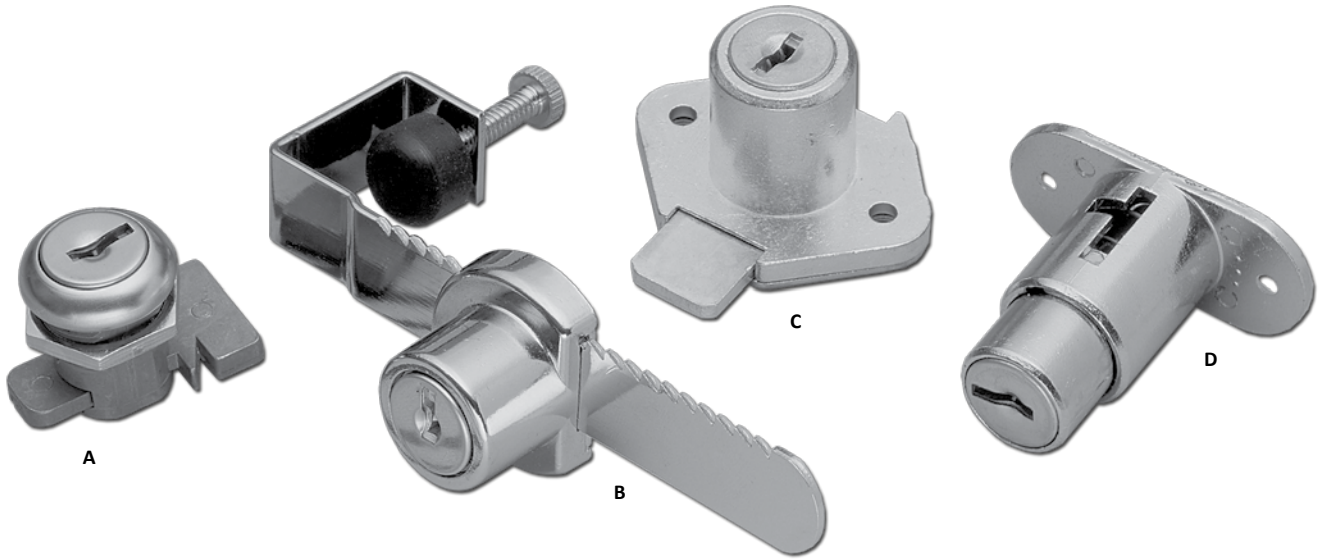

LOCKS

REF. A

T-BOLT LOCK STAINLESS STEEL FACED

- FIVE DISC TUMBLER
- FOR HOLLOW METAL DRAWERS AND FOAMED IN PLACE DOORS
- HEAVY-DUTY VERTICAL DEAD BOLT REMOVABLE FOR INSTALLATION
- FURNISHED WITH TWO BRASS KEYS

MODEL NO. P11-0480

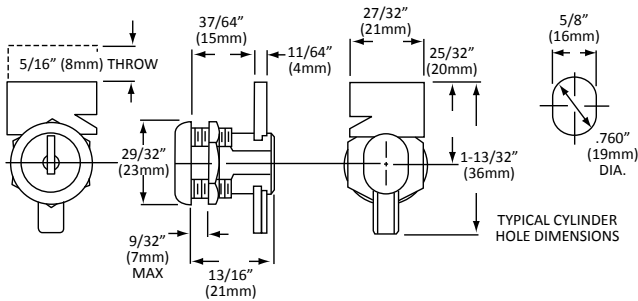

REF. B

SLIDING DOOR LOCK ADJUSTABLE

- POLISHED CHROME FINISH • TAMPERPROOF
- FOR GLASS DOORS UP TO 1-1/16" (17mm) THICK
- WOOD, WOOD FRAMED, OR METAL DOORS UP TO 1" (25mm) THICK
- RATCHET BAR IS TIGHTENED IN POSITION WITH THUMBSCREW

MODEL NO. P22-0006

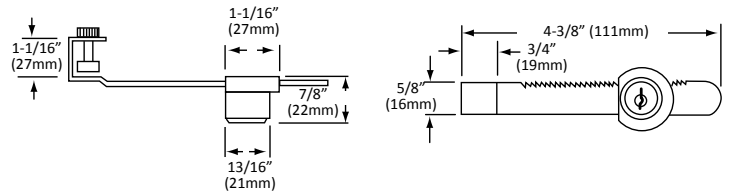

REF. C

DRAWER LOCK

- EASY TO INSTALL
- FIVE DISC TUMBLER
- NON FERROUS SATIN BRASS BARREL AND CASE
- FURNISHED WITH TWO BRASS KEYS

MODEL NO. P10-0370

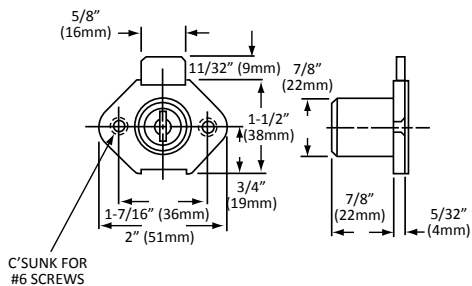

REF. D

PLUNGER LOCK

- NICKEL PLATED • FIVE DISC TUMBLER
- FOR BYPASSING DOORS APPROX. 3/4" (19mm) THICK AND OVER
- SUPPLIED WITH EASY TO INSTALL "PUSH-IN" BOLT RECEIVER
- LOCKING CYLINDER CANNOT BE REMOVED FROM HOUSING WITHOUT KEY

MODEL NO. P20-0490

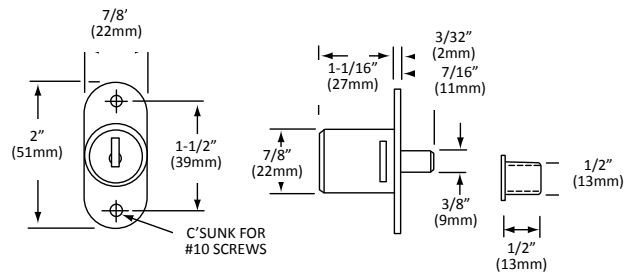

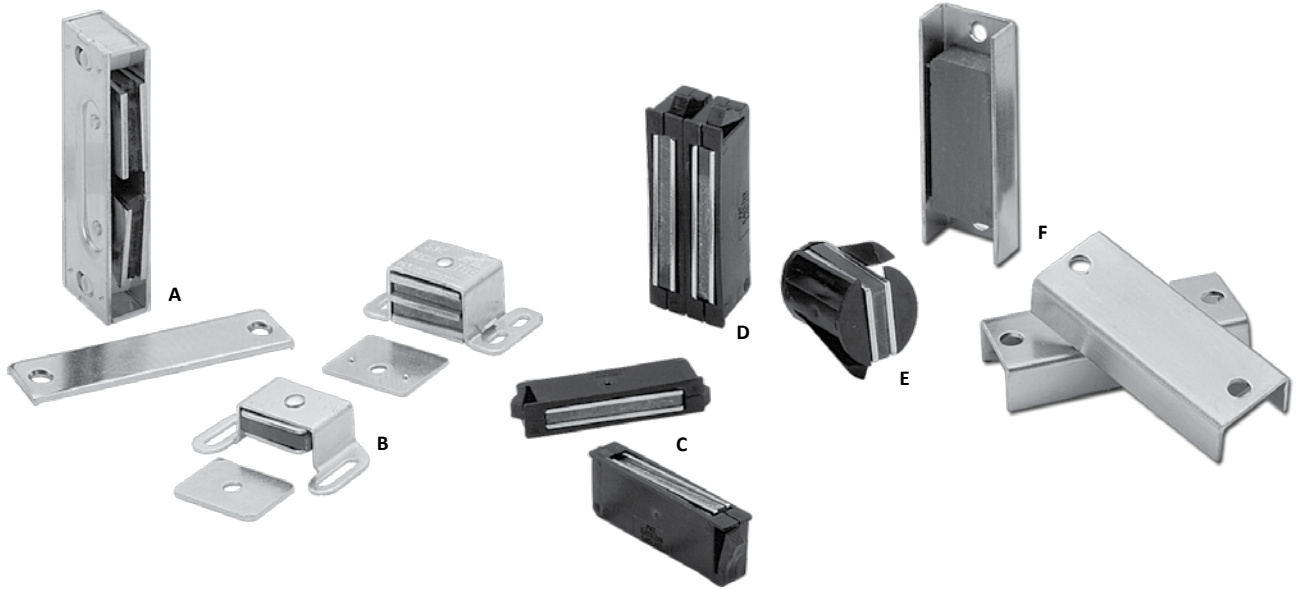

MAGNETIC CATCHES

REF. A

CABINET CATCH MAGNETIC

HEAVY DUTY
DOUBLE MAGNET

MODEL NO. M32-2401

MATERIAL: ALUMINUM
WITH CONCEALED MAGNETS
30 lbs (13.6 kg) PULL

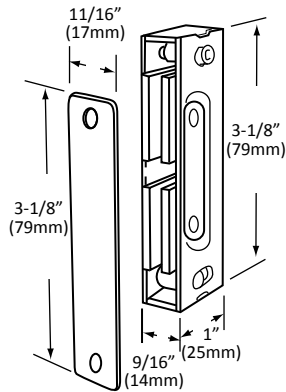

REF. B

CABINET CATCH MAGNETIC

SINGLE MAGNET

MODEL NO. M30-2400

SIZE: 2" x 1-1/16" x 1/2"
(51mm x 27mm x 13mm)
12 lbs (5 kg) PULL

DOUBLE MAGNET

MODEL NO. M30-5920

SIZE: 2" x 1-1/16" x 3/4"
(51mm x 27mm x 19mm)
20 lbs (9 kg) PULL

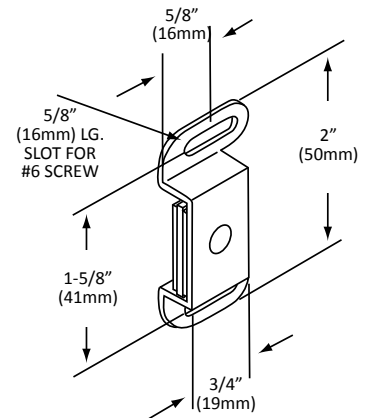

REF. C

CABINET CATCH MAGNETIC, SNAP-IN TYPE

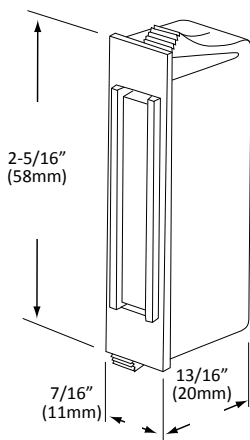

MODEL NO. M36-0201

MATERIAL: BLACK POLYPROPYLENE
WITH CONCEALED MAGNETS
12 lbs (5kg) PULL

REF. D

CABINET CATCH MAGNETIC, SNAP-IN TYPE

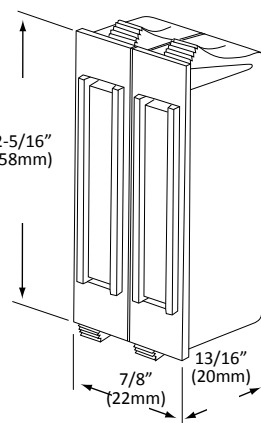

MODEL NO. M36-0801

MATERIAL: BLACK POLYPROPYLENE
WITH CONCEALED MAGNETS
30 lbs (13kg) PULL

REF. E

CABINET CATCH MAGNETIC, SNAP-IN TYPE

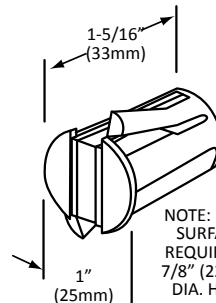

NOTE: MTG.
SURFACE
REQUIRES A
7/8" (22mm)
DIA. HOLE

MODEL NO. M36-0611

MATERIAL: BLACK POLYPROPYLENE
WITH CONCEALED MAGNETS
13 lbs (6kg) PULL

REF. F

CABINET CATCH MAGNETIC, CONCEALED TYPE

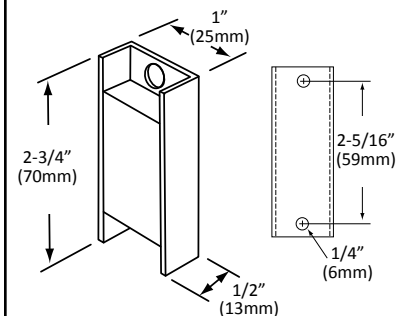

SINGLE CATCH MAGNET
MODEL NO. M35-1000

14 lbs (6kg) PULL
(STEEL BACKING PLATE REQUIRED)

FURNISHED AS SET OF TWO
WITH ATTRACTING POLARITY
FOR A STRONGER PULL
MODEL NO. M35-2000

MATERIAL: ZINC PLATED STEEL WITH
CONCEALED MAGNETS
• 18 lbs (8kg) PULL

Mechanical Catches

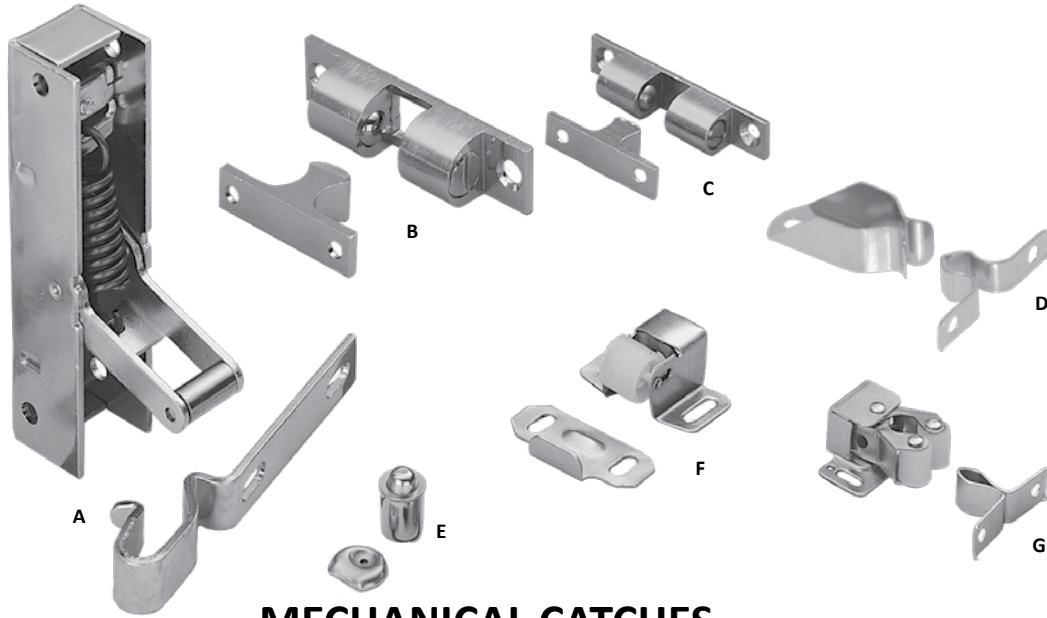

MECHANICAL CATCHES

REF. A

DOOR CATCH HEAVY-DUTY ADJUSTABLE TENSION

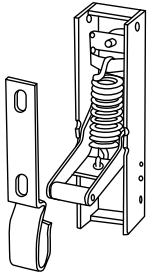

MODEL NO. M27-2490

8 lbs (3.6kg) PULL
SIZE: 1" X 4" (25mm x 102mm)
MATERIAL: STEEL, NICKEL PLATED

REF. B

DOOR CATCH HEAVY DUTY, 4 WAY* WITH ADJUSTABLE SPRING LOADED BALL TENSION

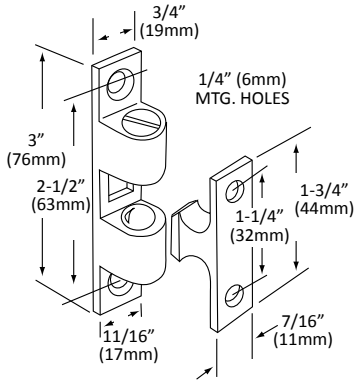

MODEL NO. M22-2430

MATERIAL: SOLID BRASS
WITH SATIN NICKEL FINISH
AND STAINLESS STEEL BALLS
*CATCH MAY BE USED FOR MORTISE
OR SURFACE MOUNT APPLICATION

REF. C

DOOR CATCH STANDARD DUTY WITH ADJUSTABLE SPRING LOADED BALL TENSION

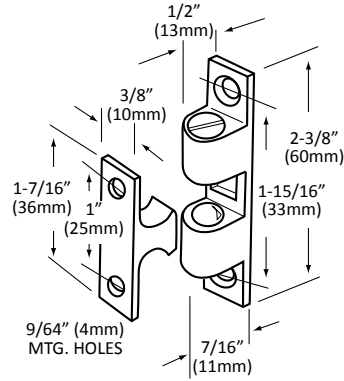

MODEL NO. M22-2420

MATERIAL: SOLID BRASS
WITH SATIN NICKEL FINISH
STAINLESS STEEL BALLS
AND SPRINGS

REF. D

DOOR CATCH FRICTION TYPE WITH SPRING STEEL ACTION

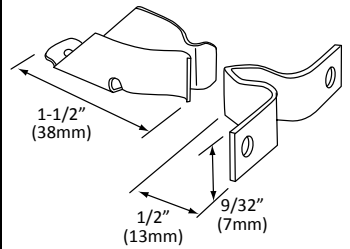

MODEL NO. M20-2590

MATERIAL: ZINC PLATED
SPRING STEEL

REF. E

BULLET CATCHES WITH FIXED TENSION

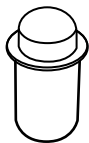

MODEL NO. M25-9469

SIZE: 3/8" X 7/16" (10mm x 11mm)
DIA. x LENGTH
MATERIAL: STEEL, NICKEL PLATED
FURNISHED WITH STRIKE

REF. F

SURFACE BOX CATCH WITH SPRING LOADED NYLON ROLLER

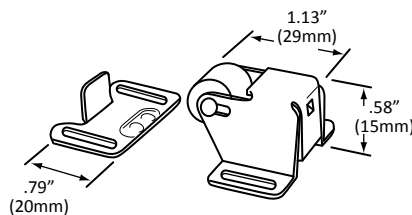

MODEL NO. M24-2260

MATERIAL: ZINC PLATED STEEL

REF. G

CABINET CATCH FRICTION TYPE WITH SPRING ACTION NYLON ROLLERS

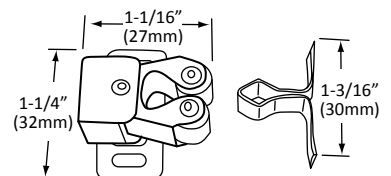

MODEL NO. M21-2580

MATERIAL: ZINC PLATED STEEL

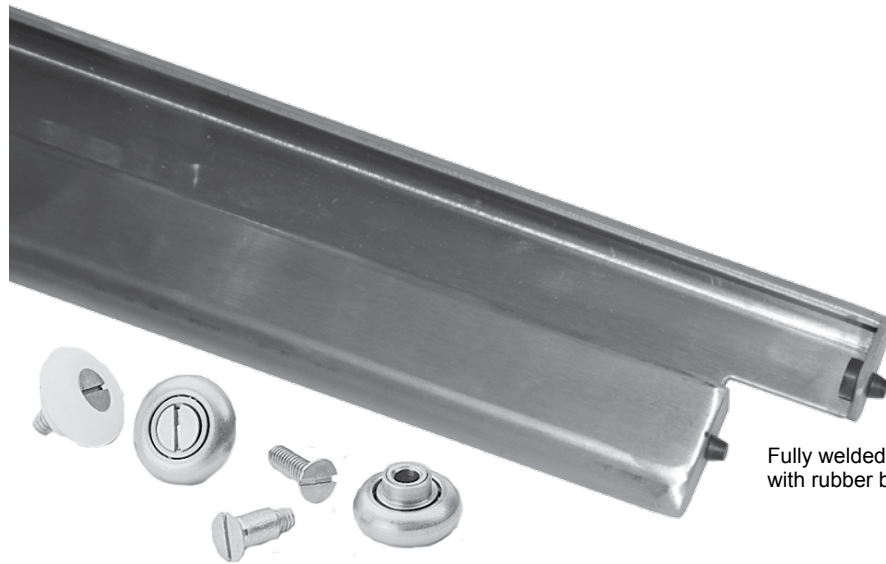

Fully welded end plates with rubber bumper stops

DRAWER SLIDES, EXTRA HEAVY -DUTY

S52 SERIES

- NSF LISTED
- STAINLESS STEEL FULL EXTENSION
- 200 lbs (100 kg) LOAD CAPACITY
- SLIDES AND ROLLERS EASILY REMOVED
- INCLUDES 8 BALL BEARING ASSEMBLIES
- RETAINER PLATES...KEEPS SLIDES IN POSITION EVEN WHEN DRAWERS ARE REMOVED
- FULLY WELDED STOPS

SPECIFICATIONS

MOUNTING	SIDE
SPACE REQUIRED	25/32" (20mm)
HEIGHT	2-7/16" (62mm)
DRAWER EXTENSION	FULL TRAVEL
LOAD CAPACITY	200 lbs (100kg) PER PAIR WITH STAINLESS STEEL BEARINGS 150 lbs (68kg) PER PAIR WITH DELRIN BEARINGS
MATERIAL	14 ga (2mm) STAINLESS STEEL
ACTION	SOLID DELRIN OR STAINLESS STEEL BALL BEARING WHEELS WITH REMOVABLE STAINLESS STEEL SCREWS

NOTE: LOAD RATING BASED ON 20"(500mm) SLIDE LENGTH
PACKAGED 6 PAIR PER CARTON

S52 SERIES STAINLESS STEEL FULL EXTENSION DRAWER SLIDES WITH STAINLESS STEEL BEARINGS

MODEL NO.	SIZE
S52-0020	20" (508mm)
S52-0022	22" (559mm)
S52-0024	24" (610mm)
S52-0026	26" (660mm)

S52 SERIES STAINLESS STEEL FULL EXTENSION DRAWER SLIDES WITH DELRIN BEARINGS

MODEL NO.	SIZE
S52-2020	20" (508mm)
S52-2022	22" (559mm)
S52-2024	24" (610mm)
S52-2026	26" (660mm)

NOTE: BOTH MODELS ARE FURNISHED WITH REMOVABLE STAINLESS STEEL THREADED FASTENERS

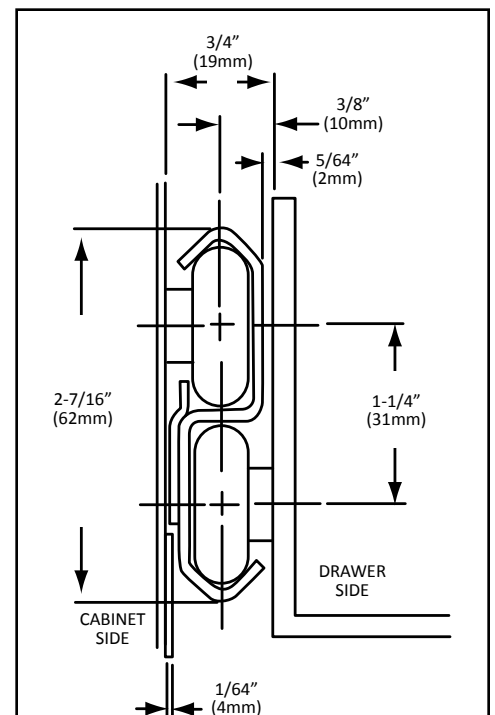

CROSS SECTION

WHEN ORDERING...MEASURE FROM INSIDE FACE TO EXTREME REAR OF DRAWER

NOTE: STAINLESS STEEL BALL BEARING ASSEMBLIES W/REMOVABLE STAINLESS STEEL THREADED FASTENERS (MODEL NO. S52-X001) AND DELRIN BEARING COMPLETE W/REMOVABLE STAINLESS STEEL THREADED FASTENERS (MODEL NO. S52-X101) MAY BE ORDERED SEPARATELY. SEE PAGE G30

Drawer Slides

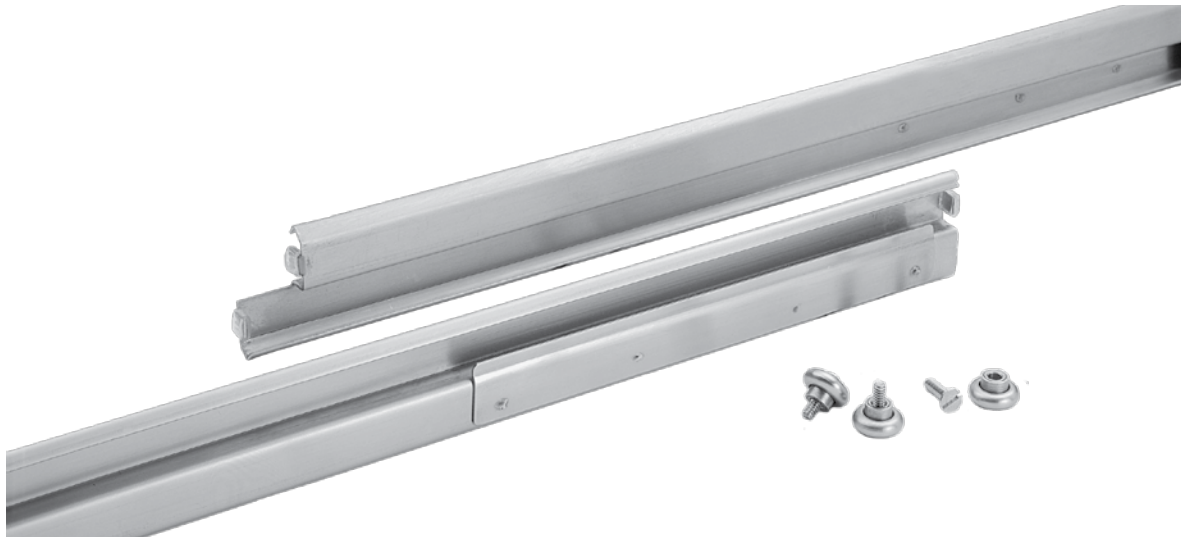

S26 STAINLESS STEEL SERIES

- NSF LISTED
- STAINLESS STEEL
- FULL EXTENSION
- 100 lbs (50kg) LOAD CAPACITY
- EASY INSTALLATION
- SLIDES & ROLLERS EASILY REMOVED FOR CLEANING
- INCLUDES (8) S/S BALL BEARING ASSEMBLIES
- RETAINER PLATES...KEEPS SLIDES IN POSITION EVEN WHEN DRAWERS ARE REMOVED
- POSITIVE STOPS

SPECIFICATIONS

MOUNTING	SIDE
SPACE REQUIRED	5/8" (15mm)
HEIGHT	1-27/32" (21mm)
DRAWER EXTENSION	FULL TRAVEL
LOAD CAPACITY	100 lbs (45kg) PER PAIR
ACTION	STAINLESS STEEL BALL BEARING WHEELS WITH REMOVABLE STAINLESS STEEL SCREWS

NOTE: LOAD RATING BASED ON 20" (508mm) SLIDE LENGTH
PACKAGED 10 PAIR PER CARTON

S10 ECONOMICAL SERIES

- NSF LISTED
- ECONOMICAL ZINC PLATED STEEL
- FULL EXTENSION
- 100 lbs (50kg) LOAD CAPACITY
- EASY INSTALLATION
- SLIDES & ROLLERS EASILY REMOVED FOR CLEANING
- INCLUDES (8) BALL BEARING ASSEMBLIES
- RETAINER PLATES...KEEPS SLIDES IN POSITION EVEN WHEN DRAWERS ARE REMOVED
- POSITIVE STOPS

SPECIFICATIONS

MOUNTING	SIDE
SPACE REQUIRED	5/8" (15mm)
HEIGHT	1-27/32" (21mm)
DRAWER EXTENSION	FULL TRAVEL
LOAD CAPACITY	100 lbs (45kg) PER PAIR
MATERIAL	COLD ROLLED ZINC PLATED STEEL
ACTION	ZINC PLATED STEEL BALL BEARING WHEELS WITH REMOVABLE ZINC PLATED STEEL SCREWS

NOTE: LOAD RATING BASED ON 20" (508mm) SLIDE LENGTH
PACKAGED 10 PAIR PER CARTON

S26 SERIES STAINLESS STEEL FULL EXTENSION DRAWER SLIDES WITH STAINLESS STEEL BEARINGS

MODEL NO.	SIZE
S26-0014	14" (356mm)
S26-0016	16" (406mm)
S26-0018	18" (457mm)
S26-0020	20" (508mm)
S26-0022	22" (559mm)
S26-0026	26" (660mm)

NOTE: STAINLESS STEEL BALL BEARING ASSEMBLIES WITH REMOVABLE STAINLESS STEEL THREADED FASTENERS MAY BE ORDERED SEPARATELY.
SEE PG.G30 (MODEL NO. S26-Y001)

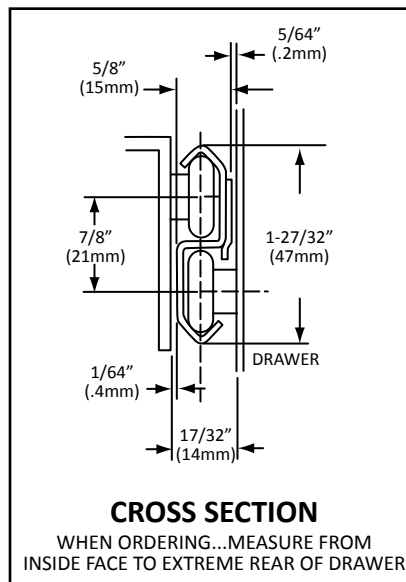

S10 SERIES ZINC PLATED FULL EXTENSION DRAWER SLIDES WITH ZINC PLATED BEARINGS

MODEL NO.	SIZE
S10-0014	14" (356mm)
S10-0016	16" (406mm)
S10-0018	18" (457mm)
S10-0020	20" (508mm)
S10-0022	22" (559mm)
S10-0024	24" (610mm)
S10-0026	26" (660mm)

NOTE: ZINC PLATED STEEL BALL BEARING ASSEMBLIES WITH REMOVABLE ZINC PLATED STEEL THREADED FASTENERS MAY BE ORDERED SEPARATELY.
SEE PG. G30 (MODEL NO. S10-Y001)



S25 STAINLESS STEEL DRAWER SLIDES

S25 SERIES

- NSF LISTED
- STAINLESS STEEL
- BALL BEARING ACTION
- 150 lbs (68kg) LOAD CAPACITY
- POSITIVE STOPS
- FINGER TIP LEVER DRAWER RELEASE

SPECIFICATIONS

MOUNTING	SIDE
SPACE REQUIRED	9/16" (14mm)
HEIGHT	3" (76mm)
DRAWER EXTENSION	LENGTH OF SLIDE MINUS 4-1/4" (107mm)
LOAD CAPACITY	150 lbs (68kg) PER PAIR**
ACTION	STAINLESS STEEL BALL BEARING WHEELS WITH REMOVABLE STAINLESS STEEL SCREWS

PACKAGED 10 PAIR PER CARTON

*S25 SERIES STAINLESS STEEL DRAWER SLIDES WITH STAINLESS STEEL BEARINGS

SIZE	MODEL NO.
S25-0012	12" (305mm)
S25-0014	14" (356mm)
S25-0016	16" (406mm)
S25-0018	18" (457mm)
S25-0020	20" (508mm)
S25-0022	22" (559mm)
S25-0024	24" (610mm)
S25-0026	26" (660mm)
S25-0028	28" (711mm)

*S25 SERIES STAINLESS STEEL DRAWER SLIDES WITH S/S BEARINGS W/ NYLON TIRE

SIZE	MODEL NO.
S25-2012	12" (305mm)
S25-2014	14" (356mm)
S25-2016	16" (406mm)
S25-2020	20" (508mm)
S25-2022	22" (559mm)
S25-2024	24" (610mm)
S25-2026	26" (660mm)
S25-2028	28" (711mm)

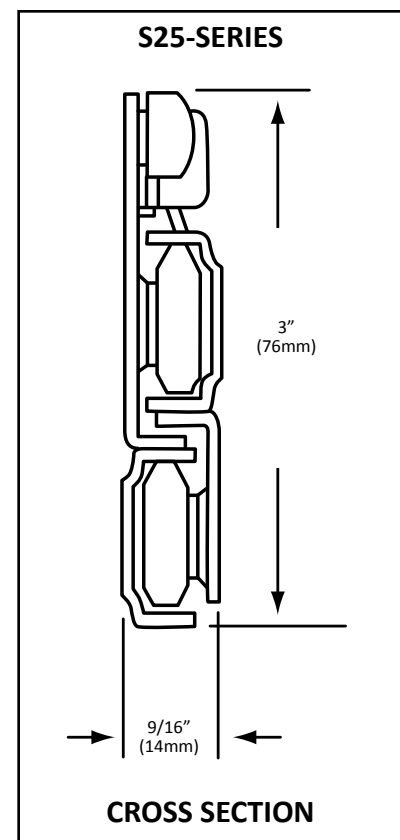

*EQUIVALENT TO STANDARD-KEIL SERIES 1425

**LOAD RATING BASED ON 18" (457mm) SLIDE LENGTH

NOTE: WHEN ORDERING, MEASURE FROM INSIDE FACE TO EXTREME REAR OF DRAWER

Drawer Slides



DRAWER SLIDES, 1/2" (13mm) CLEARANCE

S15 SERIES

- ZINC PLATED STEEL
- 75 lbs (40kg) LOAD CAPACITY
- ALLOWS DRAWER TO BE EASILY REMOVED



SPECIFICATIONS

MOUNTING

SPACE REQUIRED

HEIGHT

DRAWER EXTENSION

LOAD CAPACITY

MATERIAL

ACTION

ADDITIONAL

SIDE

1/2" (13mm)

3" (76mm)

LENGTH OF SLIDE MINUS 4-1/4" (107mm)

75 lbs (40kg) PER PAIR

COLD ROLLED STEEL, ZINC PLATED,

CLEAR CHROMATE

NYLON BALL BEARING ROLLERS

POSITIVE STOPS, FINGER TIP RELEASE,

REMOVABLE

NOTE: LOAD RATING BASED ON 18" (457mm) SLIDE LENGTH
PACKAGED 10 PAIR PER CARTON

S15 SERIES STEEL ZINC PLATED DRAWER SLIDES

MODEL NO.	SIZE
S15-1012	12" (305mm)
S15-1014	14" (356mm)
S15-1016	16" (406mm)
S15-1018	18" (457mm)
S15-1020	20" (508mm)
S15-1022	22" (559mm)
S15-1024	24" (610mm)
S15-1026	26" (660mm)

NOTE: WHEN ORDERING, MEASURE FROM INSIDE
FACE TO EXTREME REAR OF DRAWER .

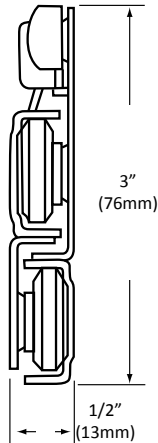

S35 SERIES

- ZINC PLATED STEEL • FULL EXTENSION
- 100 lbs (50kg) LOAD CAPACITY • NO DEFLECTION
- ALLOWS DRAWER TO BE EASILY REMOVED

SPECIFICATIONS

MOUNTING

SPACE REQUIRED

HEIGHT

DRAWER EXTENSION

LOAD CAPACITY

MATERIAL

ACTION

ADDITIONAL

SIDE

1/2" (13mm)

2-3/8" (60mm)

FULL TRAVEL

100 lbs (50kg) PER PAIR

COLD ROLLED STEEL, ZINC PLATED,

CLEAR CHROMATE

FRONT INTERMEDIATE WHEEL: NYLON

ROLLER OUTER CHANNEL ASSEMBLY:

STEEL BALL BEARING

POSITIVE MECHANICAL STOP, FULL

EXTENSION WITH VIRTUALLY NO

DEFLECTION, REMOVABLE

NOTE: LOAD RATING BASED ON 18" (457mm) SLIDE LENGTH
PACKAGED 10 PAIR PER CARTON

S35 SERIES ZINC PLATED STEEL FULL EXTENSION DRAWER SLIDES

MODEL NO.	SIZE
S35-1016	16" (406mm)
S35-1018	18" (457mm)
S35-1020	20" (508mm)
S35-1022	22" (559mm)
S35-1024	24" (610mm)
S35-1026	26" (660mm)

NOTE: WHEN ORDERING, MEASURE FROM INSIDE
FACE TO EXTREME REAR OF DRAWER .

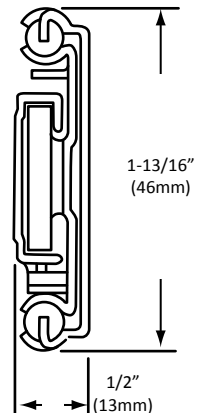

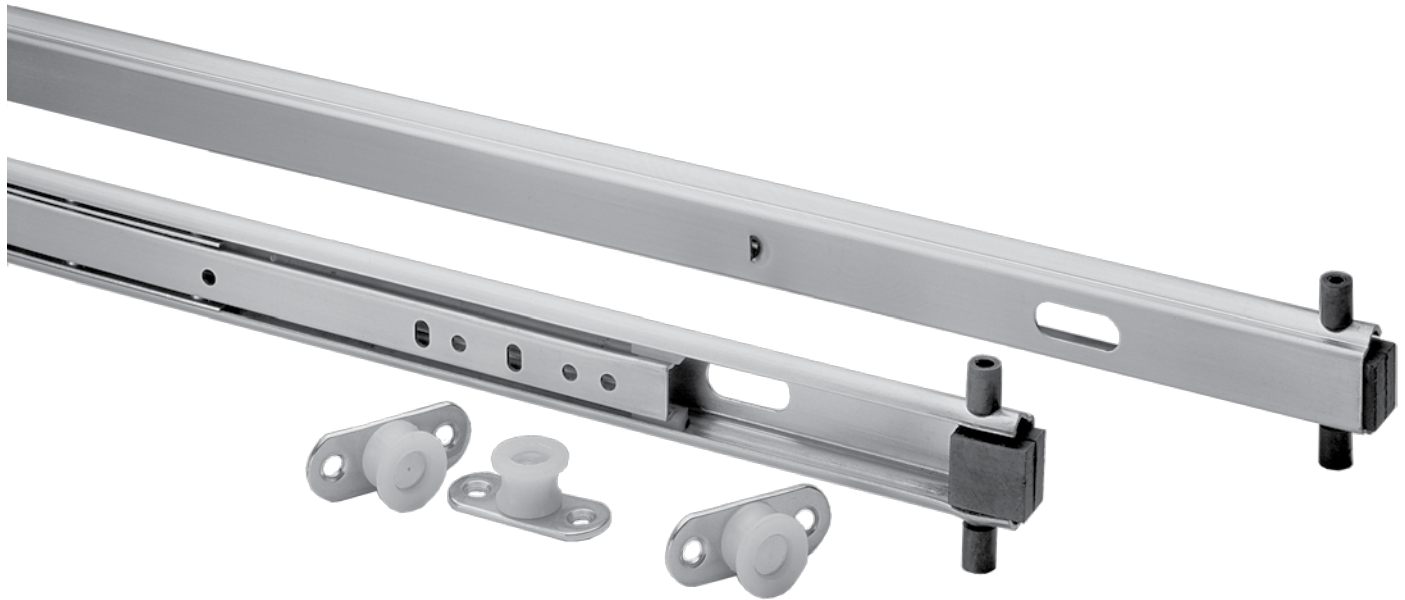

DRAWER SLIDES, 3/4" (19mm) CLEARANCE

S30 SERIES

- ZINC PLATED STEEL
- FULL EXTENSION
- 75 lbs (40kg) LOAD CAPACITY
- ALLOWS DRAWER TO BE EASILY REMOVED

SPECIFICATIONS

MOUNTING
SPACE REQUIRED
HEIGHT

SIDE
3/4" (19mm)
2-1/32" (52mm) WITH ROLLERS
1-1/4" (32mm) WITHOUT ROLLERS

DRAWER EXTENSION
LOAD CAPACITY

FULL TRAVEL, CONTROLLED BY ROLLER REPLACEMENT
75 lbs (40kg) PER PAIR

MATERIAL

ZINC PLATED STEEL

ACTION

NYLON OR NON-CORROSIVE METAL ROLLERS

ADDITIONAL FEATURES

NON-HANDED, REMOVABLE (WITH ROLLERS),
RUBBER STOPS

NOTE: LOAD RATING BASED ON 18" (457mm) SLIDE LENGTH
PACKAGED 10 PAIR PER CARTON

S30 SERIES ZINC PLATED STEEL FULL EXTENSION DRAWER SLIDES

SIZE	MODEL NO. WITH NYLON ROLLERS	MODEL NO. WITH METAL ROLLERS	MODEL NO. WITHOUT ROLLERS
18" (457mm)	S30-1018	S30-3018	S30-2018
20" (508mm)	S30-1020	S30-3020	S30-2020
22" (559mm)	S30-1022	S30-3022	S30-2022
24" (610mm)	S30-1024	S30-3024	S30-2024

ACCESSORIES:

S30-Y001
S30-Y002

NYLON ROLLER (EA)
Metal Roller (ea)
(4 rollers required per pair)

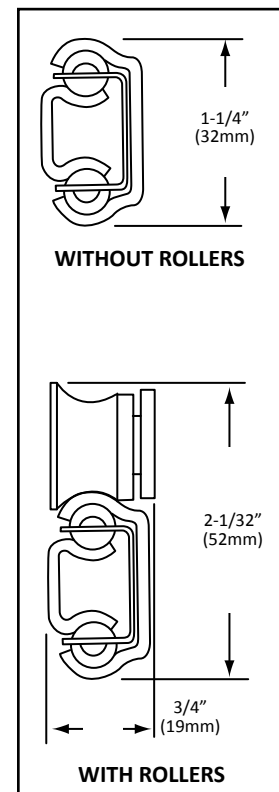



DRAWER PANS



DRAWER PANS STAINLESS STEEL

- STAINLESS STEEL WITH POLISHED FINISH
- COVED CORNERS • TWO SIZES AVAILABLE
- FOR USE IN FOOD SERVICE TABLES AND FOOD WARMERS
- IDEAL FOR UTENSILS AND FROZEN FOOD STORAGE
- MEETS NSF CRITERIA

STAINLESS STEEL DRAWER PANS

MODEL NO.	NOMINAL DIMENSIONS	FLANGE SIZE
S81-1520-C	15" x 20" x 5" (381mm x 508mm x 127mm)	16 x 21-1/2" (406mm x 546mm)
S81-2020-C	20" x 20" x 5" (508mm x 508mm x 127mm)	21-1/2" x 21-1/2" (546mm x 546mm)

PACKAGED 6 TO A MASTER CARTON
NOTE: OTHER DEPTHS AVAILABLE UPON APPLICATION.

DRAWER PANS HEAVY-DUTY THERMOPLASTIC

HEAVY-DUTY THERMOPLASTIC DRAWER PANS

MODEL NO.	NOMINAL DIMENSIONS	FLANGE SIZE
S80-1520	15" x 20" x 5" (381mm x 508mm x 127mm)	16-1/4" x 21-3/4" (415mm x 550mm)
S80-2020	20" x 20" x 5" (508mm x 508mm x 127mm)	21-3/4" x 21-3/4" (550mm x 550mm)

PACKAGED 6 TO A MASTER CARTON

Stainless Steel Drawer Assembly

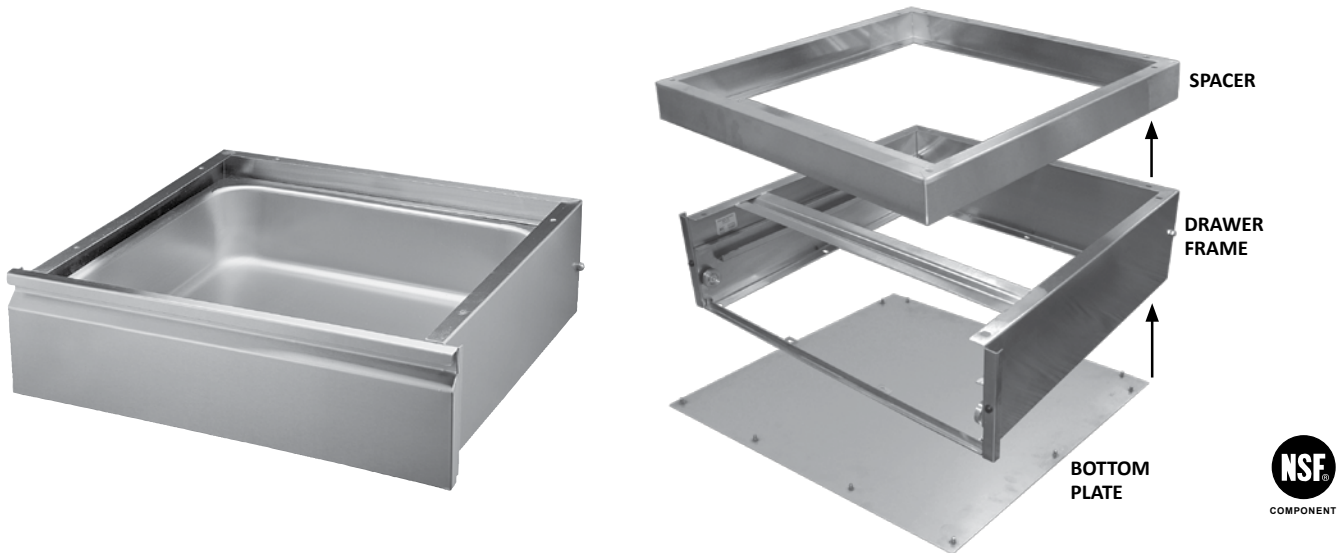

HEAVY DUTY S90 SERIES STAINLESS STEEL DRAWER ASSEMBLIES

- STAINLESS STEEL, WELDED CONSTRUCTION THROUGHOUT
- S90 HEAVY DUTY 19 GA. OUTER DRAWER HOUSING WITH 17 GA. INTERNAL FRAME ASSEMBLY AND FRONT PANEL
- SE90 MEDIUM DUTY 20 GA. OUTER DRAWER HOUSING WITH 19 GA. INTERNAL FRAME ASSEMBLY AND FRONT PANEL
- UNIQUE UNI-BODY CONSTRUCTION ALLOWS UNITS TO BE STACKED
- CONVENIENT, PRECISE MOUNTING HOLES OFFER QUICK, EASY INSTALLATION
- 200 lb CAPACITY
- SELF-CLOSING DRAWER FEATURE
- ENTIRE DRAWER ASSEMBLY DEBURRED AND READY TO INSTALL
- COMPLETE WITH HEAVY GAUGE REMOVABLE STAINLESS STEEL OR PLASTIC PAN
- FULL EXTENSION- 90° PULL ALLOWS CONVENIENT ACCESS AND IS EASY TO KEEP CLEAN
- AVAILABLE WITH OR WITHOUT CYLINDER LOCK ASSEMBLY
- SPECIFICATION GRADE, MEETS MOST ARCHITECTURAL REQUIREMENTS

15" S/S DRAWER ASSEMBLY

MODEL NO.	DESCRIPTION	LOCK	PAN
*S90-0015-N *SE90-0015-N	15" (381mm) PAN	-	S/S
*S90-0015-C-N *SE90-0015-C-N	15" (381mm) PAN	CYLINDER	S/S

MODEL NO.		A	B	C	D
S90-0015 SE90-0015	DIM. FOR 15" ASS'Y	17-3/4" (451mm)	16-1/2" (419mm)	13-5/8" (346mm)	19-5/16" (497mm)
S90-0020 SE90-0020	DIM. FOR 20" ASS'Y	23-3/8" (594mm)	22-1/8" (562mm)	19-1/4" (489mm)	25-1/16" (636mm)

20" S/S DRAWER ASSEMBLY

MODEL NO.	DESCRIPTION	LOCK	PAN
*S90-0020-N *SE90-0020-N	20" (508mm) PAN	-	S/S
*S90-0020-C-N *SE90-0020-C-N	20" (508mm) PAN	CYLINDER	S/S

*NSF LISTING APPLIES TO DRAWER ASSEMBLIES UTILIZING STAINLESS STEEL PANS ONLY.

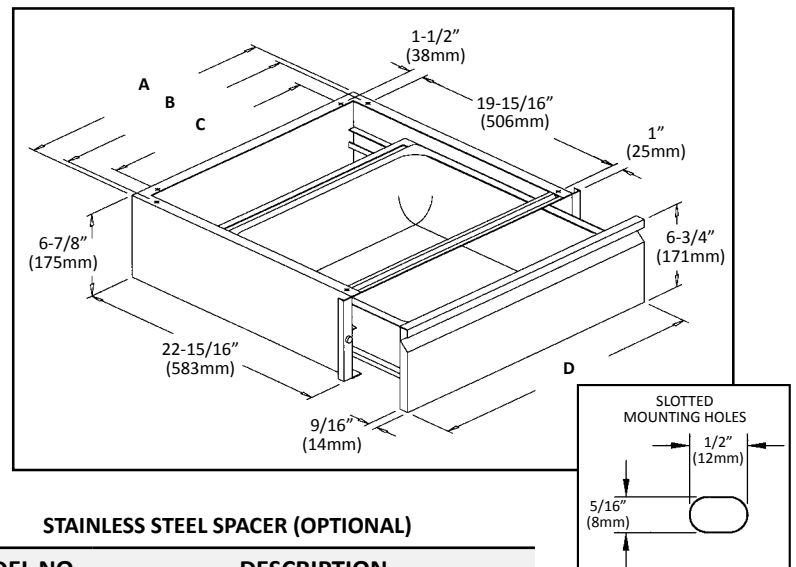

STAINLESS STEEL BOTTOM PLATE (OPTIONAL)*

MODEL NO.	DESCRIPTION
S90-X030	20" x 20" (508mm x 508mm)

STAINLESS STEEL SPACER (OPTIONAL)

MODEL NO.	DESCRIPTION
S90-X032	20" x 20" x 2-1/2" (508mm x 508mm x 64mm)
S90-X033	15" x 20" x 2-1/2" (381mm x 508mm x 64mm)

*USED TO DROP THE DRAWER BELOW NORMAL 2" RETURN ON TABLE TOP OR AS A MULLION BETWEEN DRAWERS

Cash Drawer Assembly



A



B

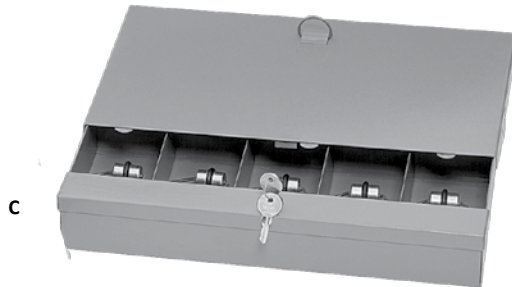

C

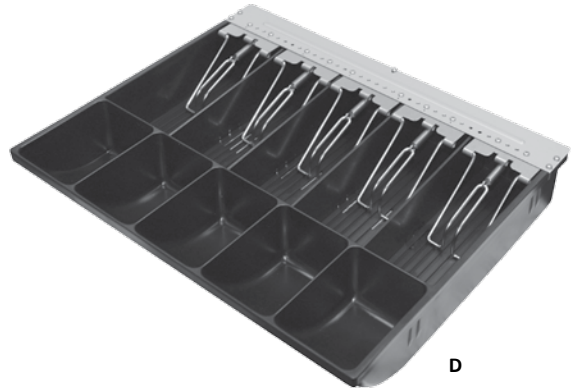

D

STAINLESS STEEL CASH DRAWER ASSEMBLY

REF. A

CASH DRAWER ASSEMBLY WITH TRAY MODEL NO. S95-1000

- STAINLESS STEEL SPECIFICATION GRADE CASH DRAWER ASSEMBLY
 - SOLID STAINLESS STEEL CONSTRUCTION
- FULL EXTENSION DRAWER SLIDE OFFERS EASE OF OPERATION
- ALL DRAWERS FURNISHED WITH STAINLESS STEEL FACED CYLINDER LOCKS DESIGNED FOR EASY UNDERCOUNTER MOUNTING
 - SMOOTH AND QUIET OPERATION

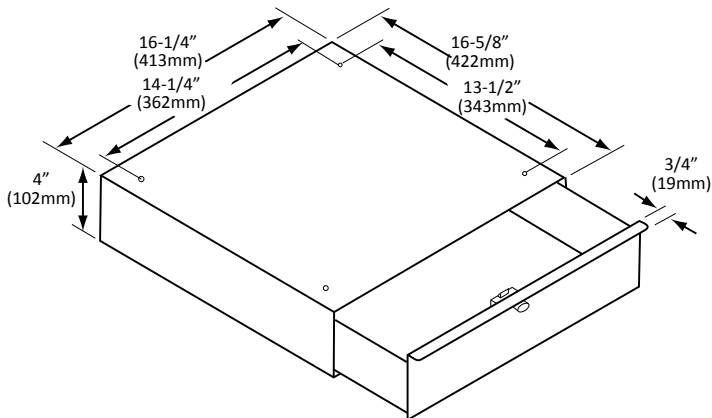

REF. B

CASH DRAWER ASSEMBLY WITH TRAY MODEL NO. CD-1000

- BLACK POWDER COATED FINISH
- CENTER SECURITY DRAWER KEY-LOCK
- STANDARD ABS PLASTIC 5 COIN/5 BILL REMOVABLE MONEY TRAY INSERT • ADJUSTABLE BILL SEPARATOR FOR FOREIGN CURRENCY • STAINLESS STEEL MONEY CLIPS
- STAINLESS STEEL COIN BREAKING PLATE • SLOTS ON DRAWER FACE FOR CHECKS/RECEIPTS/COUPONS
- DRAWER BELL • NON-SKID 1/2" RUBBER FEET

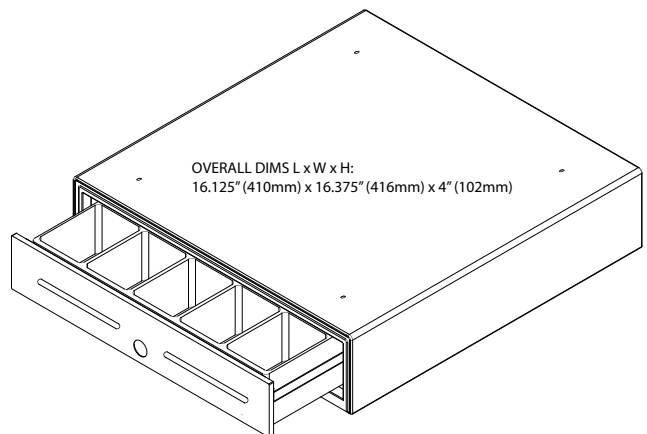

REF. C

CURRENCY TRAY WITH COVER MODEL NO. S95-Y002

- REMOVABLE CURRENCY TRAY WITH DROP HANDLE FOR EASY REMOVAL • DESIGNED TO ACCOMMODATE PORTABLE CASH NEEDS-IDEAL FOR DRAWERS, SAFES AND DESKS
 - POSITIVE SPRING ACTION MONEY HOLD DOWN
 - LOCK WITH STAINLESS STEEL CYLINDER

STAINLESS STEEL CASH DRAWER LESS CURRENCY TRAY MODEL NO. S95-Y001

REF. D

REPLACEMENT CURRENCY TRAY MODEL NO. CD-Y004

- STANDARD ABS PLASTIC 5 COIN/5 BILL REMOVABLE MONEY TRAY INSERT • ADJUSTABLE BILL SEPARATOR FOR FOREIGN CURRENCY • STAINLESS STEEL MONEY CLIPS

KEY FOR CASH DRAWER ASSEMBLIES -
MODEL NO. S95-Y001-KEY
KEY FOR CURRENCY TRAY ASSEMBLIES -
MODEL NO. S95-Y002-KEY



DRAWER FRONTS & BRACKETS

DRAWER FRONTS HEAVY-DUTY STAINLESS STEEL

- STAINLESS STEEL 20 GAUGE
 - No. 4 POLISHED FINISH
- FULL GRIP BEVELED EDGE PULL
- FURNISHED WITH (6) #10-24 WELD STUDS

HEAVY-DUTY STAINLESS STEEL DRAWER FRONTS

MODEL NO.	DIMENSIONS	WELD STUD CENTERS
J85-2000	23-1/8" x 6-1/2" (590mm x 165mm)	19-5/8" x 3" (498mm x 76mm)

ANGLE BRACKET DRAWER ASSEMBLY KIT

- CONVENIENT...READY TO USE
J85-2000 DRAWER FRONT

ANGLE BRACKET DRAWER ASSEMBLY KIT MODEL NO. J85-1000

THE ANGLE BRACKET DRAWER ASSEMBLY KIT IS AN OPTIONAL ACCESSORY FOR MOUNTING DRAWER FRONT TO DRAWER HOUSING.

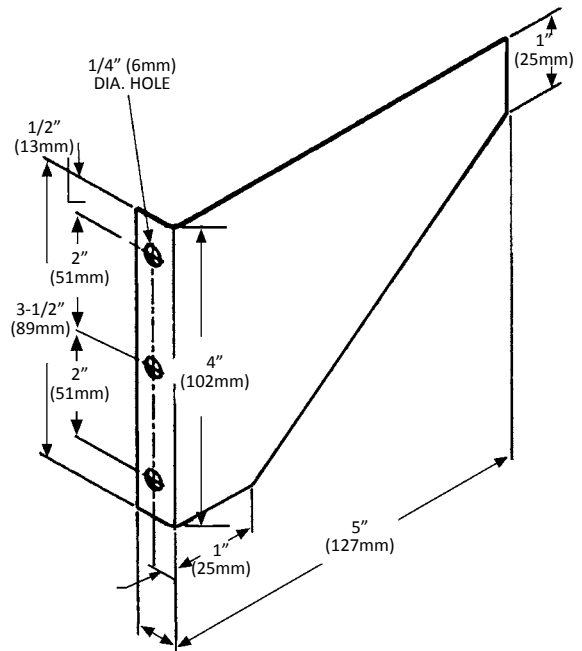

Bumpers & Grommets



BUMPERS & GROMMETS

RECESSED BUMPERS

FIG.	MODEL NO.	A	B	C	D	E	F
1	Q20-2081	5/8" (16mm)	5/16" (8mm)	3/16" (5mm)	1/8" (3mm)	1/4" (6mm)	3/16" (5mm)
2	Q20-2095	15/16" (24mm)	3/8" (10mm)	1/8" (3mm)	3/16" (5mm)	3/8" (10mm)	5/32" (4mm)

GROMMETS

FIG.	MODEL NO.	A	B	C	D	E
3	Q24-0220	9/16" (14mm)	1/4" (6mm)	1/4" (6mm)	1/16" (2mm)	3/8" (10mm)
3	Q24-0225	5/8" (16mm)	3/8" (10mm)	1/4" (6mm)	1/16" (2mm)	1/2" (13mm)
3	Q24-0230	13/16" (20mm)	1/2" (13mm)	9/32" (7mm)	1/16" (2mm)	5/8" (16mm)
4	Q24-0320	9/16" (14mm)	1/4" (6mm)	5/16" (8mm)	1/8" (3mm)	3/8" (10mm)

LARGE DIAMETER GROMMETS

FIG.	MODEL NO.	A	B	C	D	E
5	Q24-0420	1-7/8" (48mm)	1-1/8" (29mm)	3/8" (10mm)	1/16" (2mm)	1-1/2" (38mm)
5	Q24-0520	2-7/8" (75mm)	2-1/8" (54mm)	7/16" (11mm)	1/16" (2mm)	2-1/2" (64mm)

BUTTON BUMPERS

FIG.	MODEL NO.	A	B	C	D	E	F
6	Q26-3062	3/8" (10mm)	1/4" (6mm)	1/4" (6mm)	5/16" (8mm)	3/64" (1mm)	3/64" (1mm)
6	Q26-4071	1/2" (13mm)	3/8" (10mm)	3/16" (5mm)	1/8" (3mm)	1/16" (2mm)	1/16" (2mm)
7	Q26-4072	1/2" (13mm)	3/8" (10mm)	3/16" (5mm)	3/16" (5mm)	3/16" (5mm)	1/16" (2mm)

PRESSURE SENSITIVE BUMPERS

FIG.	MODEL NO.	HEIGHT	DIAMETER
8	Q21-5003	.20" (5mm)	.44" (11mm)
8	Q21-5017	.38" (10mm)	.75" (20mm)

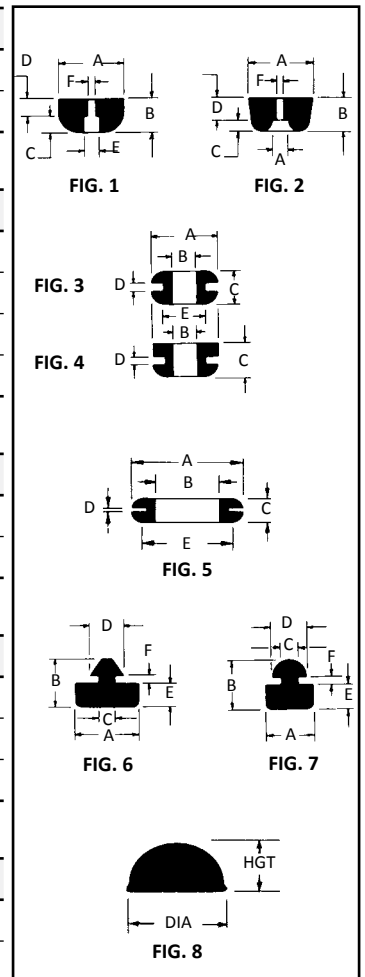



BALL BEARING SYSTEMS

BALL BEARING SYSTEMS...A COMPREHENSIVE GUIDE TO BEARING SELECTION SPECIFICALLY FOR FOOD SERVICE EQUIPMENT APPLICATIONS

COMPONENT HARDWARE HAS DESIGNED AN INNOVATIVE BALL BEARING SYSTEM WITH A DUAL FEATURE.

FIRST...A SYSTEM THAT SATISFIES THE OFTEN ENCOUNTERED PRICE AND DELIVERY PROBLEM WHEN PURCHASING EVEN STANDARD SIZE BEARINGS IN SMALL QUANTITIES. THIS SYSTEM PERMITS OFF THE SHELF DELIVERY AND SMART PRICES NO MATTER HOW SMALL THE ORDER QUANTITY.

SECOND...AND PERHAPS THE BEST...A BEARING SYSTEM THAT PERMITS THE USER TO CONFIGURE ESSENTIAL BEARING COMPONENTS TO ASSEMBLE A WIDE RANGE OF BEARING SIZES AND STYLES TO MEET INDIVIDUAL DESIGN REQUIREMENTS.

LISTED ON THIS PAGE IS A SELECTION OF BEARINGS, SCREW STUDS AND RIVETS WHICH ALLOWS YOU TO CHOOSE A BEARING ASSEMBLY TO SUIT YOUR SPECIFIC REQUIREMENTS.

INSTRUCTIONS: SELECT ANY BEARING WITH HOLE. IF SHOULDER IS REQUIRED CHOOSE SHOULDER SPACER(S) AS REQUIRED. SELECT THE RIVER OR SCREW STUD WITH LENGTH TO SATISFY SHOULDER, SHAFT CLEARANCE AND THICKNESS OF BEARINGS. (SEE ILLUSTRATION)

SELECTED BEARING

B20-1019	B20-1230
B20-1028	B20-1819
B20-1032	B23-1013
B20-1219	B24-1013

STAINLESS STEEL SCREW STUDS

MODEL NO.	TH'K
B30-X003	1" (25mm)
B30-X004	5/8" (16mm)
B30-X008	3/4" (19mm)

STAINLESS STEEL SHOULDER SPACERS

MODEL NO.	TH'K
B10-X004	7/32" (6mm)
B10-X008	3/32" (2mm)
B10-X009	1/32" (1mm)

STAINLESS STEEL RIVETS

MODEL NO.	TH'K
B10-X012	1/2" (13mm)
B10-X013	3/4" (19mm)

Flat Bearings

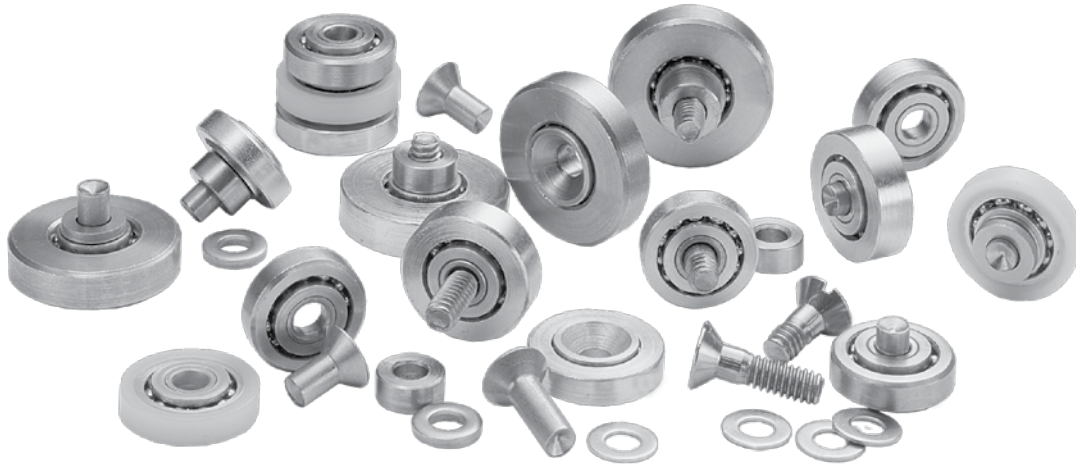

FLAT BEARINGS

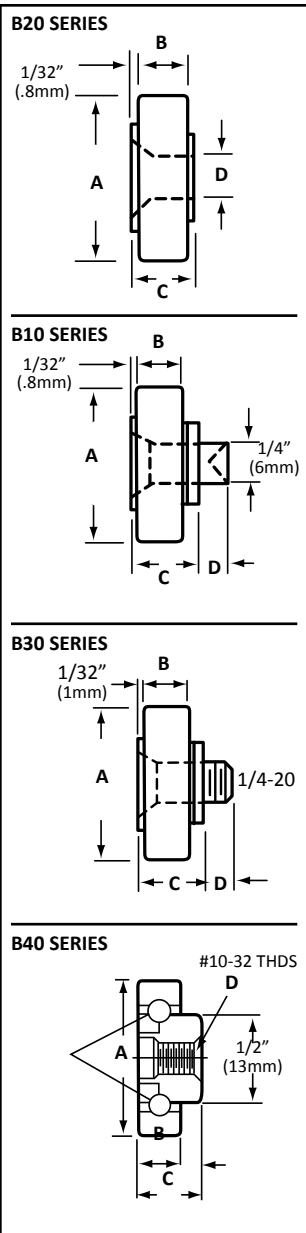

FLAT BEARINGS WITH HOLE

MODEL NO.	INNER RACE	OUTER RACE	A	B	C	D	LOAD*
B20-1013	STEEL	STEEL	7/8" (22mm)	7/32" (6mm)	9/32" (7mm)	1/4" (6mm)	42 lbs (19kg)
B20-1019	STEEL	STEEL	1" (25mm)	5/16" (8mm)	3/8" (10mm)	1/4" (6mm)	57 lbs (25kg)
B20-1032	STEEL	STEEL	1" (25mm)	7/32" (6mm)	9/32" (7mm)	1/4" (6mm)	57 lbs (25kg)
B20-1028	STEEL	STEEL	1-5/16" (33mm)	5/16" (8mm)	3/8" (10mm)	1/4" (6mm)	87 lbs (39kg)
B20-1819	STEEL	NYLON & STEEL	1" (25mm)	7/32" (6mm)	9/32" (7mm)	1/4" (6mm)	53 lbs (24kg)
B20-1230	STAINLESS ST'L	STAINLESS ST'L	29/32" (23mm)	1/4" (6mm)	5/16" (8mm)	1/4" (6mm)	90 lbs (40kg)
B20-1219	STAINLESS ST'L	STAINLESS ST'L	1-5/16" (33mm)	5/16" (8mm)	3/8" (10mm)	1/4" (6mm)	87 lbs (39kg)

FLAT BEARINGS WITH RIVET

B10-1013	STEEL	STEEL	7/8" (22mm)	7/32" (6mm)	3/8" (10mm)	1/8" (3mm)	42 lbs (19kg)
B10-1016	STEEL	STEEL	1" (25mm)	7/32" (6mm)	3/8" (10mm)	1/8" (3mm)	57 lbs (25kg)
B10-1025	STEEL	STEEL	1-5/16" (33mm)	5/16" (8mm)	3/8" (10mm)	3/32" (6mm)	87 lbs (39kg)
B10-1034	STEEL	STEEL	1-5/16" (33mm)	5/16" (8mm)	19/32" (15mm)	3/16" (5mm)	87 lbs (39kg)
B10-1822	STEEL	NYLON & STEEL	1" (25mm)	7/32" (6mm)	3/8" (10mm)	1/8" (3mm)	53 lbs (24kg)

FLAT BEARINGS WITH SCREW STUD

B30-1013	STEEL	STEEL	7/8" (22mm)	7/32" (6mm)	3/8" (10mm)	3/8" (10mm)	42 lbs (19kg)
B30-1210	STAINLESS ST'L	STAINLESS ST'L	29/32" (23mm)	1/4" (6mm)	11/32" (9mm)	5/16" (8mm)	90 lbs (40kg)
B30-1034	STEEL	STEEL	1-5/16" (33mm)	5/16" (8mm)	19/32" (15mm)	3/8" (10mm)	87 lbs (39kg)

FLAT BEARINGS WITH TAPPED HOLE

B40-1240	STAINLESS ST'L	STAINLESS ST'L	7/8" (22mm)	1/4" (6mm)	3/8" (10mm)	#10-32	80 lbs (35kg)
-----------------	----------------	----------------	----------------	---------------	----------------	--------	------------------

*BEARING LOAD RATINGS BASED ON 600 R.P.M.

Concave & Rubber Tire Bearings



CONCAVE & RUBBER TIRE BEARINGS

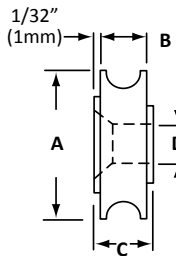

**CONCAVE BEARING WITH HOLE
STEEL INNER AND OUTER RACE**

MODEL NO.	A	B	C	D	LOAD*
B24-1013	1-3/16" (30mm)	5/16" (8mm)	3/8" (10mm)	1/4" (6mm)	80 lbs (36kg)

**RUBBER TIRE BEARING WITH HOLE
STEEL INNER AND OUTER RACE**

MODEL NO.	A	B	C	D	LOAD*
B23-1013	1-5/16" (33mm)	5/16" (8mm)	3/8" (10mm)	1/4" (6mm)	87 lbs (39kg)

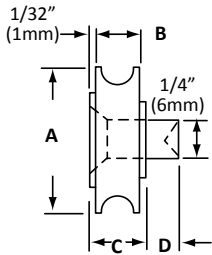
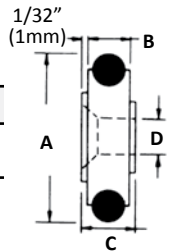

**CONCAVE BEARING WITH RIVET STUD
STEEL INNER AND OUTER RACE**

MODEL NO.	A	B	C	D	LOAD*
B14-1010	1-3/16" (30mm)	5/16" (8mm)	3/8" (10mm)	1/8" (3mm)	80 lbs (36kg)

**RUBBER TIRE BEARING WITH RIVET STUD
STEEL INNER AND OUTER RACE**

MODEL NO.	A	B	C	D	LOAD*
B13-1010	1-5/16" (33mm)	5/16" (8mm)	3/8" (10mm)	1/8" (3mm)	87 lbs (39kg)

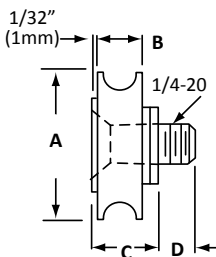
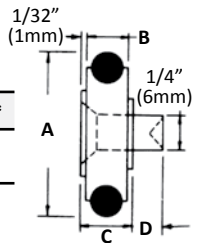

**CONCAVE BEARING WITH SCREW STUD
STEEL INNER AND OUTER RACE**

MODEL NO.	A	B	C	D	LOAD*
B34-1010	1-3/16" (30mm)	5/16" (8mm)	3/8" (10mm)	3/8" (10mm)	80 lbs (36kg)
B34-1016	1-3/16" (30mm)	5/16" (8mm)	19/32" (15mm)	1/8" (3mm)	80 lbs (36kg)

**RUBBER TIRE BEARING WITH SCREW STUD
STEEL INNER AND OUTER RACE**

MODEL NO.	A	B	C	D	LOAD*
B33-1010	1-5/16" (33mm)	5/16" (8mm)	3/8" (10mm)	3/8" (10mm)	87 lbs (39kg)
B33-1016	1-5/16" (33mm)	5/16" (8mm)	19/32" (15mm)	3/8" (10mm)	87 lbs (39kg)

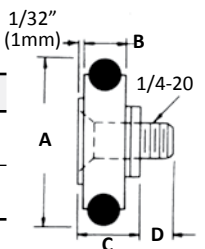

*May not be identical to competitors' products.

Ball Bearing Assemblies, Pulley & Wheels

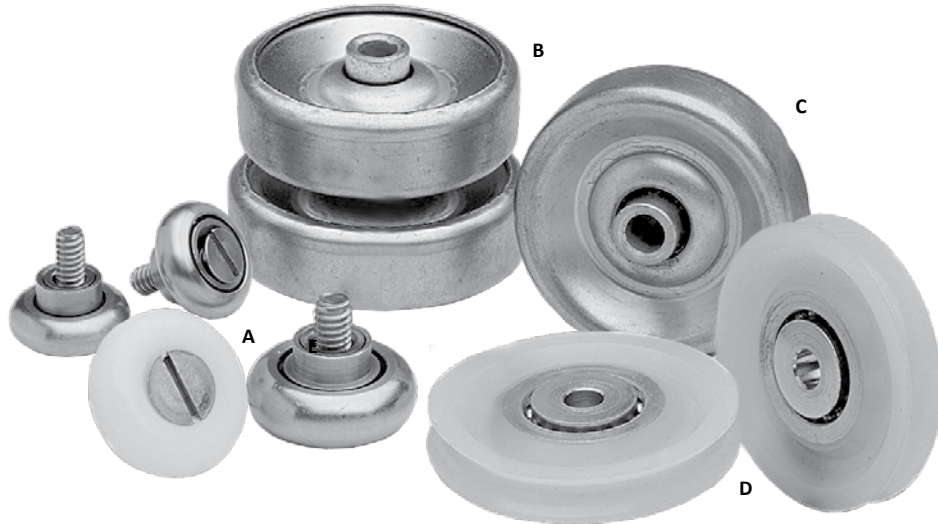

BALL BEARING ASSEMBLIES, PULLEY & WHEELS

REF A

DELRIN BEARING AND STAINLESS STEEL BALL BEARING ASSEMBLY WITH REMOVABLE THREADED FASTENER

MODEL NO.	MAT'L.	TYPE	A	B	C	D	E	F
S26-Y001	ST. ST'L	BALL B'R'G	.760 (19mm)	.250 (6mm)	.187 (5mm)	.420 (11mm)	.300 (8mm)	10-24
S10-Y001	Z.P. ST'L	BALL B'R'G	.760 (19mm)	.250 (6mm)	.187 (5mm)	.420 (11mm)	.300 (8mm)	10-24
S52-X101	DELIRIN	SOLID	1.070 (27mm)	.375 (10mm)	.187 (5mm)	.500 (13mm)	.260 (7mm)	1/4-20
S52-X001	ST. ST'L	BALL B'R'G	1.070 (27mm)	.375 (10mm)	.187 (5mm)	.500 (13mm)	.260 (7mm)	1/4-20

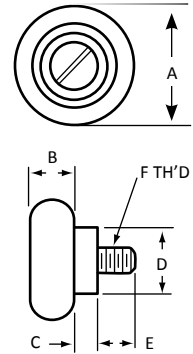

REF B

STAINLESS STEEL and STEEL WHEELS

- IDEAL FOR DRAWER SLIDES AND CONVEYOR ASSEMBLIES
- HEAT TREATED INNER AND OUTER RACEWAYS
- ALL METAL CONSTRUCTION

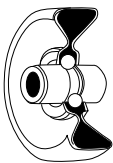

STAINLESS STEEL WHEEL
MODEL NO. IR-0031

STEEL WHEEL ZINC PLATED
MODEL NO. IR-2263

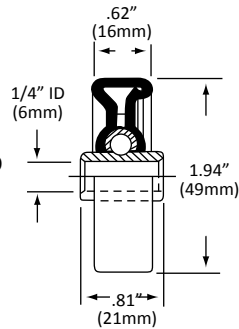

REF C

STAINLESS STEEL WHEEL

MODEL NO. IR-1061

ZINC PLATED STEEL
with OFFSET BUSHING
MODEL NO. IR-2112

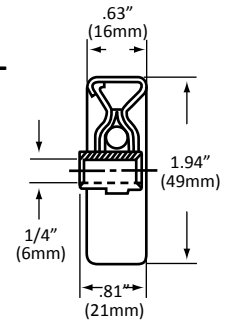
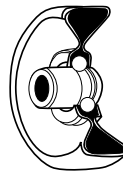

REF D

NYLON WHEEL PULLEY with STEEL RACES

NYLON/STEEL WHEEL PULLEY
MODEL NO. B25-1810

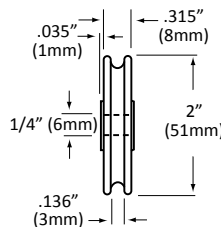
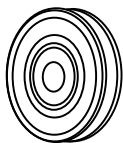



SLIDING DOOR COMPONENTS OVERHEAD TRACK COMPONENTS FOR SLIDING DOORS

REF A

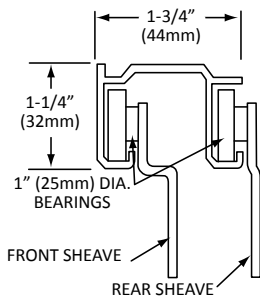

SLIDING DOOR TRACK EXTRUDED ALUMINUM 16 GAUGE

MODEL NO.	LENGTH
B57-0048	48" (1219mm)
B57-0060	60" (1524mm)
B57-0072	72" (1828mm)
B57-0120	120" (3048mm)
B57-0144	144" (3657mm)

REF B

FRONT DOOR SHEAVE, ZINC PLATED STEEL 3/4" (19mm) SIDE MOUNTED DOOR HANGER



MODEL NO.	WHEEL TYPE
B58-5511	FLAT, STEEL PLATED, BALL BEARING
B58-5513	FLAT, NYLON SURFACE, STEEL INNER RACES, BALL BEARING

REF C

REAR DOOR SHEAVE, ZINC PLATED STEEL 3/4" (19mm) SIDE MOUNTED DOOR HANGER

MODEL NO.	WHEEL TYPE
B58-5521	FLAT, STEEL PLATED, BALL BEARING
B58-5523	FLAT, NYLON SURFACE, STEEL INNER RACES, BALL BEARING

REF D

DOOR STOP

MATERIAL:
STEEL, ZINC PLATED

MODEL NO.
B60-1086

BUMPER:
SOLID RUBBER

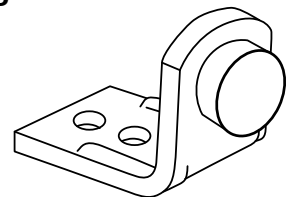

REF E

GUIDE PINS

MODEL NO. B56-1096

SPRING LOADED with PUSH-ON SPEED NUTS

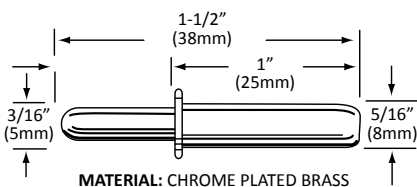

REF F

DOOR GUIDE

MODEL NO.
B62-1093

FOR 3/4" (19mm)
SLIDING DOORS

MATERIAL: NYLON
O.A. SIZE: 1-3/4" X 2-1/8"
(44mm x 54mm)

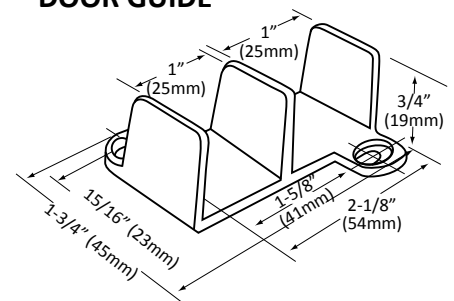

Index

MODEL NO.	PAGE NO.	MODEL NO.	PAGE NO.	MODEL NO.	PAGE NO.	MODEL NO.	PAGE NO.	MODEL NO.	PAGE NO.
B10-1013	G28	GBS15-1148-QP	G3	P30-4760	G13	Q26-4072	G26	S35-1018	G20
B10-1016	G28	GBS15-4112-Q	G3	P30-4761	G13	R74-8000-RH	G11	S35-1020	G20
B10-1025	G28	GBS15-4116-Q	G3	P30-4762	G13	R74-8001-LH	G11	S35-1022	G20
B10-1034	G28	GBS15-4118-Q	G3	P30-4770	G13	R74-8100-RH	G11	S35-1024	G20
B10-1822	G28	GBS15-4124-Q	G3	P30-4771	G13	R74-8101-LH	G11	S35-1026	G20
B10-X004	G27	GBS15-4130-Q	G3	P30-4772	G13	R74-9000-RH	G11	S52-0020	G17
B10-X008	G27	GBS15-413030Q	G3	P30-4780	G13	R74-9001-LH	G11	S52-0022	G17
B10-X009	G27	GBS15-4132-Q	G3	P30-4781	G13	R75-6661	G12	S52-0024	G17
B10-X012	G27	GBS15-4136-Q	G3	P40-1010	G5	R75-6662	G12	S52-0026	G17
B10-X013	G27	GBS15-414030Q	G3	P44-1010	G6	R76-1000	G12	S52-2020	G17
B13-1010	G29	GBS15-4142-Q	G3	P45-3000	G6	S10-0014	G18	S52-2022	G17
B14-1010	G29	GBS15-4148-Q	G3	P45-3500	G6	S10-0016	G18	S52-2024	G17
B20-1013	G27, G28	IR-0031	G30	P45-4000	G6	S10-0018	G18	S52-2026	G17
B20-1019	G27, G28	IR-1061	G30	P46-1010	G6	S10-0020	G18	S52-X001	G17, G30
B20-1028	G27, G28	IR-2112	G30	P46-1012	G6	S10-0022	G18	S52-X101	G17, G30
B20-1032	G27, G28	IR-2263	G30	P47-1012	G5	S10-0024	G18	S80-1520	G22
B20-1219	G27, G28	J85-1000	G25	P47-1018	G5	S10-0026	G18	S80-2020	G22
B20-1230	G27, G28	J85-2000	G25	P48-1010	G4	S10-Y001	G18, G30,	S81-1520-C	G22
B20-1819	G27, G28	M10-8332	G9	P48-1012	G4	S15-1012	G20	S81-2020-C	G22
B23-1013	G27, G29	M10-8333	G9	P48-X002	G4	S15-1014	G20	S90-0015	G23
B24-1013	G27, G29	M11-8201	G9	P49-1010	G5	S15-1016	G20	S90-0015-C-N	G23
B25-1810	G30	M12-9293	G12	P49-1500	G4	S15-1018	G20	S90-0015-N	G23
B30-1013	G28	M12-9294	G12	P49-1500-6	G4	S15-1020	G20	S90-0020	G23
B30-1034	G28	M12-9295	G12	P49-2100	G5	S15-1022	G20	S90-0020-C-N	G23
B30-1210	G28	M15-9210	G10	P49-2200	G5	S15-1024	G20	S90-0020-N	G23
B30-X003	G27	M15-9211	G10	P50-1010	G6	S15-1026	G20	S90-X030	G23
B30-X004	G27	M20-2590	G16	P50-1011	G6	S25-0012	G19	S90-X032	G23
B30-X008	G27	M21-2580	G16	P50-5000	G7	S25-0014	G19	S90-X033	G23
B33-1010	G29	M22-2420	G16	P51-1010	G6	S25-0016	G19	SE90-0015	G23
B33-1016	G29	M22-2430	G16	P51-1024	G6	S25-0018	G19	SE90-0015-C-N	G23
B34-1010	G29	M24-2260	G16	P52-1010	G6	S25-0020	G19	SE90-0015-N	G23
B34-1016	G29	M25-9469	G16	P53-1012	G6	S25-0022	G19	SE90-0020	G23
B40-1240	G28	M27-2490	G16	P60-1010	G7	S25-0024	G19	SE90-0020-C-N	G23
B56-1096	G31	M30-2400	G15	P62-1010	G7	S25-0026	G19	SE90-0020-N	G23
B57-0048	G31	M30-5920	G15	P62-1014	G7	S25-0028	G19	S95-1000	G24
B57-0060	G31	M32-2401	G15	P63-1012	G7	S25-2012	G19	S95-Y001	G24
B57-0072	G31	M35-1000	G15	P68-1010	G9	S25-2014	G19	S95-Y001-KEY	G24
B57-0120	G31	M35-2000	G15	P70-1010	G9	S25-2016	G19	S95-Y002	G24
B57-0144	G31	M36-0201	G15	P73-1000	G7	S25-2020	G19	S95-Y002-KEY	G24
B58-5511	G31	M36-0611	G15	P73-2000	G7	S25-2022	G19	SG-101	G2
B58-5513	G31	M36-0801	G15	P75-1000-Q	G2	S25-2024	G19	W37-3000-SS	G11
B58-5521	G31	M48-0112	G10	P75-4000	G2	S25-2026	G19		
B58-5523	G31	M48-0121	G10	P75-5000	G2	S25-2028	G19		
B60-1086	G31	M48-0122	G10	P80-3000	G5	S26-0014	G18		
B62-1093	G31	M48-0131	G10	P80-3020	G5	S26-0016	G18		
CD-1000	G24	M48-0132	G10	P80-3030	G5	S26-0018	G18		
CD-Y004	G24	M48-0134	G10	P88-1010	G9	S26-0020	G18		
GBS15-1112-Q	G3	M48-0142	G10	P90-1000	G8	S26-0022	G18		
GBS15-1112-QP	G3	M48-0143	G10	P90-2000	G8	S26-0026	G18		
GBS15-1116-Q	G3	M48-0144	G10	P90-2000-C	G8	S26-Y001	G18, G30		
GBS15-1116-QP	G3	M48-0154	G10	P90-5000	G8	S30-1018	G21		
GBS15-1118-Q	G3	M74-2078	G12	P90-5000-C	G8	S30-1020	G21		
GBS15-1118-QP	G3	M74-3078	G12	P91-5000	G8	S30-1022	G21		
GBS15-1124-Q	G3	M75-1002	G11	Q20-2081	G26	S30-1024	G21		
GBS15-1124-QP	G3	M75-5003	G11	Q20-2095	G26	S30-2018	G21		
GBS15-1130-Q	G3	M80-2500	G9	Q21-5003	G26	S30-2020	G21		
GBS15-1130-QP	G3	P10-0370	G14	Q21-5017	G26	S30-2022	G21		
GBS15-113030Q	G3	P11-0480	G14	Q24-0220	G26	S30-2024	G21		
GBS15-1132-Q	G3	P20-0490	G14	Q24-0225	G26	S30-3018	G21		
GBS15-1132-QP	G3	P22-0006	G14	Q24-0230	G26	S30-3020	G21		
GBS15-1136-Q	G3	P30-0802	G13	Q24-0320	G26	S30-3022	G21		
GBS15-1136-QP	G3	P30-1000	G13	Q24-0420	G26	S30-3024	G21		
GBS15-1142-Q	G3	P30-4750	G13	Q24-0520	G26	S30-Y001	G21		
GBS15-1142-QP	G3	P30-4751	G13	Q26-3062	G26	S30-Y002	G21		
GBS15-1148-Q	G3	P30-4752	G13	Q26-4071	G26	S35-1016	G20		



COMPONENT
HARDWARE

1890 Swarthmore Avenue • PO Box 2020 • Lakewood • NJ 08701
Tel. 800-526-3694 • 732-363-4700 • Fax 732-364-8110
www.componenthardware.com

