

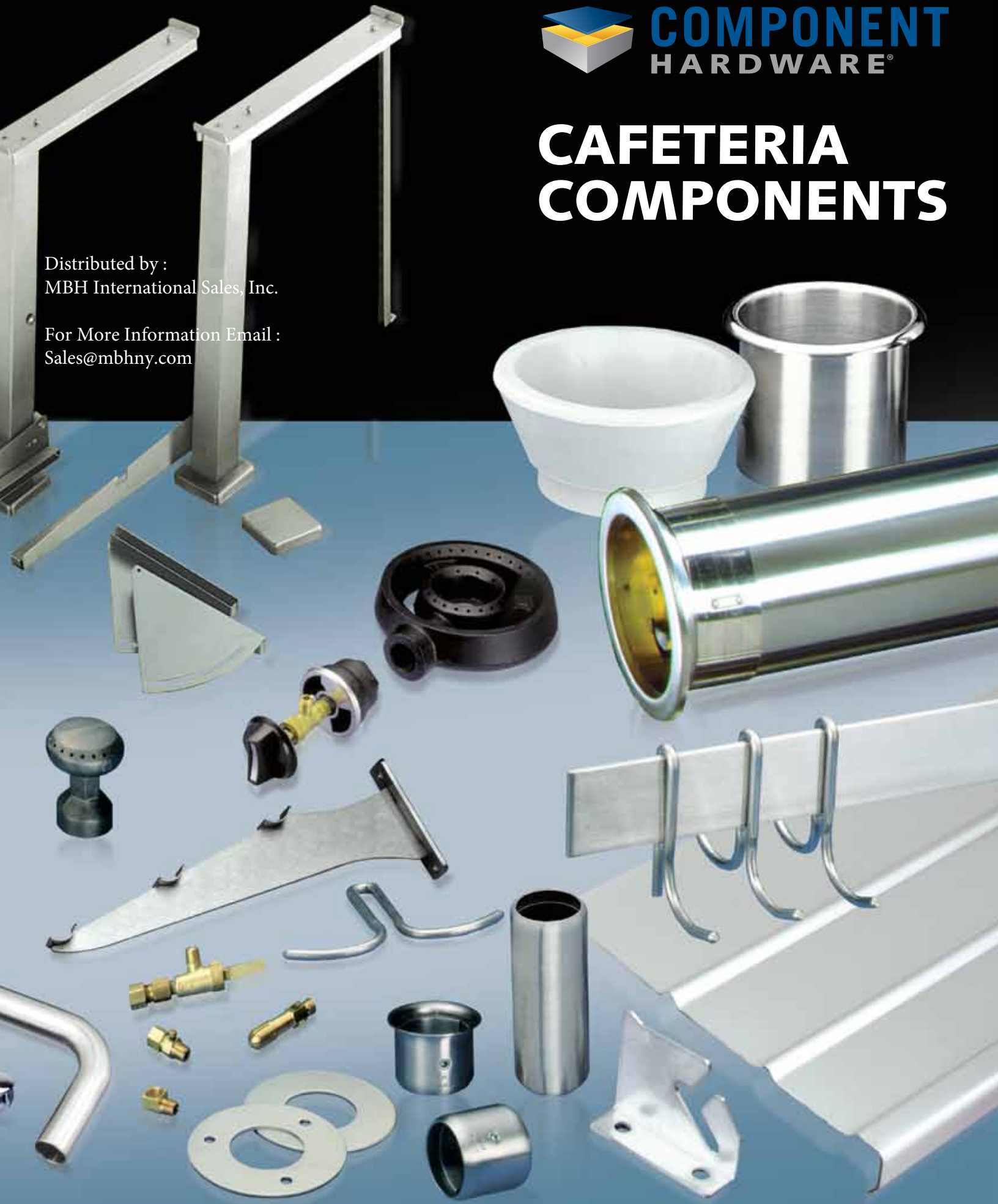

CAFETERIA COMPONENTS

Distributed by :
MBH International Sales, Inc.

For More Information Email :
Sales@mbhny.com



Member Organizations

Component Hardware Group is a proud member of the following organizations



Products shown in this catalog may be listed and/or certified by one or more of the following regulatory agencies and will be designated by the following marks



All photographs and illustrations are considered to be a representation of the actual item. In some cases there may be slight variations. This catalog, copy, part numbers and unique method of illustrating products is copyrighted by Component Hardware Group, Inc. All rights reserved. No portion of this catalog may be reproduced in any form or by any means in whole or in part, without the written consent of Component Hardware. Component Hardware reserves the right to make any and all changes and to discontinue any of its products without notice.

Not responsible for typographical errors.

*May not be identical to competitors' products.

DESCRIPTION	PAGE	DESCRIPTION	PAGE
A		H	
AIR MIXING PLATES	F20	HOLE PLUGS	F13
AIR MIXING VALVES	F20	HOOKS, POT RACK	F9
B		I	
BOTTLE OPENER	F14	ICE SCOOP/BRACKET	F14
BRACKETS		INSERTS, CORNER	F15
3 RAIL	F3, F4	K	
FIXED	F3	KNURLED TUBING INSERTS	F10
FOLD DOWN	F4	L	
LID COVER	F13	LID COVER BRACKET ASSEMBLY	F13
PROTECTOR	F3	LIQUID WASTE DUMP	F14
REMOVABLE	F4	M	
SNEEZE GUARD	F5	MOULDINGS	F8
TRAY SLIDE	F2, F3	O	
BRITE GARD CLEANING PRODUCTS		ORIFICE, GAS BURNER	F20
ALL PURPOSE WIPERS	F16	ORDER FORM, CONVEYOR ROLLER	F18
STAINLESS STEEL CLEANER	F16	P	
BURNERS		POT HOOKS	F9
LOOP	F19	POT RACK COMPONENTS	F9
MUSHROOM	F19	PROTECTOR ASSEMBLY	F5
RING	F19	R	
BUSHINGS, KNURLED	F12	RINGS, FINISHING	F14
BURNER COMPONENTS	F20	ROLLER ASSEMBLIES	F17
C		ROLLER COMPONENTS	F17
CAP STRIPS	F7	S	
CHANNEL, DOUBLE	F6	SCRAP BLOCKS	F14
CLAMP, GLASS FOR ROUND TUBING	F6	SCRAP CHUTES	F14
CONVEYOR ROLLER ASSEMBLIES	F17	SINK CORNER INSERTS	F15
CONVEYOR ROLLER COMPONENTS	F17	SNEEZE GUARD COMPONENTS	F5
CUP DISPENSERS	F11	SUPPORTS, TUBULAR	F9, F10
D		T	
DIPPERWELL	F14	TRAY SLIDE COMPONENTS	F2
DIVIDER BAR	F7, F8	TRAY SLIDES	F2, F3
DRIP PLATES	F12	TUBING COMPONENTS	F9, F10
E		U	
ELBOWS, TUBULAR	F2, F10	U-BENDS, TUBULAR	F2
END CAPS, TUBING	F2, F13	V	
ESCUTCHEON PLATE	F10	VALVES, BURNER	F20
EXPANDING FASTENERS, TUBING	F10	W	
F		WHEELS	F17
FASTENERS, EXPANDING	F10		
FINISHING RING, DRIP PLATE	F12		
FLANGES, TUBING	F10		
G			
GAS BURNER COMPONENTS	F20		
GAS BURNERS	F19, F20		
GLASS CAPPINGS	F6		
GLASS CLAMP FOR ROUND TUBING	F6		

Tray Slide Components

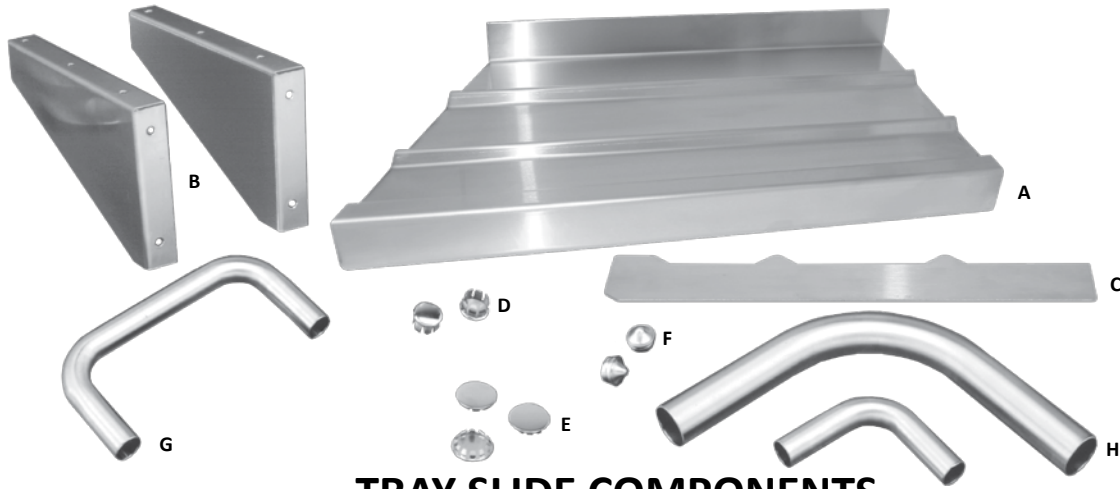

TRAY SLIDE COMPONENTS

- REF. A** STAINLESS STEEL • ROLL FORMED
CONTINUOUS TRAY SLIDE
- PROVIDED WITH 90° ANGLE FOR EASY INSTALLATION
 - CONTINUOUS...PERFECT ALIGNMENT • SATIN POLISHED FINISH

MODEL NO.	GAUGE	LENGTH	PKG.
J12-1601	16 ga (1.6mm)	10 ft (3000mm)	2/CTN

NOTE: OTHER LENGTHS AVAILABLE ON APPLICATION WITH QUANTITY ORDERS

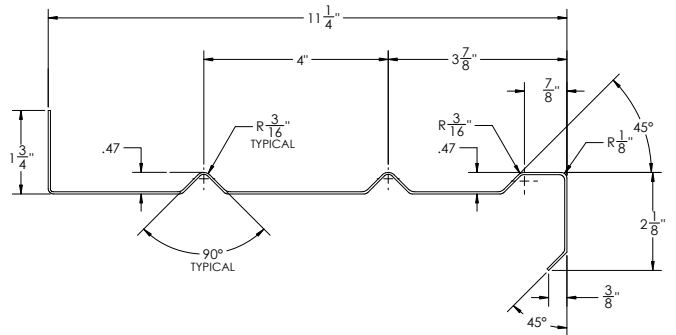

- REF. B** HEAVY 14 GAUGE
STAINLESS STEEL BRACKET
MODEL NO. J19-1400
- ECONOMICAL
 - POLISHED TO A #4 SATIN FINISH
 - PROVIDED WITH 91° ANGLE TO PREVENT TRAY SLIDE SAG
 - PRE-DRILLED MOUNTING HOLES FOR FAST CONVENIENT INSTALLATION
 - IDEAL FOR USE WITH CONTINUOUS TRAY SLIDE

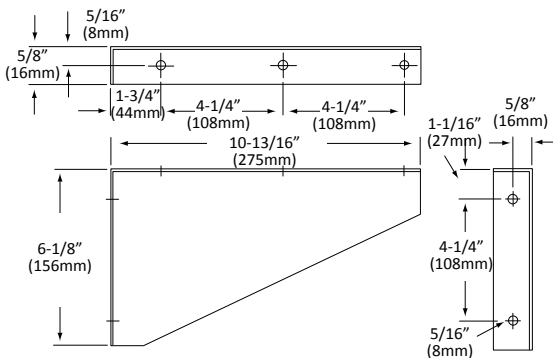

- REF. C** STAINLESS STEEL
END PLATE
MODEL NO. J12-1402
 14 ga (1.9mm) POLISHED
 STAINLESS STEEL FINISH

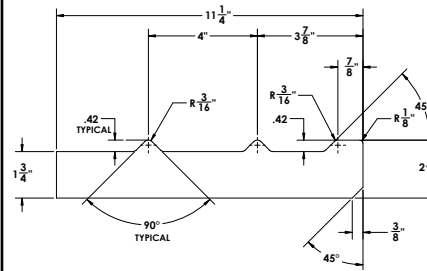

- REF. D** NICKEL PLATED STEEL
END CAP
 FOR 1" (25mm)
 O.D. TUBING
MODEL NO. J16-0201

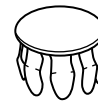

- REF. E** NICKEL PLATED STEEL
END CAP
 FOR 1-5/8" (41mm) O.D. TUBING
MODEL NO. J16-0158

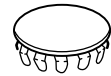

- REF. F** SOLID STAINLESS STEEL
END CAP
 FOR 1" (25mm) O.D.
 18 ga (1.2mm) TUBING
 (WELD APPLICATION)
MODEL NO. J16-0100

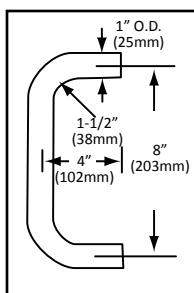

- REF. G** 16 GAUGE (1.5 mm) STAINLESS STEEL
"U" BENDS
 FOR 1" (25mm) O.D. TUBING
 DESIGNED FOR TRAY SLIDE RAILS
MODEL NO. J13-4488*
 *CAN BE USED WITH NO.'S
J19-4960 & J19-4955
 3 RAIL TRAY SLIDE BRACKETS

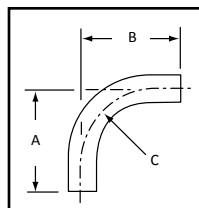

- REF. H** STAINLESS STEEL
90° ELBOWS
- 16 ga (1.5mm) • FOR 1" (25mm) & 1-5/8" (41mm) TUBING DESIGNED FOR RAILS, SUPPORTS, ETC.

MODEL NO.	O.D.	A	B	C
J14-0117	1" (25mm)	4" (102mm)	4" (102mm)	1-1/2" (38mm)
J14-0119	1-5/8" (41mm)	10" (254mm)	10" (254mm)	4-5/8" (117mm)



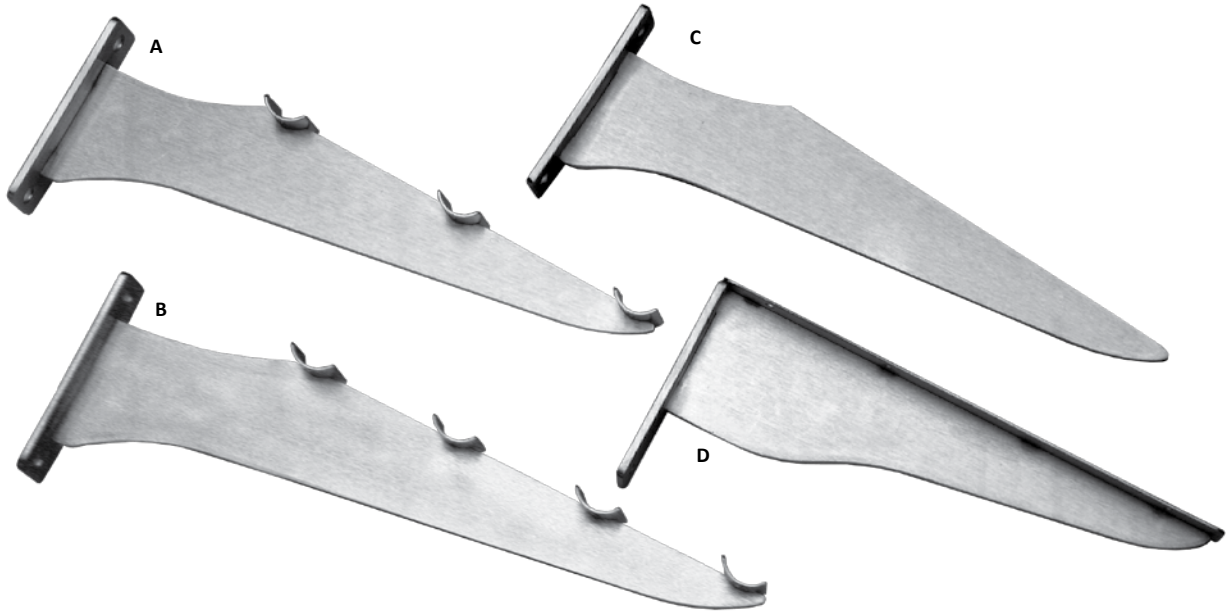

TRAY SLIDE and SHELF BRACKETS

REF. A

STAINLESS STEEL 3-RAIL TRAY SLIDE BRACKET

LOAD CAPACITY: 200 lbs PER 2 BRACKETS

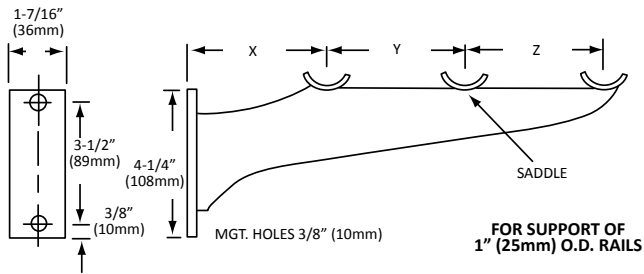

FOR SUPPORT OF
1" (25mm) O.D. RAILS

MODEL NO.	"X"	"Y"	"Z"
J19-4960	4" (102mm)	4" (102mm)	4" (102mm)
J19-4962	4" (102mm)	4-1/2" (114mm)	4-1/2" (114mm)

REF. C

STAINLESS STEEL TRAY SLIDE BRACKET WITHOUT SADDLES

MODEL NO. J19-4960-LT

LOAD CAPACITY: 150 lbs PER 2 BRACKETS

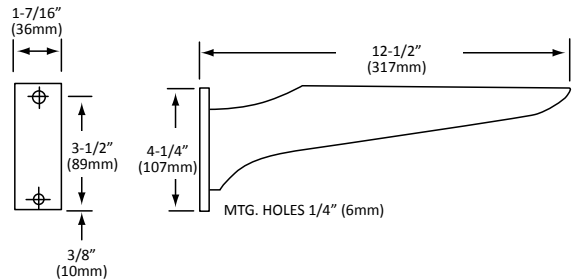

REF. B

STAINLESS STEEL 4-RAIL TRAY SLIDE BRACKET

MODEL NO. J19-4964

LOAD CAPACITY: 200 lbs PER 2 BRACKETS

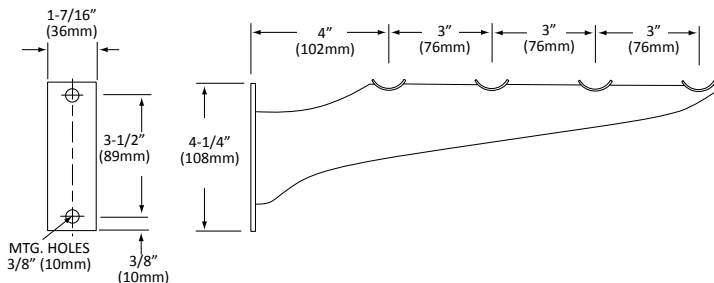

REF. D

STAINLESS STEEL FIXED SHELF BRACKET

MODEL NO. J19-4966

LOAD CAPACITY: 200 lbs PER 2 BRACKETS

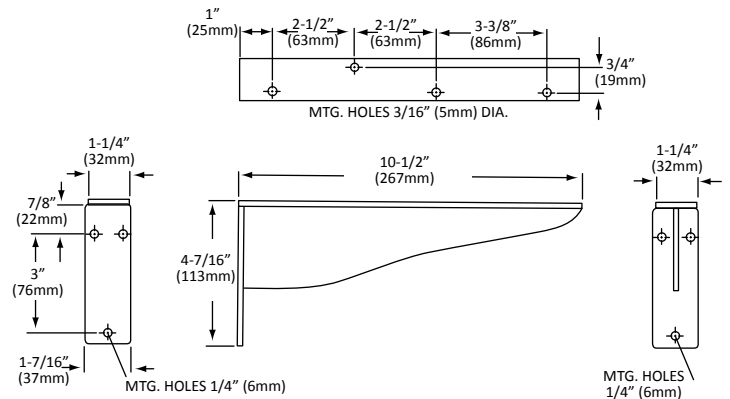

ALL BRACKETS SHOWN ARE 8 GAUGE (.170" - 4.5mm), STAINLESS STEEL POLISHED TO A #4 SATIN FINISH

Fold Down / Removable Shelf Brackets

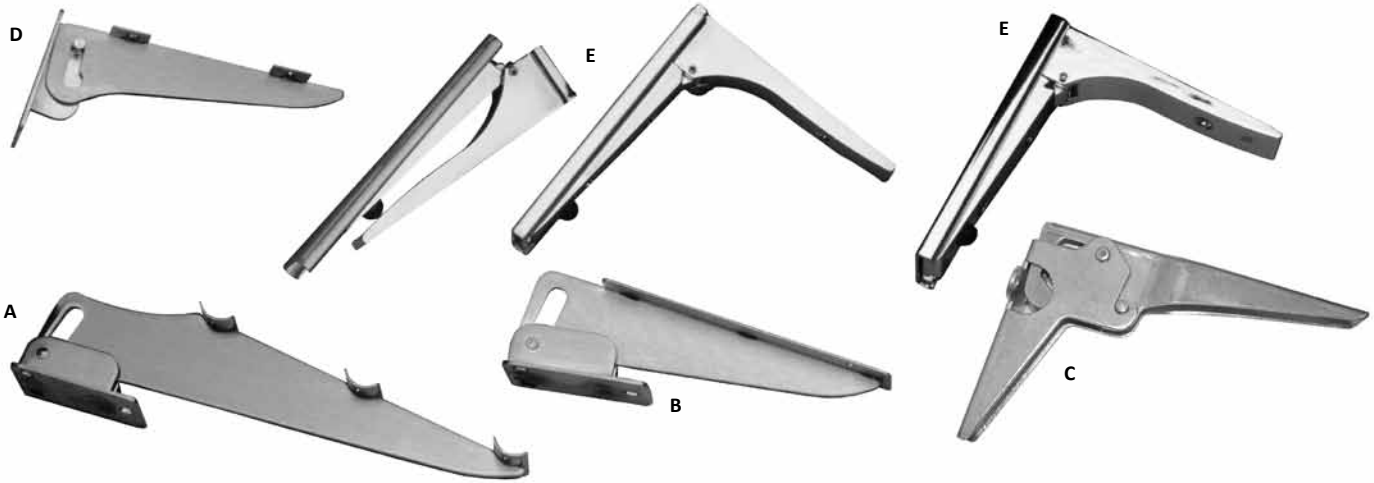

FOLD DOWN / REMOVABLE SHELF BRACKETS

REF. A STAINLESS STEEL FOLD DOWN 3-RAIL TRAY SLIDE BRACKET MODEL NO. J19-4955

LOAD CAPACITY: 150 lbs PER 2 BRACKETS
FOR SUPPORT OF 1" (25mm) O.D. RAILS
ALSO AVAILABLE WITHOUT SADDLES... ORDER AS J19-4955-LT

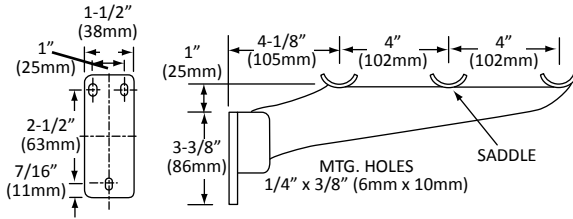

REF. B STAINLESS STEEL FOLD DOWN SHELF BRACKET MODEL NO. J19-4967

LOAD CAPACITY: 200 lbs PER 2 BRACKETS

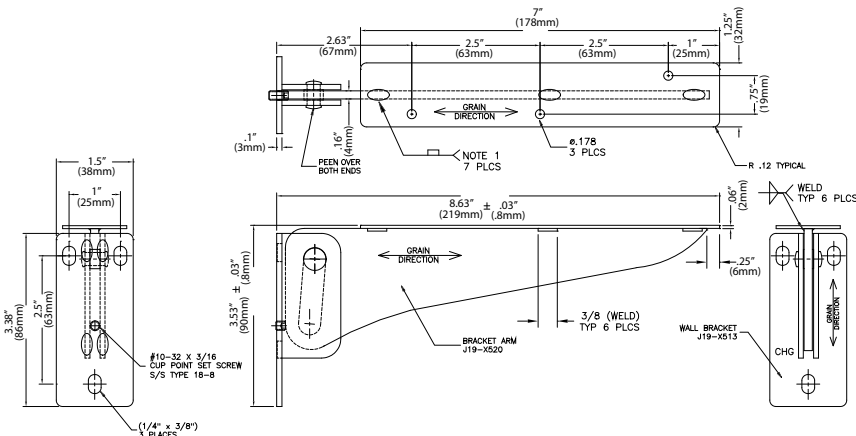

REF. D STAINLESS STEEL FOLD DOWN REMOVABLE SHELF BRACKET



• SATIN FINISH • HEAVY DUTY
MODEL NO. J19-5000*

*SOLD AS A PAIR, KEYHOLE BASE WITH BRACKET
AND STRAIGHT PIN BASE WITH BRACKET
MATERIAL: STAINLESS STEEL WITH A #4 FINISH
LOAD CAPACITY: 150 lbs PER 2 BRACKETS

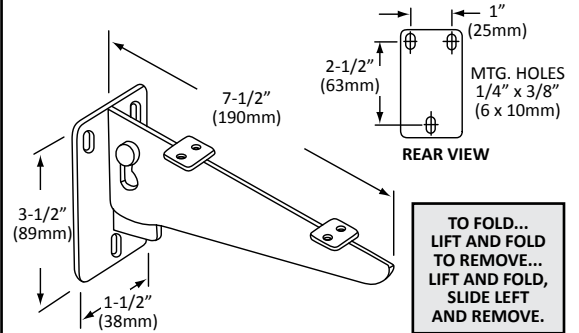

REF. E HEAVY DUTY FOLDING REMOVABLE SHELF BRACKET

• FOLDS DOWN WHEN NOT IN USE
• SHELVES EASILY REMOVED FOR CLEANING

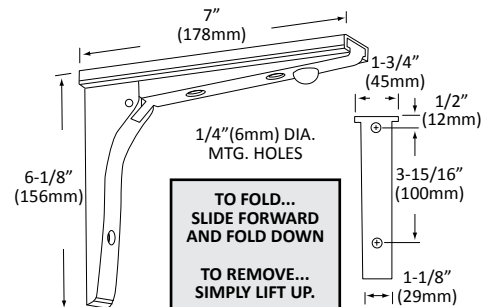

REF. C HEAVY DUTY ZINC PLATED STEEL FOLD DOWN SHELF BRACKET MODEL NO. J18-2000

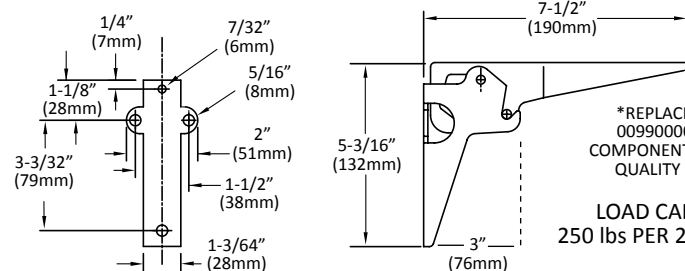

MODEL NO.	DESCRIPTION
J17-4270	CHROME PLATED DIE CAST BRACKET with 14 ga (2mm) ZINC PLATE STEEL MOUNT
J17-4273	CHROME PLATED DIE CAST BRACKET with 300 SERIES STAINLESS STEEL MOUNT

LOAD CAPACITY: 200 lbs PER 2 BRACKETS

Protector And Sneeze Guard Components



PROTECTOR AND SNEEZE GUARD COMPONENTS

STAINLESS STEEL PROTECTOR ASSEMBLY

- STAINLESS STEEL CONSTRUCTION
- FOLD DOWN BRACKET DESIGN
- RIGID SUPPORT POST
- STURDY BASES

SPECIFICATIONS:

STOCK SIZE: 14" (357mm) HIGH, 10" (254mm) SHELF, 10° SLANT FRONT

POSTS: SEAMLESS STAINLESS STEEL

BRACKETS: STAINLESS STEEL
DIE FORMED FURNISHED WITH LOCKING FEATURE TO HOLD BRACKET ASSEMBLY IN CLOSED POSITION ...NYLON ROLLER AND END CHANNEL TO ACCEPT WRAPPED GLASS FOR NOMINAL 1/4" (6mm) GLASS

MOUNTING: 5/16" x 2-1/4" (8mm x 57mm) BOLT FURNISHED FOR FASTENING FROM UNDERSIDE

STAINLESS STEEL PROTECTOR ASSEMBLY WITH FOLD DOWN BRACKETS

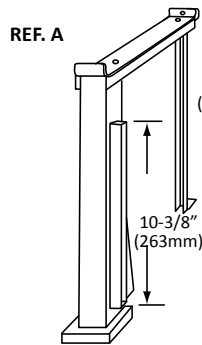

MODEL NO. J25-2100
(LEFT HAND)

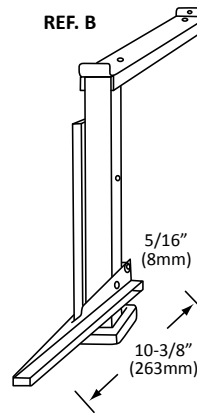

MODEL NO. J25-2300
(CENTER)

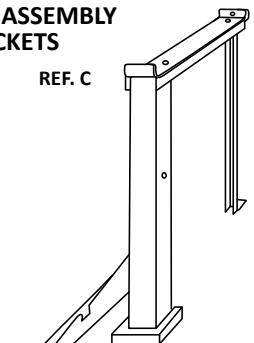

MODEL NO. J25-2200
(RIGHT HAND)



STAINLESS STEEL SNEEZE GUARD BRACKETS

MODEL NO. J30-4465

INCLUDES PAIR OF BRACKETS...
(1) RIGHT HAND & (1) LEFT HAND WITH
(2) THUMBSCREWS FOR ADJUSTMENT

SPECIFICATIONS:
SHOE PROVIDED TO ACCEPT
WRAPPED 1/4" (6mm) PLATE GLASS

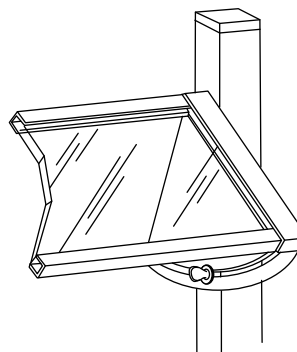
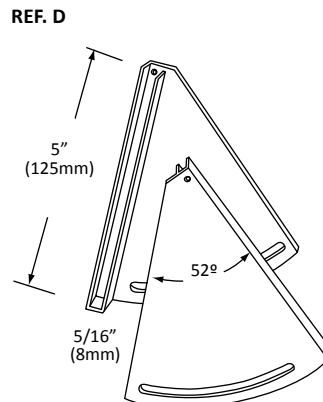

REF. E

STAINLESS STEEL PROTECTOR BRACKETS

MODEL NO. J29-4482

10-3/8" (263mm)
LG. BRACKETS, 1-- PAIR

Glass Clamps, Glass Capping And Channel

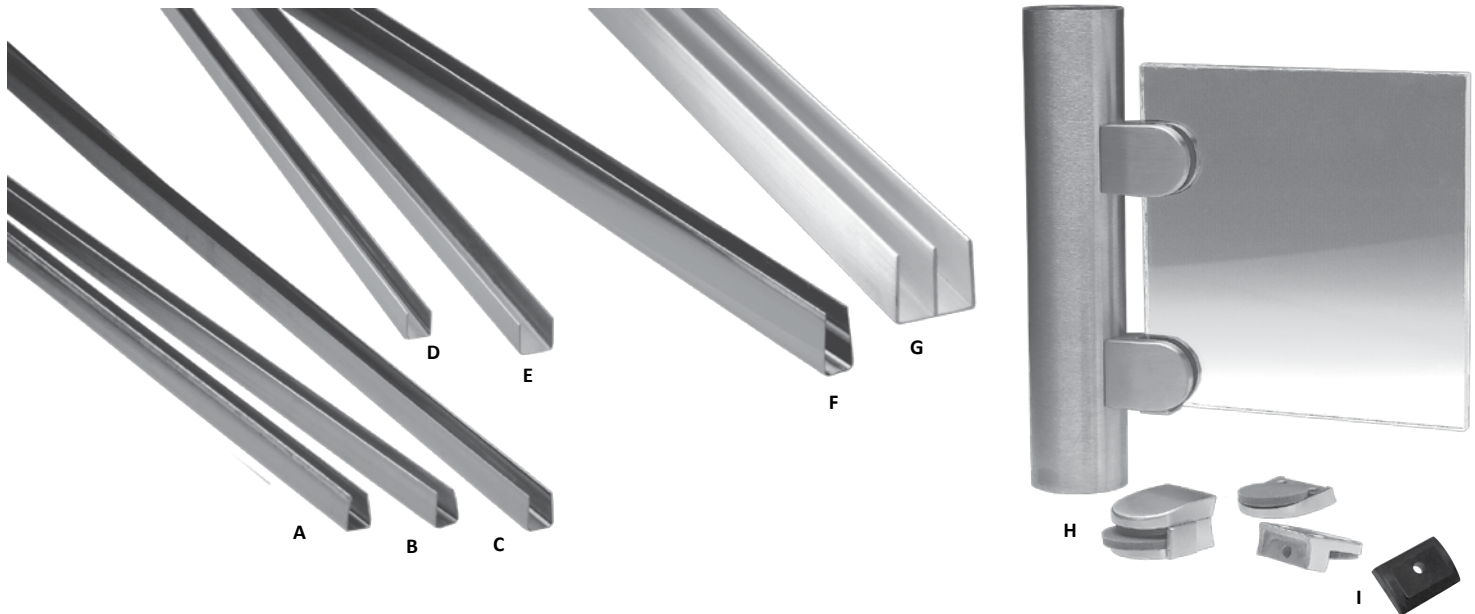

GLASS CLAMPS, GLASS CAPPING AND CHANNEL

STAINLESS STEEL GLASS CAPPING

- PREVENTS CHIPPING • PROVIDES SECURE FIT
- ATTRACTIVE POLISHED FINISH

REF.	MODEL NO.	STAINLESS STEEL TYPE	GAUGE
A	B70-1001	300 SERIES	.022 (.6mm)
B	B70-1002	300 SERIES	.022 (.6mm)
C	B70-1003	300 SERIES	.022 (.6mm)
D	B70-1005	400 SERIES	.019 (.5mm)
E	B70-1007	400 SERIES	.019 (.5mm)
F	B70-1008	400 SERIES	.019 (.5mm)
A	*B70-1001-6	300 SERIES	.022 (.6mm)

*6 ft (1.9m) LENGTH.
STOCK LENGTH 12 ft (3.6m) MINIMUM ORDER 144 ft (43.9m)

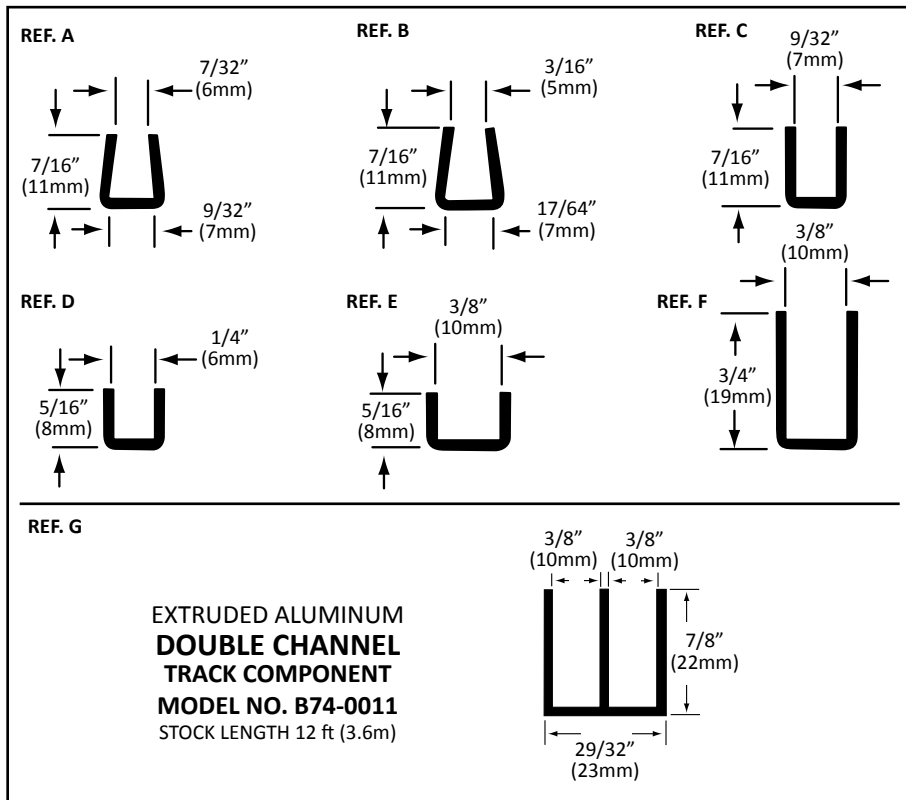

REF. H STAINLESS STEEL GLASS CLAMP FOR ROUND TUBING

MODEL NO. B79-1000 1/4" GLASS CLAMP, TOP	MODEL NO. B79-2000-L 1/4" GLASS CLAMP, BOTTOM LEFT	MODEL NO. B79-2000-R 1/4" GLASS CLAMP, BOTTOM RIGHT
MODEL NO. B79-1038 3/8" GLASS CLAMP, TOP	MODEL NO. B79-2038-L 3/8" GLASS CLAMP, BOTTOM LEFT	MODEL NO. B79-2038-R 3/8" GLASS CLAMP, BOTTOM RIGHT

NOTE: MOUNTING SCREW NOT PROVIDED

- FIRMLY HOLDS GLASS WITHOUT DRILLING
- UNIQUE LEDGE ON BOTTOM BRACKETS PROVIDES A POSITIVE STOP TO MAKE INSTALLATION EASIER
- LIGHT GRAY SILICONE PAD CUSHIONS GLASS, WHILE PROVIDING MAXIMUM GRIPPING POWER
- SLEEK DESIGN MAXIMIZES VIEWABLE SURFACE AREA OF GLASS
- 3/8" OFFSET
- FOR USE WITH 1-5/8" TUBING
- IDEAL FOR PARTITIONS, DISPLAYS AND SNEEZE GUARDS
- SATIN FINISH MATCHES COUNTERTOPS AND SUPPORTS

REF. I
BLACK DELRIN ADAPTER FOR SQUARE TUBING APPLICATION 1/4" GLASS ONLY

MODEL NO. B79-X014

Cap Strips And Divider Bars

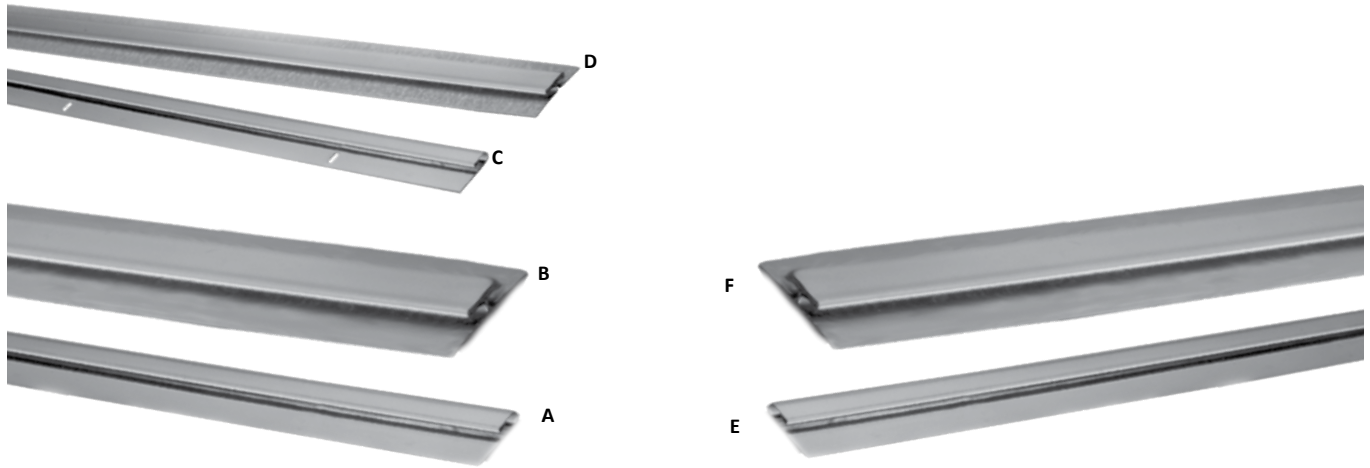

CAP STRIP AND DIVIDER BAR

- NEW EXTRA WIDE PROFILE FOR EASIER INSTALLATION • ALL STAINLESS STEEL CONSTRUCTION • ACCEPTS 1/16" (2mm) WALL FLASHING MATERIAL • GRAIN OF FINISH MATCHES WALL LINING • AVAILABLE IN VARIOUS LENGTHS TO MINIMIZE SCRAP • INDIVIDUALLY PLASTIC SLEEVED FOR PROTECTION OF FINISH • CAP STRIP HAS HEMMED EDGE FOR SAFETY

REF. A
EXTENDED WIDE STAINLESS STEEL CAP STRIP
 FOR 1/16" (1.6mm) MATERIAL
SATIN FINISH
MODEL NO. J63-1651-78
 6-1/2 ft (2m) LENGTH
MODEL NO. J63-1651-120
 10 ft (3m) LENGTH

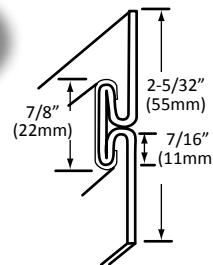
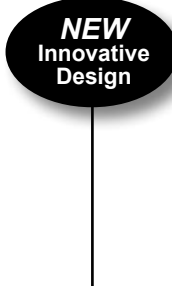
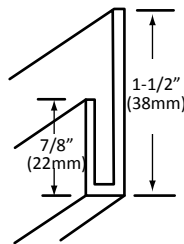

REF. B
EXTENDED WIDE STAINLESS STEEL DIVIDER BAR WITH S/S BACK PLATE
 FOR 1/16" (1.6mm) MATERIAL
SATIN FINISH
MODEL NO. J64-1651-78
 6-1/2 ft (2m) LENGTH
MODEL NO. J64-1651-120
 10 ft (3m) LENGTH

- ALL STAINLESS STEEL CONSTRUCTION • ACCEPTS 1/16" (2mm) WALL FLASHING MATERIAL • GRAIN OF FINISH MATCHES WALL LINING • AVAILABLE IN VARIOUS LENGTHS TO MINIMIZE SCRAP • INDIVIDUALLY PLASTIC SLEEVED FOR PROTECTION OF FINISH

REF. C
STAINLESS STEEL CAP STRIP
 FOR 1/16" (1.6mm) MATERIAL
#4 SATIN FINISH
MODEL NO. J63-1451
 7 ft (2.1m) LENGTH
MODEL NO. J63-1451-8*
 8 ft (2.4m) LENGTH
MODEL NO. J63-1451-9*
 9 ft (2.7m) LENGTH
MODEL NO. J63-1451-10*
 10 ft (3m) LENGTH

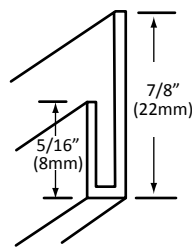

* AVAILABLE ON APPLICATION AND 12 PIECE MINIMUM FOR 8,9 & 10 ft LENGTHS

REF. D
STAINLESS STEEL DIVIDER BAR WITH GALVANIZED BACK PLATE
 FOR 1/16" (1.6mm) MATERIAL
BRIGHT FINISH
MODEL NO. J64-1450
 7 ft (2.1m) LENGTH
MODEL NO. J64-1450-8*
 8 ft (2.4m) LENGTH
MODEL NO. J64-1450-9*
 9 ft (2.7m) LENGTH
MODEL NO. J64-1450-10*
 10 ft (3m) LENGTH

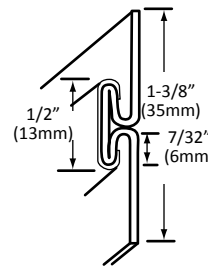

* AVAILABLE ON APPLICATION AND 12 PIECE MINIMUM FOR 8, 9 & 10 ft LENGTHS

REF. E
EXTENDED WIDE 304 STAINLESS STEEL CAP STRIP
 FOR 1/16" (1.6mm) MATERIAL
SATIN FINISH
MODEL NO. J63-2651-84
 7 ft (2.1m) LENGTH
MODEL NO. J63-2651-120
 10 ft (3m) LENGTH

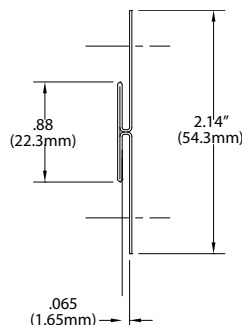
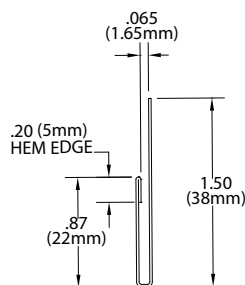

REF. F
EXTENDED WIDE 304 STAINLESS STEEL DIVIDER BAR WITH S/S BACK PLATE
 FOR 1/16" (1.6mm) MATERIAL
SATIN FINISH
MODEL NO. J64-2651-84
 7 ft (2.1m) LENGTH
MODEL NO. J64-2651-120
 10 ft (3m) LENGTH

Mouldings And Dividers

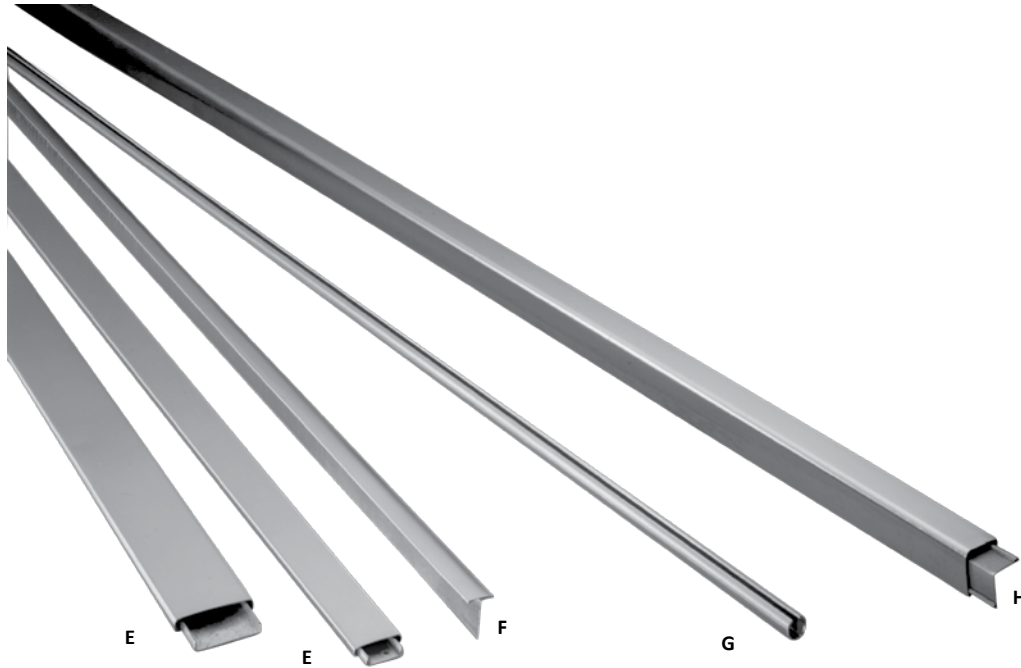

MOULDINGS AND DIVIDERS

REF. E

- GALVANIZED STEEL BACK PLATE
- STAINLESS STEEL SNAP-ON COVER
- BRIGHT FINISH

STAINLESS STEEL FLAT SNAP-ON MOULDING

MODEL NO.	WIDTH
J60-2240	3/4" (19mm)
J60-2260	1" (25mm)
J60-2270	1-1/4" (32mm)

12 ft (3.6m) LENGTHS

REF. F

STAINLESS STEEL LINE UP DIVIDER

MODEL NO. J65-4110

1/2" (13mm) FACE
12 ft (3.6m) LENGTH

STOCK LENGTH 12 ft (3.6m)

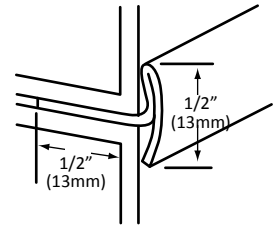

REF. G

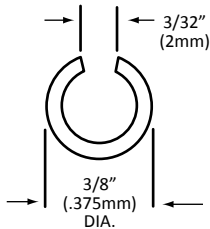

STAINLESS STEEL SPLIT TUBE MOULDING

20 ga (1mm) • 2B FINISH

MODEL NO. J62-0012

12 ft (3.6m) LENGTH, IDEAL FOR HEMMING/EDGING
MINIMUM ORDER 12 PIECES

REF. H

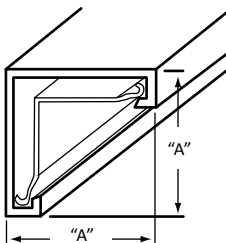

STAINLESS STEEL OUTSIDE CORNER SNAP-ON MOULDING

MODEL NO.	"A"
-----------	-----

J61-2470	3/4" x 3/4" (19mm x 19mm)
----------	---------------------------

12 ft (3.6m) LENGTHS

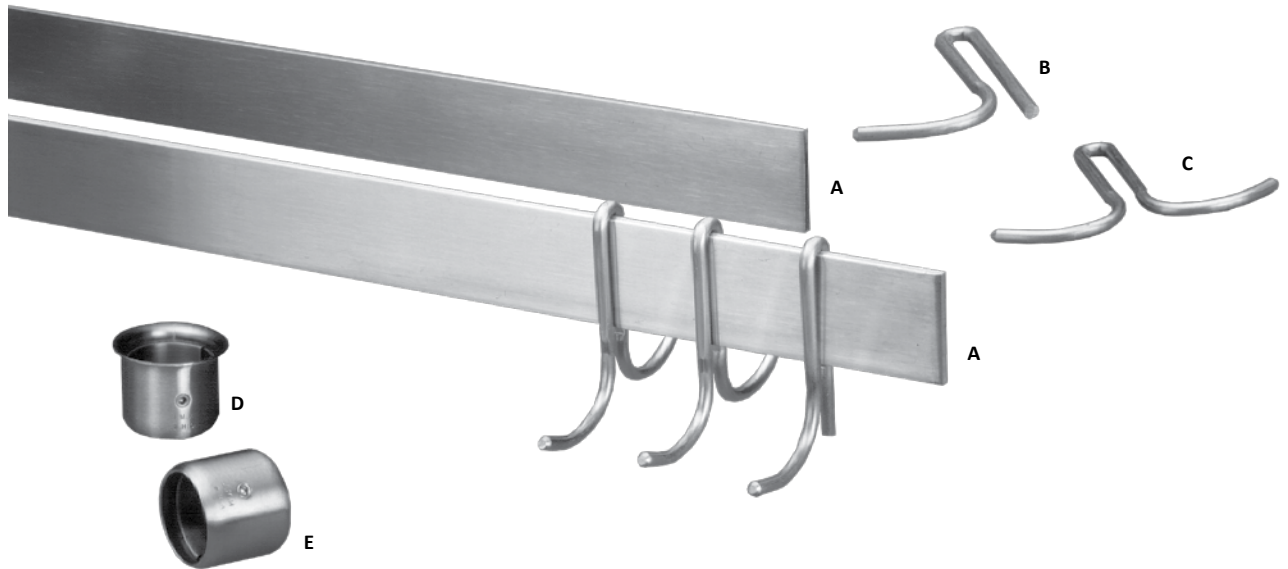

POT RACK COMPONENTS



REF. A

STAINLESS STEEL POT RACK BAND

- STAINLESS STEEL
- POLISHED (180 GRIT)
- PAPER INTERLEAVED
- AVAILABLE IN TWO STOCK SIZES

MODEL NO. J95-2250

1/4" (6mm) x 2" (51mm) x 10 FT. (3000mm)
200 ft /CTN., (60 meters),
TWENTY 10 ft (3000mm) LGTHS.

MODEL NO. J95-2187

3/16" (4.7mm) x 2" (51mm) x 10 FT. (3000mm)
200 ft /CTN., (60 meters),
TWENTY 10 ft (3000mm) LGTHS.



REF. B

STAINLESS STEEL SLIDING POT RACK HOOK SINGLE PRONG

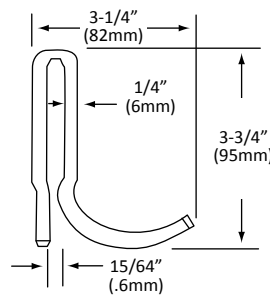

MODEL NO. J79-4115



REF. C

STAINLESS STEEL ZINC PLATED STEEL SLIDING POT RACK HOOKS DOUBLE PRONG

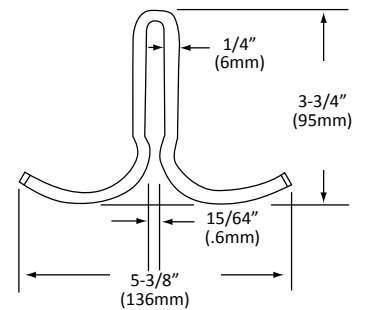

STAINLESS STEEL...MODEL NO. J77-4401
ZINC PLATED STEEL... MODEL NO. J77-4420



REF. D

STAINLESS STEEL SUPPORT COLLAR

FOR 1-5/8" (41mm) O.D. TUBING

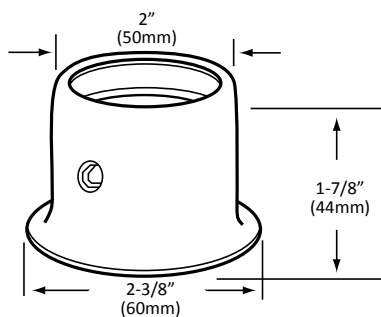

MODEL NO. A16-0206-C



REF. E

STAINLESS STEEL TUBULAR COLLAR

FOR 1-5/8" (41mm) O.D. TUBING

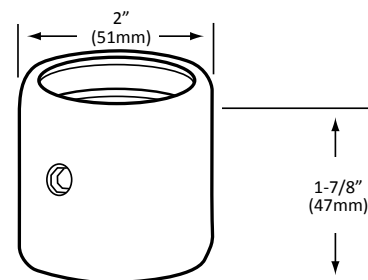

MODEL NO. A24-0206-C

Tubing Accessories

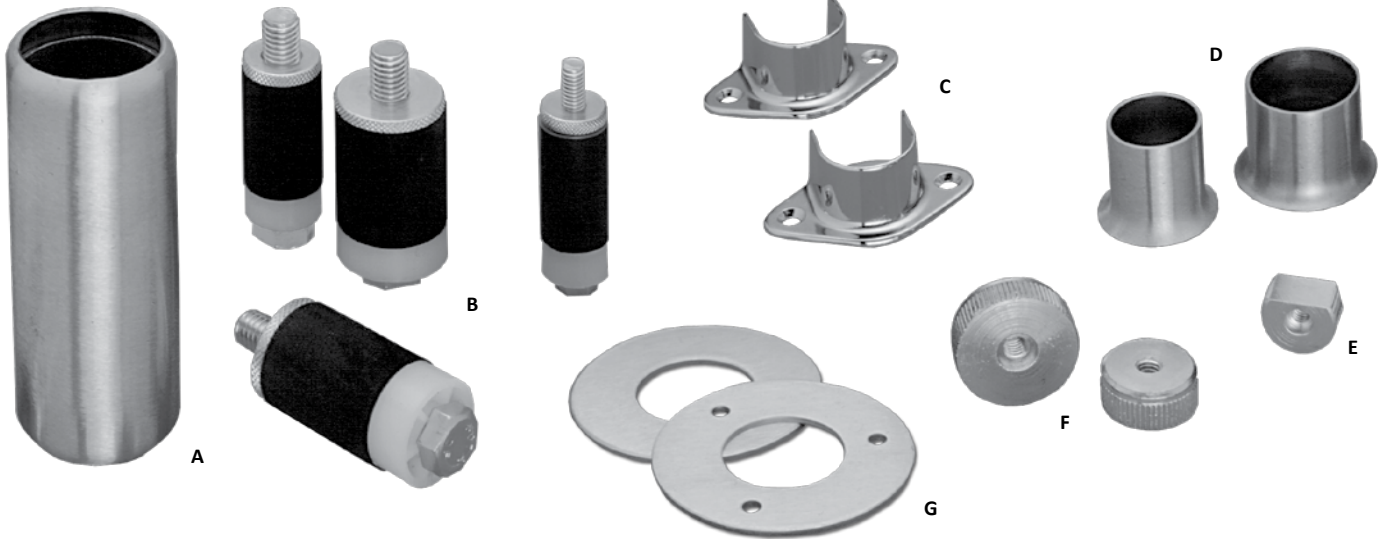

TUBING ACCESSORIES

REF. A

STAINLESS STEEL TUBULAR SHELF SUPPORT

FOR 1-5/8" (41mm) O.D. TUBING

- LONG LENGTH • ADJUSTABLE
- DOUBLE SET SCREW LOCKING
 - PLATED INSIDE LINER
- SUITABLE FOR A WIDE ARRAY OF CUSTOM APPLICATIONS

MODEL NO. A24-0207-C
5-1/4" (133mm) LG.

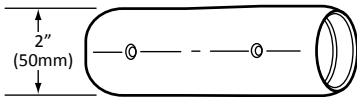

REF. B

EXPANDING FASTENERS

- FOR FAST KD INSTALLATION
- FOR ROUND OR SQUARE TUBING

MODEL NO.	TUBING SIZE
J57-7100	1" (25mm)
J57-7125	1-1/4" (32mm)
J57-7150	1-1/2" (38mm)
J57-7158	1-5/8" (41mm)

NOTE: J57-7100 USES 5/16" BOLT.
ALL OTHERS USE 1/2" BOLTS.

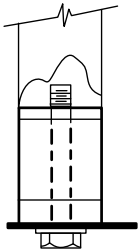

REF. C

CHROME PLATED OBLONG BASE END FLANGE

FOR 1" (25mm) O.D. TUBING

- DIE CAST METAL • CHROME PLATED

MODEL NO. J53-0125

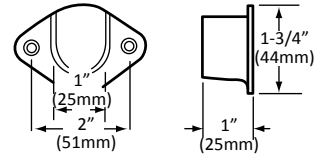

REF. D

STAINLESS STEEL ROUND BASE FLANGE

- STAINLESS STEEL

FOR 1" (25mm) O.D. TUBING... **MODEL NO. J52-0014**
FOR 1-1/4" (32mm) O.D. TUBING... **MODEL NO. J52-1250**

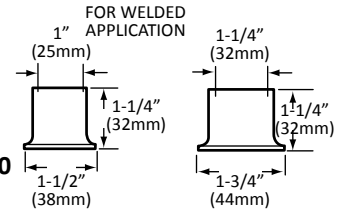

REF. E

PLATED STEEL KNURLED BUSHING

- PERMITS POSITIVE CONCEALED FASTENING

FOR 1" (25mm) O.D. TUBING

MODEL NO. J58-0100

16 GAUGE ONLY



FURNISHED WITH 1/4-20 TH'D

REF. F

PLATED STEEL KNURLED BUSHING

- PERMITS POSITIVE CONCEALED FASTENING

FOR 1-1/4" (32mm) O.D. TUBING... **MODEL NO. J58-0014***

FOR 1-5/8" (41mm) O.D. TUBING... **MODEL NO. J58-0158***

*16 GAUGE ONLY



FURNISHED WITH 5/16-18 TH'D

REF. G

STAINLESS STEEL ESCUTCHEON PLATE FLANGE

- 12 ga (2.6mm) STAINLESS STEEL W/ #4 SATIN FINISH
- FOR 1-5/8" (40mm) O.D. TUBING

WITH (3) 1/4" (6mm) DIA. HOLES **MODEL NO. J54-1583***

WITHOUT HOLES **MODEL NO. J54-1580**

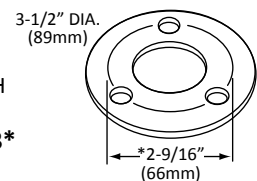



CUP DISPENSER AND ACCESSORIES



STAINLESS STEEL CUP DISPENSERS

- ALL STAINLESS STEEL CONSTRUCTION - SATIN FINISH, 24 GAUGE (.6mm)
- TOP LOADING WITH SPRING TENSION
- LOW PROFILE ... ONLY 9/32" (7mm) PROTRUSION ABOVE COUNTERTOP
- REMOVABLE ... 1/4 TURN RELEASES DISPENSER FROM COUNTERTOP
- GASKETED COUNTER SEAL
- WAX AND FOAM CUP MODEL

STAINLESS STEEL COUNTER MOUNT CUP DISPENSERS

MODEL NO.	TYPE	CUP SIZE	CUP RIM DIA. (ADJ.)	COUNTER HOLE DIA. REQ'D	OUTER FLANGE DIA.	O.A. LENGTH
C3200CV	VERTICAL MOUNT	6 to 12 oz (180 to 360ml)	2-7/32" to 3-3/16" (56 to 81mm)	4-3/16" (110mm)	5-3/8" (135mm)	24" (610mm)
C3200CH	HORIZONTAL MOUNT	6 to 12 oz (180 to 360ml)	2-7/32" to 3-3/16" (56 to 81mm)	4-3/16" (110mm)	5-3/8" (135mm)	24" (610mm)
C3200CF	FOAM CUP	6 to 12 oz (180 to 360ml)	2-7/32" to 3-3/16" (56 to 81mm)	4-3/16" (110mm)	5-3/8" (135mm)	24" (610mm)
C3400CV	VERTICAL MOUNT	12 to 24 oz (360 to 720ml)	2-1/2" to 3-7/8" (63 to 98mm)	4-11/16" (120mm)	5-7/8" (150mm)	24" (610mm)
C3400CH	HORIZONTAL MOUNT	12 to 24 oz (360 to 720ml)	2-1/2" to 3-7/8" (63 to 98mm)	4-11/16" (120mm)	5-7/8" (150mm)	24" (610mm)
C3400CF	FOAM CUP	12 to 24 oz (360 to 720ml)	2-1/2" to 3-7/8" (63 to 98mm)	4-11/16" (120mm)	5-7/8" (150mm)	24" (610mm)
C3500CV	VERTICAL MOUNT	32 to 46 oz (960 to 1380ml)	4" to 4-7/8" (102 to 124mm)	5-11/16" (145mm)	6-3/4" (170mm)	24" (610mm)
C3500CH	HORIZONTAL MOUNT	32 to 46 oz (960 to 1380ml)	4" to 4-7/8" (102 to 124mm)	5-11/16" (145mm)	6-3/4" (170mm)	24" (610mm)
C3500CF	FOAM CUP	32 to 46 oz (960 to 1380ml)	4" to 4-7/8" (102 to 124mm)	5-11/16" (145mm)	6-3/4" (170mm)	24" (610mm)

NOTE: VERTICAL MOUNT CUP DISPENSERS OPERABLE TO 45°

ACCESSORIES AVAILABLE FROM STOCK:

- LID DISPENSERS: STAND OR WALL MOUNT FOR EASY LOADING
- WALL MOUNT OR STAND MOUNT CUP DISPENSERS...TOP LOADING, GRAVITY FEED
- CUP DISPENSER STANDS



PATENTED ADJUSTABLE THROAT LETS YOU ADAPT THE UNIVERSAL COLLAR TO ANY DISPENSING NEED

All it takes is a simple screwdriver adjustment, which keeps it locked in for any one type of cup until you want to change to another size.

Drip Plate

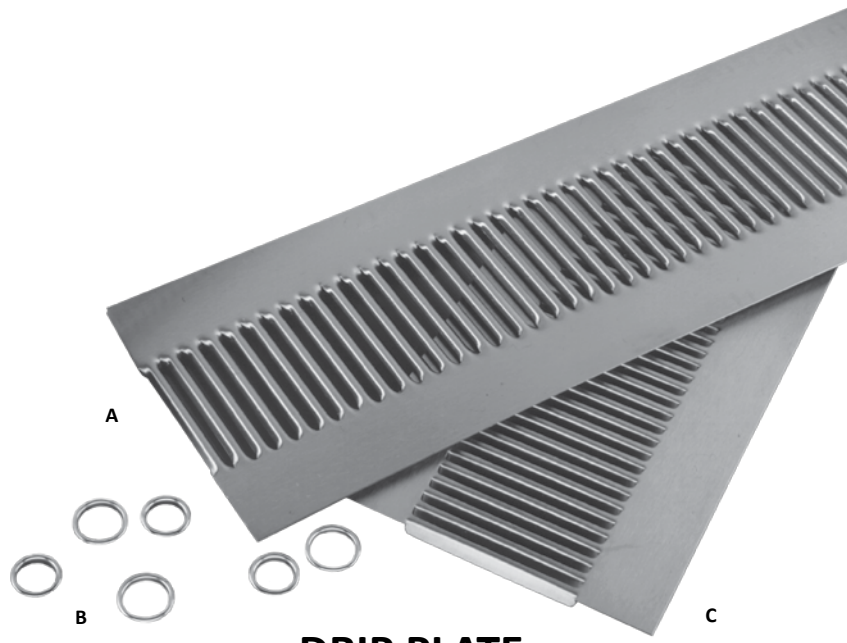

DRIP PLATE

REF. A

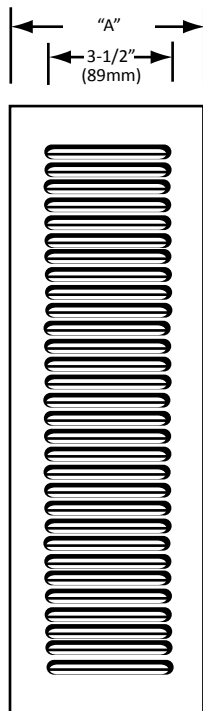

**STAINLESS STEEL
DRIP PLATE
ECONOMY TYPE**

- ECONOMY DESIGN
- 24 ga (.6mm) WITH #4 FINISH

**ECONOMY TYPE
STAINLESS STEEL DRIP PLATE**

MODEL NO.	"A"	LENGTH
J81-5206-6-C	6" (152mm)	72" (1829mm)
J81-5207-6-C	7" (178mm)	72" (1829mm)
J81-5209-6-C	9" (229mm)	72" (1829mm)

PACKAGED 5 PCS. PER BOX

REF. B

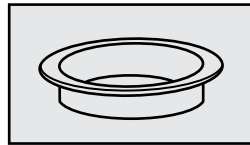

**BRASS NICKEL PLATED
FINISHING RINGS**

**MODEL NO.
J86-4300**

FOR 7/8" (22mm) DIA. HOLE

**MODEL NO.
J86-4301**

FOR 1" (25mm) DIA. HOLE

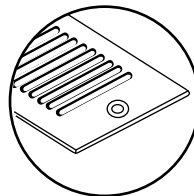

REF. C

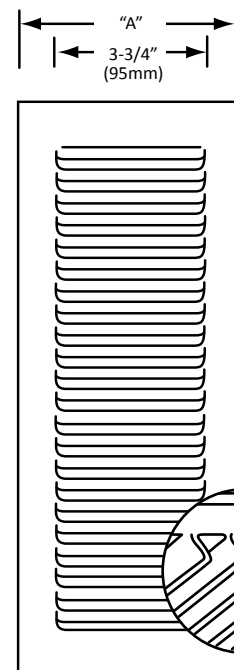

**STAINLESS STEEL
DRIP PLATE
NON-SPLASH**

- HEAVY DUTY DESIGN
- 21 ga (.8mm) WITH #4 FINISH

**NON-SPLASH
STAINLESS STEEL DRIP PLATE**

MODEL NO.	"A"	LENGTH
J80-5107-6-C	7" (178mm)	72" (1829mm)
J80-5109-6-C	9" (229mm)	72" (1829mm)

PACKAGED 5 PCS. PER BOX

End Caps And Lid Cover Brackets

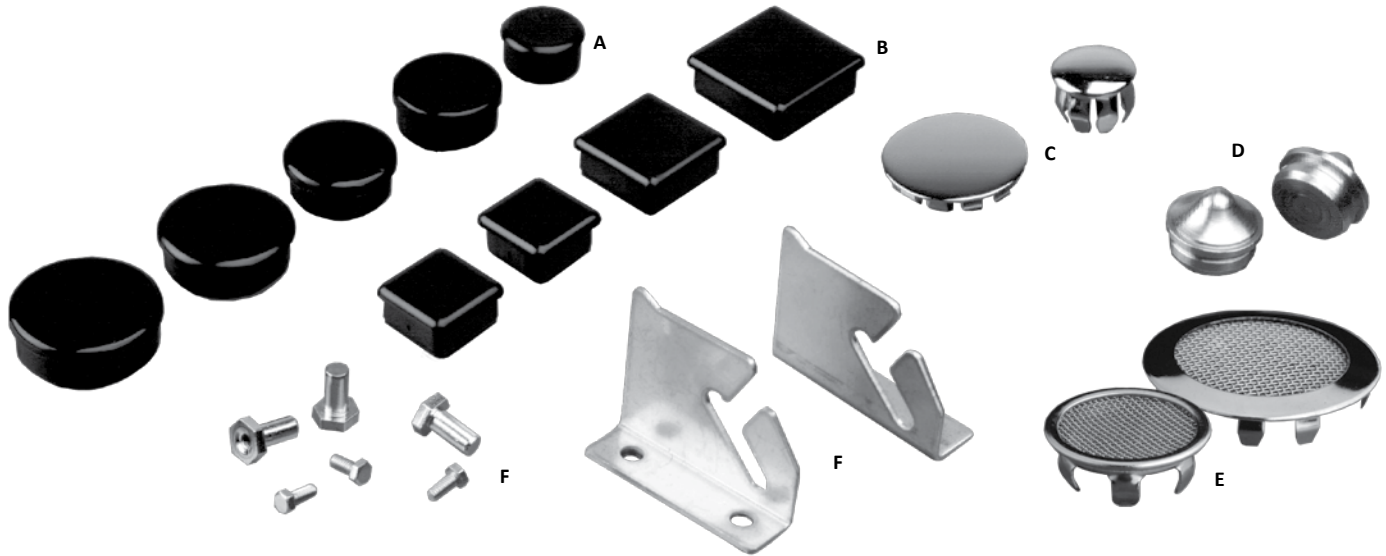

END CAPS AND LID COVER BRACKETS

REF. A

**THERMOPLASTIC
END CAPS
FOR ROUND TUBING**
MATERIAL: BLACK NYLON

MODEL NO.	O.D.	GAUGE
J16-1000-RD	1" (25mm)	18 (1.2mm)
J16-1250-RD	1-1/4" (32mm)	18 (1.2mm)
J16-2125-RD	1-1/4" (32mm)	16 (1.5mm)
J16-1500-RD	1-1/2" (38mm)	16 (1.5mm)
J16-1625-RD	1-5/8" (41mm)	16 (1.5mm)

REF. B

**THERMOPLASTIC
END CAPS
FOR SQUARE TUBING**
MATERIAL: BLACK NYLON

MODEL NO.	O.D.	GAUGE
J16-1000-SQ	1" x 1" (25 x 25mm)	18 (1.2mm)
J16-1001-SQ	1" x 1" (25 x 25mm)	16 (1.5mm)
J16-1250-SQ	1-1/4" x 1-1/4" (32 x 32mm)	18 (1.2mm)
J16-1500-SQ	1-1/2" x 1-1/2" (38 x 38mm)	16 (1.5mm)

NOTE: * INDICATES OUTSIDE DIMENSIONS

REF. C **NICKEL PLATED
END CAPS
FOR ROUND TUBING**

MODEL NO. J16-0201 FOR 1" (25mm) O.D. TUBING	MODEL NO. J16-0158 FOR 1-5/8" (41mm) O.D. TUBING
---	---

REF. D **SOLID STAINLESS
END CAPS
MODEL NO.
J16-0100**

18 ga (1mm)
FOR 1" (25mm) O.D. TUBING
(WELD APPLICATION)

REF. E **NICKEL PLATED AND SOLID
STAINLESS SCREENED
HOLE PLUGS**

MODEL NO. J16-0201-SP
FOR 1" (25mm) DIA. HOLE

MODEL NO. J16-0201-SPSS
FOR 1" (25mm) DIA. HOLE

MODEL NO. J16-0158-SPSS
FOR 1-5/8" (41mm) DIA. HOLE

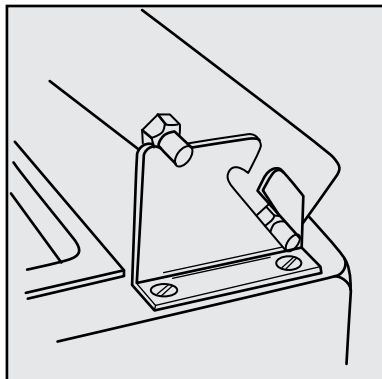

REF. F **STAINLESS STEEL
LID COVER
BRACKET ASSEMBLY**

- EASY INSTALLATION
- LIFT-OFF DESIGN

CAN BE FASTENED TO STAINLESS STEEL LIDS OR PLASTIC BUBBLE COVERS. DESIGNED FOR EASY LIFT-OFF AND FOR HOLD-OPEN POSITION FOR EASE OF SERVING.

MODEL NO. J33-1532

ASSEMBLY CONSISTS OF RIGHT & LEFT HAND BRACKETS COMPLETE WITH 4 PIVOT PINS WITH SCREW.

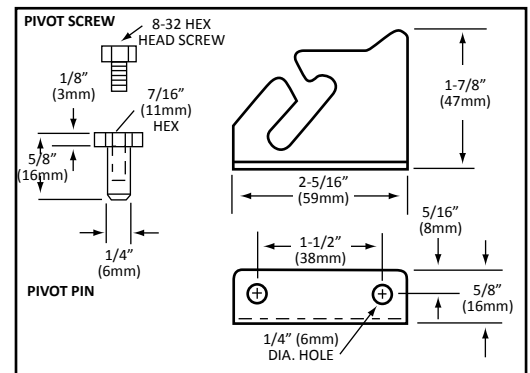

FOR STAINLESS STEEL PIVOT PINS ORDER **MODEL NO. J32-X001**
FOR STAINLESS STEEL PIVOT SCREWS ORDER **MODEL NO. J32-X002**

Sink / Table / Bar Accessories

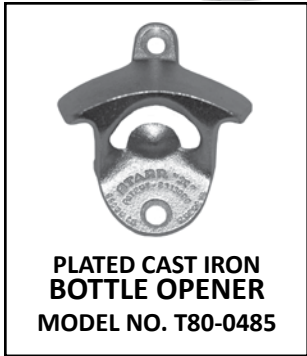

SINK / TABLE / BAR ACCESSORIES

REF. A

SOLID RUBBER SCRAP BLOCK
FITS STANDARD 5-3/4" (146mm) DIA. OPENING
MODEL NO. J92-9360

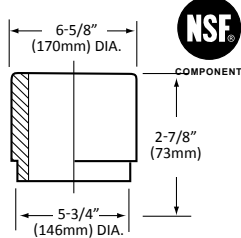

REF. B

SOLID RUBBER SCRAP BLOCK FUNNEL SHAPED
FITS STANDARD 5-3/4" (146mm) DIA. OPENING
MODEL NO. J92-5000

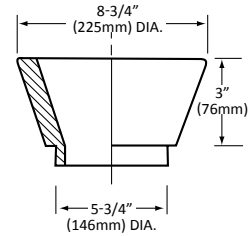

REF. C

STAINLESS STEEL SCRAP CHUTE
FITS STANDARD 6" (152mm) DIA. OPENING
MODEL NO. J92-1000

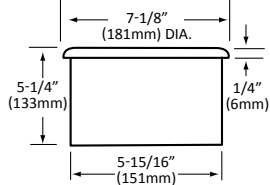

REF. D

STAINLESS STEEL DIPPERWELL ASSEMBLY

- FITS INTO 6" (152mm) DIA. OPENING
- TYPE 18-8 STAINLESS STEEL INNER AND OUTER SHELL
- 9-1/2" (241mm) OVERALL LENGTH
- COMPLETE WITH STAINLESS STEEL DRAIN AND 1-1/2" (38mm) O.D. X 4" (102mm) LONG BRASS NICKEL PLATED TAILPIECE

MODEL NO. K30-1000 WITHOUT FAUCET
MODEL NO. K30-1010 WITH FAUCET
MODEL NO. K22-3100 FAUCET ONLY

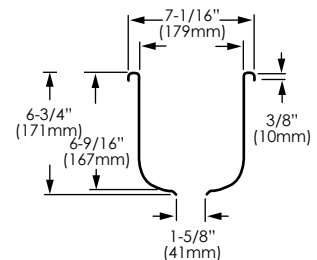

ALSO AVAILABLE AS INDIVIDUAL COMPONENTS
1/2" NPS MALE INLET FURNISHED WITH 1/4" NPT MALE UNION TAILPIECE AND MOUNTING HARDWARE

REF. E AND F

64 oz ICE SCOOP WITH HAND GUARD AND SANIGUARD® ANTIMICROBIAL PRODUCT PROTECTION

MODEL NO. SIS-6400

WIRE FRAME WALL MOUNT BRACKET
MODEL NO. SIS-1000

- MOLDED HAND GUARD HELPS PREVENT ACCIDENTAL CONTACT OF HAND AND ICE, REDUCING THE POTENTIAL TRANSFER OF GERMS TO THE ICE
- IDEAL FOR USE IN OEM ICE BINS OR AS A REPLACEMENT ICE SCOOP
 - MAY ALSO BE USED AS A DRY MEASURE SCOOP
 - HOLE IN HAND GUARD TO PERMIT USE OF A CHAIN
 - 64 oz CAPACITY • PATENT PENDING
 - WIRE FRAME WALL MOUNT BRACKET AVAILABLE
- SANIGUARD® ANTIMICROBIAL PRODUCT PROTECTION HELPS TO RETARD THE GROWTH OF BACTERIA, MOLD AND MILDEW THAT CAN CAUSE ODORS, STAINING AND PRODUCT DETERIORATION

NOTE: THE SANIGUARD® ANTIMICROBIAL TREATMENT IS DESIGNED TO PROTECT THE PRODUCT ITSELF AND WILL NOT PROTECT USERS OR OTHERS FROM FOOD-BORNE OR DISEASE CAUSING MICROORGANISMS. CONTINUE TO FOLLOW GOOD HAND HYGIENE AND CLEANING PRACTICES.

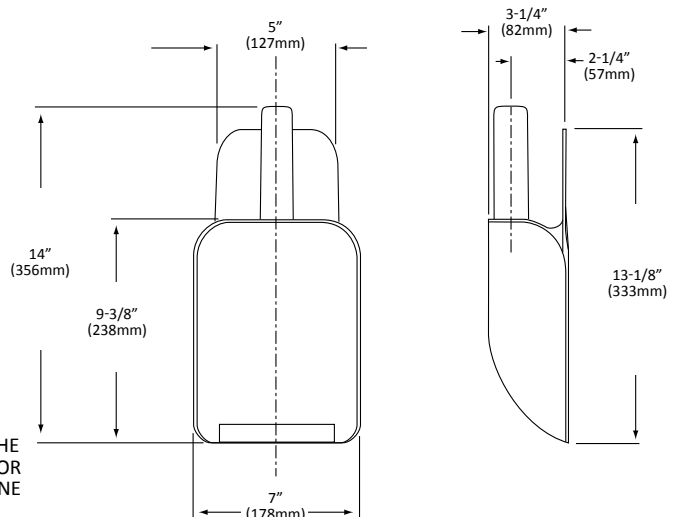

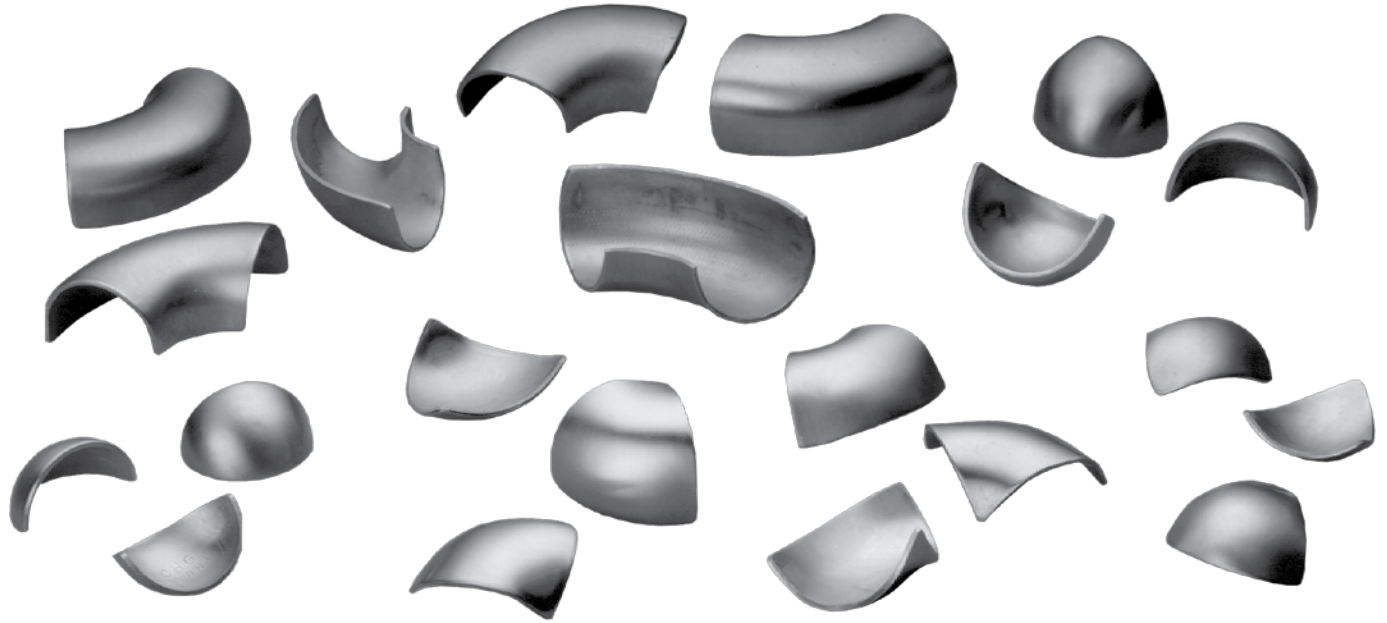

COUNTER AND SINK INSERTS

STAINLESS STEEL COVE CORNER INSERT

14 ga (1.8mm)

MODEL NO. J70-4701

FOR NOMINAL 1-1/2" (38mm) ROLLS WITH 1" (25mm) INSIDE RADIUS

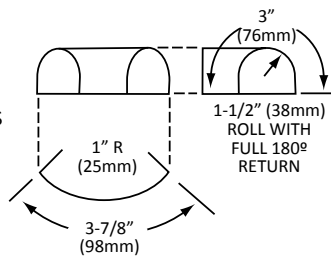
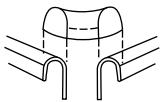

STAINLESS STEEL COVE CORNER INSERT

14 ga (1.8mm)

MODEL NO. J70-4691

FOR NOMINAL 1-1/2" (38mm) ROLLS WITH 1" (25mm) INSIDE RADIUS

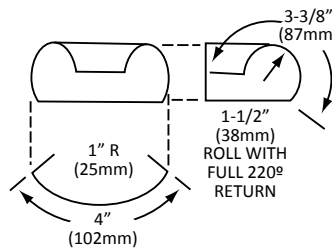
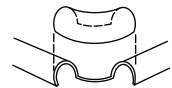

STAINLESS STEEL BULL NOSE INSERT

14 ga (1.8mm)

MODEL NO. J72-4711

1.5" (38mm) ROLL, 3/4" SPHERICAL RADIUS, .073 GAUGE

MODEL NO. J72-4731

2" (51mm) ROLL, 1" SPHERICAL RADIUS, .073 GAUGE

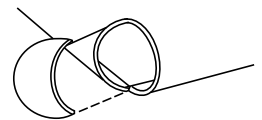
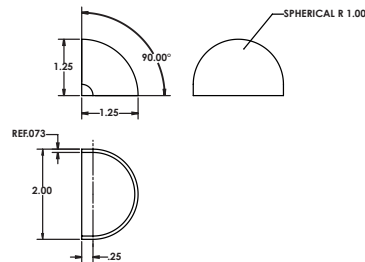
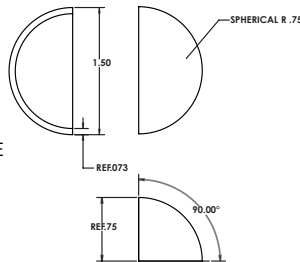

QUARTER SPHERES FOR NOMINAL 1-1/2" (38mm) AND 2" (51mm)

STAINLESS STEEL TRIANGULAR INSERT

14 ga (1.8mm)

MODEL NO. J70-4801

FULL SPHERICAL R 1.00

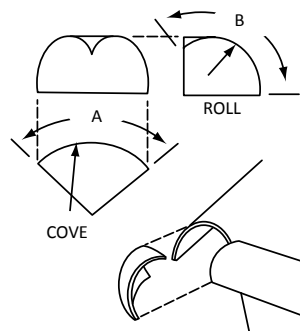
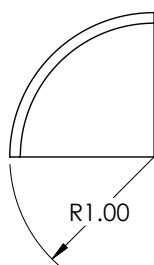
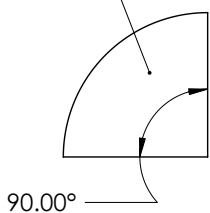

STAINLESS STEEL SQUARE CORNER INSERT

14 ga (1.8mm)

MODEL NO. J74-4721

1-1/2" (38mm) COVE,
A=2-1/4" (57mm),
B=2-5/16" (59mm)

MODEL NO. J74-4723

1-3/4" (44mm) COVE,
A=2-7/8" (73mm),
B=2-11/16" (66mm)

MODEL NO. J74-4725

1-5/8" (41mm) COVE,
A=2-9/16" (65mm),
B=2-1/2" (63mm)

Brite Gard™ Cleaning Products



Biodegradable
100% Recyclable

MODEL NO.
Q85-2128

MODEL NO.
Q85-2004

MODEL NO.
Q85-2016

Brite Gard™ STAINLESS STEEL CLEANER/PROTECTANT

- CLEANS, SHINES & PROTECTS
- DOES NOT LEAVE OILY RESIDUE
- ENVIRONMENTALLY FRIENDLY – USES MANUAL PUMP SPRAYER, NOT AEROSOLS
- VIRTUALLY ELIMINATES FINGERPRINTS & SMUDGES
 - SPECIFICALLY FORMULATED FOR USE ON INDOOR/OUTDOOR STAINLESS STEEL APPLIANCES
 - SAFE – USES FOOD GRADE INGREDIENTS

MODEL NO.	DESCRIPTION	WT. PER BOTTLE	BOX/CASE QTY
Q85-2004 (shown)	Pump Spray	4 fl. oz. (118ml)	Each
Q85-200424	Pump Spray	4 fl. oz. (118ml)	24/Box
Q85-2016 (shown)	Pump Spray	16 fl. oz. (474ml)	Each
Q85-201606	Pump Spray	16 fl. oz. (474ml)	6/Box
Q85-201612	Pump Spray	16 fl. oz. (474ml)	12/Case
MODEL NO.	DESCRIPTION	WT. PER REFILL	BOX QTY
Q85-2128 (shown)	Refill	1 gal. (3.8ml)	Each
Q85-212804	Refill	1 gal. (3.8ml)	4/Box



MODEL NO.
Q85-8000
Q85-8500

MODEL NO.
Q85-7000
Q85-7500

Brite Gard® ALL PURPOSE WIPERS

- MADE WITH 25% RECYCLED CELLULOSE FIBERS
- PERFECT FOR HEAVY DUTY WET/DRY WIPING APPLICATIONS
- IDEAL FOR MOST METAL WORKING AND MESSY FLUID APPLICATIONS
- INTERFOLDS ARE PERFECT FOR JOBS THAT REQUIRE LARGE WIPERS
 - TWO TIMES STRONGER THAN THE COMPETITION
- COST EFFECTIVE ALTERNATIVE TO CLOTH TOWELS & RAGS
 - LOW LINT



HEAVY-WEIGHT QUARTERFOLD (60 count) MODEL NO. Q85-7000		LIGHT-WEIGHT QUARTERFOLD (90 count) MODEL NO. Q85-7500		SUPER STRENGTH INTERFOLD (126 count) MODEL NO. Q85-8000		LIGHT-WEIGHT INTERFOLD (135 COUNT) MODEL NO. Q85-8500	
Sheet Size:	12-1/2" x 13" (138mm x 330mm)	Sheet Size:	12-1/2" x 13" (138mm x 330mm)	Sheet Size:	9-1/2" x 16-1/2" (241mm x 419mm)	Sheet Size:	9-1/2" x 16-1/2" (241mm x 419mm)
Sheet Per Case:	720	Sheet Per Case:	1080	Sheet Per Case:	1008	Sheet Per Case:	1080
Case Quantity:	12	Case Quantity:	12	Case Quantity:	8	Case Quantity:	8
Case Weight:	15lbs (7kg)	Case Weight:	15lbs (7kg)	Case Weight:	18lbs (8kg)	Case Weight:	20lbs (9kg)

Roller Assemblies, Conveyor Roller Components and Wheels

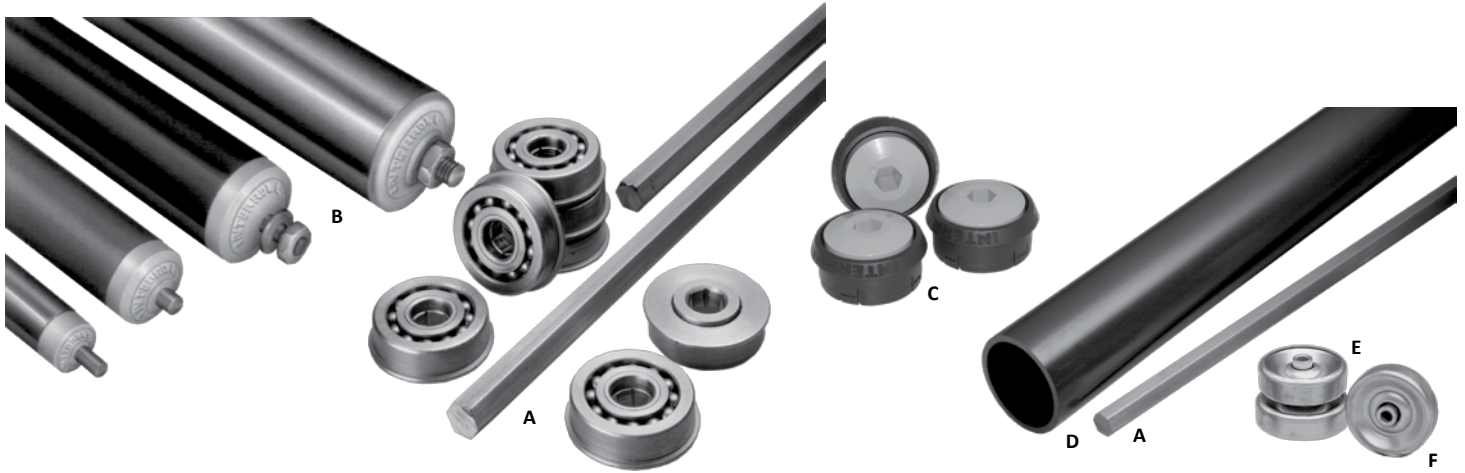

ROLLER ASSEMBLIES AND COMPONENTS

REF. A STAINLESS STEEL CONVEYOR COMPONENTS

STAINLESS STEEL CONVEYOR BEARING

FLANGED BALL BEARING WHEEL ASSEMBLY FOR 1-5/8" (41mm) O.D. 16 ga (1.5mm) TUBING

MODEL NO. B29-0080

STAINLESS STEEL HEX AXLE ROD

7/16" (11mm) SOLID HEX AXLE ROD AVAILABLE IN 6 ft (1.9m) LENGTHS

MODEL NO. B80-0716

REF. B MADE TO ORDER COMPLETE ROLLER ASSEMBLIES

COMPLETE ROLLER ASSEMBLIES (TUBING AND SERIES 1100 PLASTIC ROLLER BEARINGS) ARE AVAILABLE FABRICATED TO INDIVIDUAL REQUIREMENTS.

THESE COMPLETE ASSEMBLIES PERMIT INDIVIDUAL SPECIFICATIONS OF TUBING DIAMETER AND MATERIAL, SHAFT MATERIAL, SHAFT SIZE AND A VARIETY OF MOUNTINGS. THE VARIABLES INCLUDE.

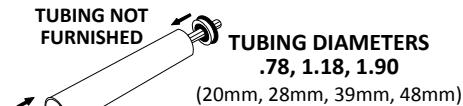

TUBING MATERIALS
PLASTIC (PVC), ALUMINUM AND STAINLESS STEEL

SHAFT MATERIALS
CARBON STEEL, ALUMINUM AND STAINLESS STEEL

SHAFT SIZES
FROM .192", .250" OR .312" DIA. AND 5/16" OR 7/16" HEX
(5mm, 6mm, 8mm) (8mm or 11mm)

MOUNTINGS
PLAIN, THREADED, TAPPED AND SPRING LOADED

NOTE: WE WELCOME YOUR INQUIRIES FOR SPECIFIC DESIGNS TO SATISFY YOUR INDIVIDUAL REQUIREMENTS. HOWEVER, NOT ALL COMBINATIONS ARE POSSIBLE. PLEASE CONTACT OUR SALES OFFICE FOR ASSISTANCE IN DESIGNING YOUR CUSTOM ROLLER ASSEMBLIES. ALLOW 4-6 WEEKS FOR DELIVERY OF COMPLETE ROLLER ASSEMBLIES.

CONVEYOR ROLLER COMPONENTS AND WHEELS

REF. C PLASTIC CONVEYOR ROLLER BEARINGS

- STOCKED FOR 1.90" (48mm) O.D. TUBING
- MOLDED POLYPROPYLENE • DOUBLE LABYRINTH SEALS
- STAINLESS STEEL (18-8) BALLS • APPROVED FOR FOODSERVICE USE
- MAY BE STEAM CLEANED • OPERATES AT TEMPERATURES UP TO 150°F (66° C)

MODEL NO.	SHAFT SIZE
IR-0312RD	5/16" (8mm) DIA.
IR-0312HX	5/16" (8mm) HEX
IR-0375HX	7/16" (11mm) HEX

REF. D PVC ROUND TUBING (GRAY) FOR CONVEYOR ROLLERS

- 1.90" (48mm) O.D. FOR 1100 SERIES ROLLERS

MODEL NO. IR-1190
4 ft (1220mm) LENGTH

REF. E STAINLESS STEEL WHEEL

MODEL NO. IR-1061

ZINC PLATED STEEL with OFFSET BUSHING

MODEL NO. IR-2112

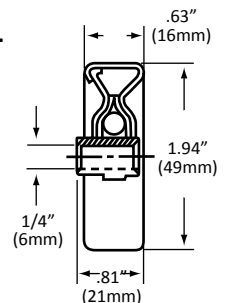
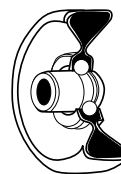

REF. F STAINLESS STEEL and STEEL WHEELS

- IDEAL FOR DRAWER SLIDES AND CONVEYOR ASSEMBLIES • HEAT TREATED INNER AND OUTER RACEWAYS • ALL METAL CONSTRUCTION

STAINLESS STEEL WHEEL
MODEL NO. IR-0031
STEEL WHEEL ZINC PLATED
MODEL NO. IR-2263

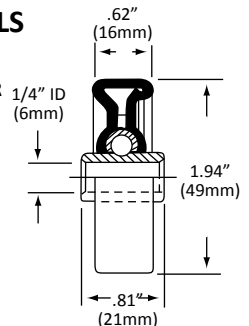
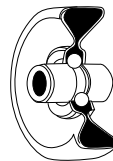

Custom Conveyor Roller Order Form

CUSTOM CONVEYOR ROLLER ORDER FORM

INDICATE ROLLER SPECIFICATIONS BELOW.
NOTE: REFER TO THE MATRIX FOR AVAILABLE TUBING/SHAFT COMBINATIONS.

STANDARD LEAD TIME - 4 WEEKS ARO
 CUSTOM ROLLERS ARE NOT RETURNABLE.

QUANTITY: _____

TUBE DIAMETER (in):

- 0.62 _____
- .075 _____
- 0.78 _____
- 1.12 _____
- 1.18 _____
- 1.90 _____

TUBE MATERIAL:

- STAINLESS STEEL _____
- GRAY PVC _____
- ANODIZED ALUMINUM _____
- MILL FINISH ALUMINUM _____
- GALVANIZED STEEL _____

SHAFT TYPE:

- SPRING LOADED _____
- THREADED _____
- END DRILLED AND TAPPED _____

SHAFT THREAD SIZE:

- 10-32 _____
- 1/4-20 _____
- 5/16-18 _____

SHAFT MATERIAL:

- CARBON STEEL _____
- STAINLESS STEEL _____

SHAFT SIZE:

- .192 DIA. _____
- .250 DIA. _____
- .312 DIA. _____
- .312 HEX _____
- .437 HEX _____

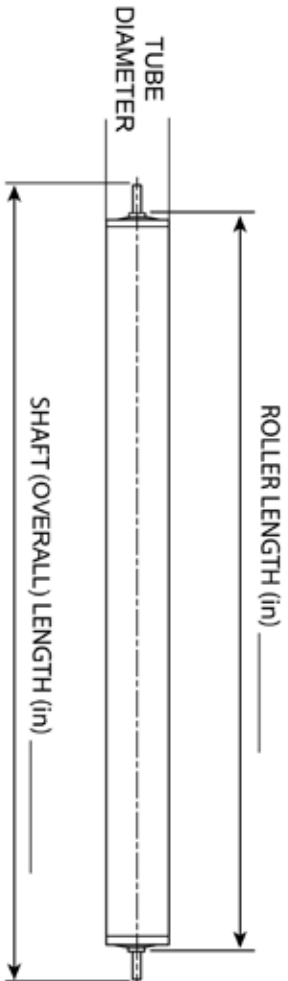

Tube Diameter	Tube Material	Wall Thickness	0.192" round C/S or S/S spring loaded	0.192" round C/S or S/S threaded 10-32	1/4" round C/S or S/S or aluminum spring loaded	1/4" round C/S or S/S threaded 1/4 - 20	5/16" round C/S or S/S spring loaded	5/16" round C/S or S/S threaded 5/16 - 18	5/16" hex C/S or S/S spring loaded	3/8" hex C/S spring loaded	7/16" hex C/S or S/S spring loaded	7/16" hex C/S or S/S end drilled and tapped 1/4 - 20 x 5/8 deep
0.62"	Polished S/S	.035"	•									
	Polished S/C	.035"										
0.75"	Anodized Aluminum	.035"			•	•	•	•	•	•	•	•
	Gray PVC	.060"										
1.12"	Anodized Aluminum	.050"			•	•	•	•	•	•	•	•
	Gray PVC	.070"										
1.18"	Mill Finish Aluminum	.065"			•	•	•	•	•	•	•	•
	Galvanized Carbon Steel	.065"										
1.9"	Polished S/S	.065"										
	Gray PVC	.11"										

COMPANY NAME: _____

CONTACT: _____

PHONE: _____

EMAIL: _____

STREET: _____

CITY/STATE/ZIP: _____

P.O. #: _____



1890 Swarthmore Avenue • PO Box 2020 • Lakewood, NJ 08701
 Tel 800-526-3694 • 732-363-4700 • Fax 732-364-8110
 www.componenthardware.com

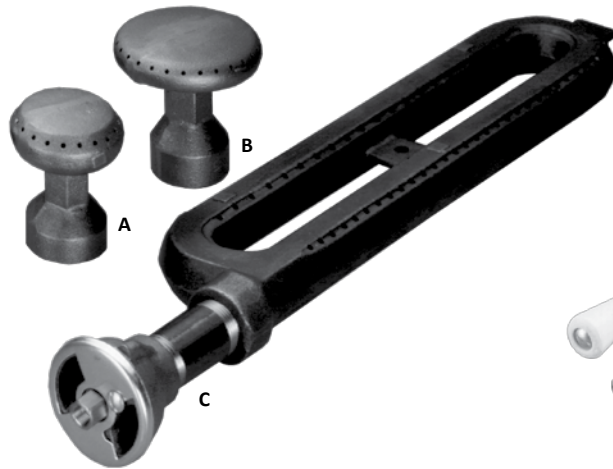

GAS BURNERS

MUSHROOM BURNERS

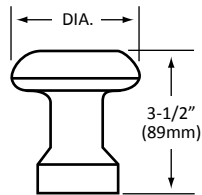

REF.	MODEL NO.	DIA.	BTU/HR	REC. FOR
A	G22-4310	3" (76mm)	5,000	1-3 gal (3.8-11 lit)
B	G22-4320	4" (102mm)	7,000	3-4 gal (11-15 lit)

NOTE: ORDER AIR MIXING PLATE SEPARATELY AS G44-4360

REF. C

LOOP BURNER

• END INLET • 30,000 BTU/HR

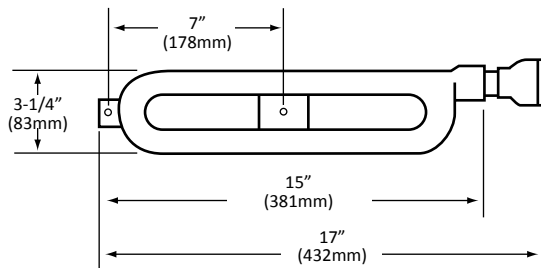

MODEL NO. G27-1250
FURNISHED COMPLETE WITH AIR MIXING CHAMBER
AND ORIFICE FOR NATURAL AND LP GAS



RING BURNER ASSEMBLIES

REF. C

RING BURNER WITH INSULATED HANDLE BURNER VALVE

MODEL NO. G12-6550
RATING: 22,000 BTU/HR

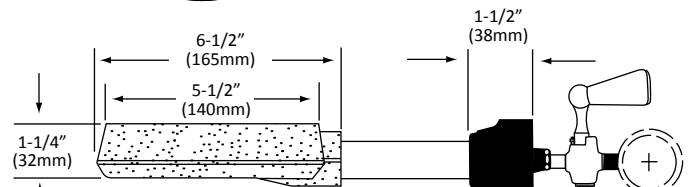
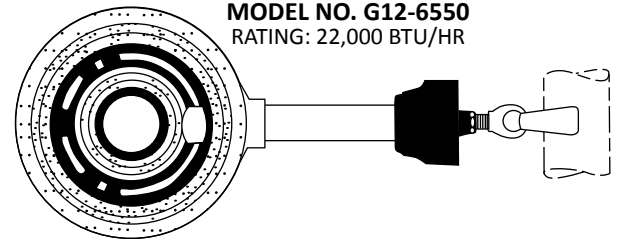

NOTE: MANIFOLD AND NIPPLE (3/4" N.P.T.) NOT SUPPLIED
6" RING BURNER ONLY **MODEL NO. G12-X001**

REF. D

RING BURNER WITH ADJUSTABLE SLIP FIT ORIFICE BURNER VALVE

MODEL NO. G10-6550
RATING: 22,000 BTU/HR

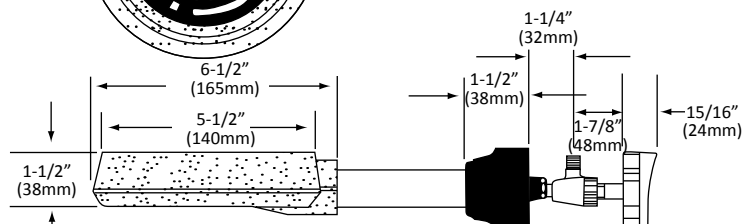
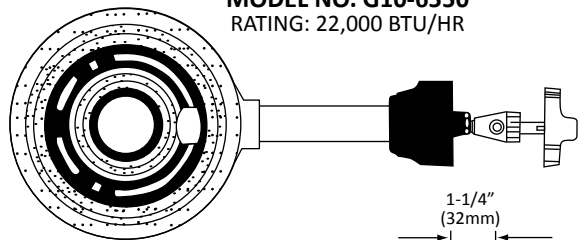

NOTE: MANIFOLD AND NIPPLE (3/4" N.P.T.) NOT SUPPLIED

Gas Burner Components

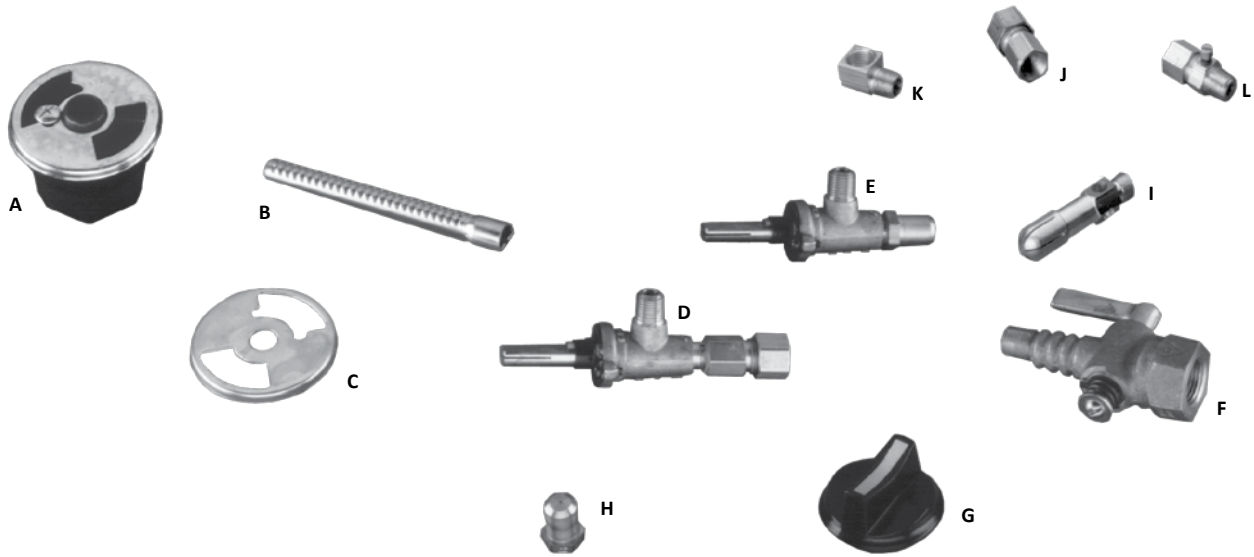

GAS BURNER COMPONENTS

REF. A

AIR MIXING CHAMBER

FREE FLOW CHAMBER WITH AIR MIXING PLATE
MODEL NO. G46-4360 FOR 1/8" N.P.T. ORIFICE
MODEL NO. G46-4361 FOR SLIP FIT ORIFICE

REF. B

BURNER VALVE EXTENSION

- FITS STANDARD SLOTTED "D" BURNER VALVES
- 3" (76mm) MAXIMUM ADJUSTMENT

MODEL NO. G48-0005

REF. C

AIR MIXING PLATE

ZINC PLATED
MODEL NO. G44-4360
 SPECIAL SIZES MAY BE SUPPLIED IN QUANTITY

REF. D

BURNER VALVES

- 1/8" N.P.T. MALE INLET

MODEL NO. G40-6451
 COMPRESSION FIT FOR 5/16" (8mm) O.D. TUBING

REF. F

BURNER VALVE WITH BRASS HANDLE

- 1/8" N.P.T. MALE INLET x 3/8" N.P.T. FEMALE

MODEL NO. G38-5330

REF. E

MODEL NO. G40-6452
 ADJUSTABLE SLIP FIT ORIFICE

REF. G

VALVE HANDLE

- BLACK THERMOPLASTIC
- FOR ALL STANDARD VALVES WITHOUT INDICATOR

MODEL NO. G50-5420

REF. H

THREADED ORIFICE MODEL NO. G36-4370

THIS PART IS SUPPLIED WITH AN .021 (.5mm) DIAMETER GUIDE. HOLE, DIFFERENT GASSES, FEEDING PRESSURES AND ATMOSPHERIC PRESSURES, REQUIRE DIFFERENT ORIFICE DIAMETERS. CONSULT YOUR UTILITY SUPPLIER FOR CORRECT DIAMETER.

REF. I

JET BURNER, BRASS
MODEL NO. G28-6491

REF. J

COUPLING, BRASS
 1/8" N.P.T. FEMALE INLET FOR 5/16" (8mm) O.D. TUBING
MODEL NO. G32-6470

REF. K

ELBOW, BRASS
 1/8" N.P.T. FOR USE WITH G28-6491
MODEL NO. G30-6480

REF. L

PILOT VALVE, BRASS
 ADJUSTABLE
 1/8" N.P.T. MALE INLET FOR 1/4" (6mm) O.D. TUBING
MODEL NO. G34-6460

Index

MODEL NO.	PAGE NO.	MODEL NO.	PAGE NO.	MODEL NO.	PAGE NO.	MODEL NO.	PAGE NO.	MODEL NO.	PAGE NO.
A16-0206-C	F9	J16-1001-SQ	F13	J74-4725	F15				
A24-0206-C	F9	J16-1250-RD	F13	J77-4401	F9				
A24-0207-C	F10	J16-1250-SQ	F13	J77-4420	F9				
B29-0080	F17	J16-1500-RD	F13	J79-4115	F9				
B70-1001	F6	J16-1500-SQ	F13	J80-5107-6-C	F12				
B70-1001-6	F6	J16-1625-RD	F13	J80-5109-6-C	F12				
B70-1002	F6	J16-2125-RD	F13	J81-5206-6-C	F12				
B70-1003	F6	J17-4270	F4	J81-5207-6-C	F12				
B70-1005	F6	J17-4273	F4	J81-5209-6-C	F12				
B70-1007	F6	J18-2000	F4	J86-4300	F12				
B70-1008	F6	J19-1400	F2	J86-4301	F12				
B74-0011	F6	J19-4955	F2, F4	J92-1000	F14				
B79-1000	F6	J19-4960	F2, F3	J92-5000	F14				
B79-1038	F6	J19-4960-LT	F3	J92-9360	F14				
B79-2000-L	F6	J19-4962	F3	J95-2187	F9				
B79-2000-R	F6	J19-4964	F3	J95-2250	F9				
B79-2038-L	F6	J19-4966	F3	K22-3100	F14				
B79-2038-R	F6	J19-4967	F4	K30-1000	F14				
B79-X014	F6	J19-5000	F4	K30-1010	F14				
B80-0716	F17	J25-2100	F5	Q85-2004	F16				
C3200CV	F11	J25-2200	F5	Q85-200424	F16				
C3200CH	F11	J25-2300	F5	Q85-2016	F16				
C3200CF	F11	J29-4482	F5	Q85-201606	F16				
C3400CV	F11	J30-4465	F5	Q85-201612	F16				
C3400CH	F11	J32-X001	F13	Q85-2128	F16				
C3400CF	F11	J32-X002	F13	Q85-212804	F16				
C3500CV	F11	J33-1532	F13	Q85-7000	F16				
C3500CH	F11	J52-0014	F10	Q85-7500	F16				
C3500CF	F11	J52-1250	F10	Q85-8000	F16				
G10-6550	F19	J53-0125	F10	Q85-8500	F16				
G12-6550	F19	J54-1580	F10	SIS-1000	F14				
G12-X001	F19	J54-1583	F10	SIS-6400	F14				
G22-4310	F19	J57-7100	F10	T80-0485	F16				
G22-4320	F19	J57-7125	F10						
G27-1250	F19	J57-7150	F10						
G28-6491	F20	J57-7158	F10						
G30-6480	F20	J58-0014	F10						
G32-6470	F20	J58-0100	F10						
G34-6460	F20	J58-0158	F10						
G36-4370	F20	J60-2240	F8						
G38-5330	F20	J60-2260	F8						
G40-6451	F20	J60-2270	F8						
G40-6452	F20	J61-2470	F8						
G44-4360	F20	J62-0012	F8						
G46-4360	F20	J63-1451	F7						
G46-4361	F20	J63-1451-8	F7						
G48-0005	F20	J63-1451-9	F7						
G50-5420	F20	J63-1451-10	F7						
IR-1105	F17	J63-1651-84	F7						
IR-0312RD	F17	J63-1651-120	F7						
IR-0312HX	F17	J63-2651-78	F7						
IR-0375HX	F17	J63-2651-120	F7						
IR-1190	F17	J64-1450	F7						
IR-2112	F17	J64-1450-8	F7						
IR-2263	F17	J64-1450-9	F7						
J12-1402	F2	J64-1450-10	F7						
J12-1601	F2	J64-1651-78	F7						
J13-4488	F2	J64-1651-120	F7						
J14-0117	F2	J64-2651-84	F7						
J14-0119	F2	J64-2651-120	F7						
J16-0100	F2, F13	J65-4110	F8						
J16-0158	F2, F13	J70-4701	F15						
J16-0158-SPSS	F13	J70-4691	F15						
J16-0201	F2, F13	J70-4801	F15						
J16-0201-SP	F13	J72-4711	F15						
J16-0201-SPSS	F13	J72-4731	F15						
J16-1000-RD	F13	J74-4721	F15						
J16-1000-SQ	F13	J74-4723	F15						



**COMPONENT
HARDWARE**

1890 Swarthmore Avenue • PO Box 2020 • Lakewood • NJ 08701
Tel. 800-526-3694 • 732-363-4700 • Fax 732-364-8110
www.componenthardware.com

