

Distributed by :
MBH International Sales, Inc.



For More Information
Email : Sales@mbhny.com

EQUIPMENT LEGS AND ACCESSORIES



Alphabetical Index

DESCRIPTION	PAGE	DESCRIPTION	PAGE
A		L	
ACCESSORIES	A23 - A24	LEG ASSEMBLIES	A16 - A18
ALUMINUM LEGS	A19	LEG SOCKETS	A1, A2
APPLIANCE LEGS	A19 - A22	LEGS, APPLIANCE	A19 - A22
B		LEGS, EQUIPMENT	A8 - A15
BRACKETS, UNDERSHELF	A24	LEVELERS, FOOT	A24
BRACKETS, QUICK CORNERS	A23	M	
C		MOUNTING PLATES	A24
CLAMPS, SPRING	A24	O	
CROSS BRACE FITTINGS	A23	ORDER FORMS	
CORNER BRACKETS	A23	H FRAME ASSEMBLY	A18
E		STAINLESS STEEL LEG ASSEMBLIES	A17
EQUIPMENT LEGS	A8 - A15, A22	P	
ABS PLASTIC	A9	PLATES, MOUNTING	A24
ECONOLINE	A10	PLASTIC LEGS, EQUIPMENT	A9
HEAVY- DUTY S/S	A11 - A15	S	
EXTRA WIDE, STAINLESS CLAD	A15	SECURITY LEGS	A8
SEISMIC/SECURITY	A8	SHELF SUPPORTS	A1
F		SOCKETS, LEG	A1, A2
FITTINGS, CROSS BRACE	A23	SPRING CLAMPS	A24
FOOT INSERTS, ADJUSTABLE	A3 - A7	T	
FLANGED	A7	THREAD CONVERTER	A21
STAINLESS CLAD PLASTIC	A4	U	
SEISMIC RESTRAINT	A4	UNDERSHELF BRACKETS	A24
FOOT LEVELERS	A24	H	
FORMED METAL LEGS	A16	HOLE PLUG	A24
H		HI-RISE® ADJUSTABLE FOOT INSERTS	A5
HOLE PLUG	A24	H-FRAME ASSEMBLY	A18
HI-RISE® ADJUSTABLE FOOT INSERTS	A5		
H-FRAME ASSEMBLY	A18		

Component Hardware Group is a proud member of the following organizations



Products shown in this catalog may be listed and/or certified by one or more of the following regulatory agencies and will be designated by the following marks



All photographs and illustrations are considered to be a representation of the actual item. In some cases there may be slight variations. This catalog, copy, part numbers and unique method of illustrating products is copyrighted by Component Hardware Group, Inc. All rights reserved. No portion of this catalog may be reproduced in any form or by any means in whole or in part, without the written consent of Component Hardware. Component Hardware reserves the right to make any and all changes and to discontinue any of its products without notice.

Not responsible for typographical errors.

© COPYRIGHT 2018 COMPONENT HARDWARE GROUP, INC.

#CAT-X021 2/2018 PRINTED IN U.S.A.

Leg Sockets & Shelf Supports

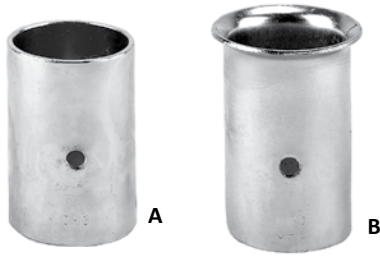

ZINC PLATED STEEL LEG SOCKETS

- STRAIGHT OR FLARED MODELS AVAILABLE
- LOCKING SET SCREW PROVIDED FOR SECURE ASSEMBLY
- PERMITS KD SHIPPING

REF.	MODEL NO.	HEIGHT	MATERIAL	APPLICATION
B	A26-0207-C	3" (76mm)	ZINC PLATED	1-5/8" (41mm) O.D. TUBING
A	A28-0207-C	2-5/8" (66mm)	ZINC PLATED	1-1/4" (32mm) IPS PIPE

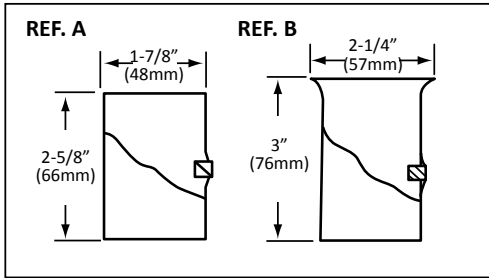

STAINLESS STEEL TUBULAR SHELF SUPPORTS

FOR 1-5/8" (41mm) O.D. TUBING

- LONG AND SHORT LENGTH MODELS AVAILABLE
- FURNISHED WITH LOCKING SET SCREWS
- CAN BE USED AS ADJUSTABLE POT RACK BAND SUPPORT



REF.	MODEL NO.	HEIGHT	APPLICATION
C	A24-0206-C	1-7/8" (48mm)	1-5/8" (41mm) O.D. TUBING
D	A24-0207-C	5-1/4" (133mm)	1-5/8" (41mm) O.D. TUBING

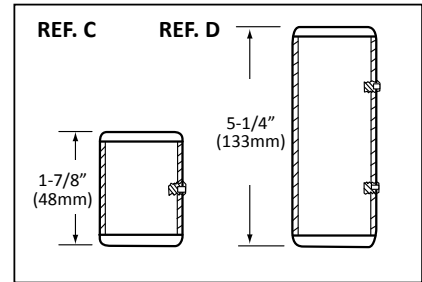

16 GAUGE ALL STAINLESS STEEL LEG SOCKET

- UNIQUE INTERIOR GEOMETRY TIGHTLY FITS THE DIAMETER OF THE LEG
- INCREASED SURFACE CONTACT IMPROVES STABILITY
 - 2" OUTSIDE DIAMETER FOR 1-5/8" OD TUBING
 - SATIN STAINLESS STEEL FINISH
 - FLANGED TOP FOR EASE OF WELDING
- PERMITS KD SHIPPING TO REDUCE FREIGHT COSTS
- LOCKING SET SCREW ENSURES SECURE ASSEMBLY

MODEL NO. A19-1000

PATENT PENDING

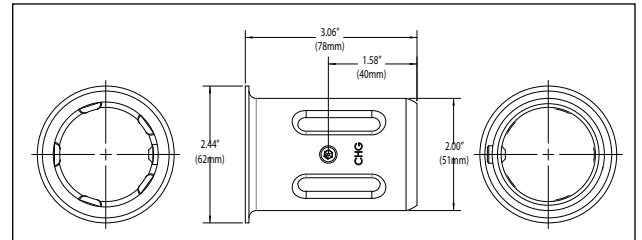

TYPE 304 STAINLESS STEEL TRIANGULAR MOUNTING PLATE

- 14-GA. THICK

MODEL NO. LSB-158

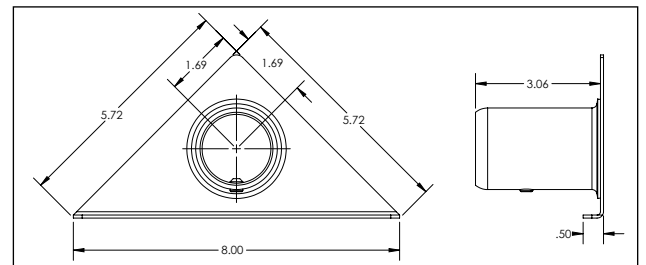

NSF STANDARDS GOVERNING THE USE OF SET SCREWS IN NON-FOOD ZONES REQUIRE THE PLUGGING OF THE HEX SOCKET HOLE AFTER FINAL ASSEMBLY AND TIGHTENING. THIS MAY BE ACCOMPLISHED BY APPLYING A HARDEENING TYPE SILICONE SEALANT OR THE USE OF A HOLE PLUG. STANDARD NSF TYPE PUSH-IN PLASTIC HOLE PLUGS ARE AVAILABLE. SPECIFY A10-0020 WHEN ORDERING, SEE PAGE A24. ADDITIONAL 5/16-24 SET SCREWS ARE AVAILABLE. SPECIFY A18-X001 WHEN ORDERING.

Stainless Steel Leg Sockets



STAINLESS STEEL LEG SOCKETS



- FOR 1-1/2" & 1-5/8" O.D. LEG ASSEMBLIES
 - CONSTRUCTED OF 16 ga (1.5mm) STAINLESS STEEL TUBING
- PROVIDED WITH LOCKING SET SCREW TO ASSURE SECURE ASSEMBLY
- MODELS AVAILABLE WITH PLAIN OR FLARED TOP FOR WELD ON APPLICATIONS OR WELDED STAINLESS STEEL MOUNTING PLATES
 - PERMITS KD SHIPPING

REF.	MODEL NO.	HEIGHT	APPLICATION	DIA.
A	A16-0206-C	1-3/4" (44mm)		
C*	A18-0203-C	3-1/4" (82mm)		
B	A18-0206-C	3-1/16" (78mm)	1-5/8" (41mm)	2" (51mm)
E	A18-0406-C	3-1/8" (79mm)	O.D. TUBING or 1-1/4" I.P.S. PIPE	
B**	A18-9900-C	3-1/16" (78mm)		
D	A20-0206-C	3-1/2" (89mm)		
F	A20-0406-C	3-9/16" (90mm)		
G	A18-0202-C	2-7/16" (62mm)	1-1/2" (38mm)	1-3/4" (44mm)
E	A18-0402-C	2-1/2" (64mm)	O.D. TUBING	

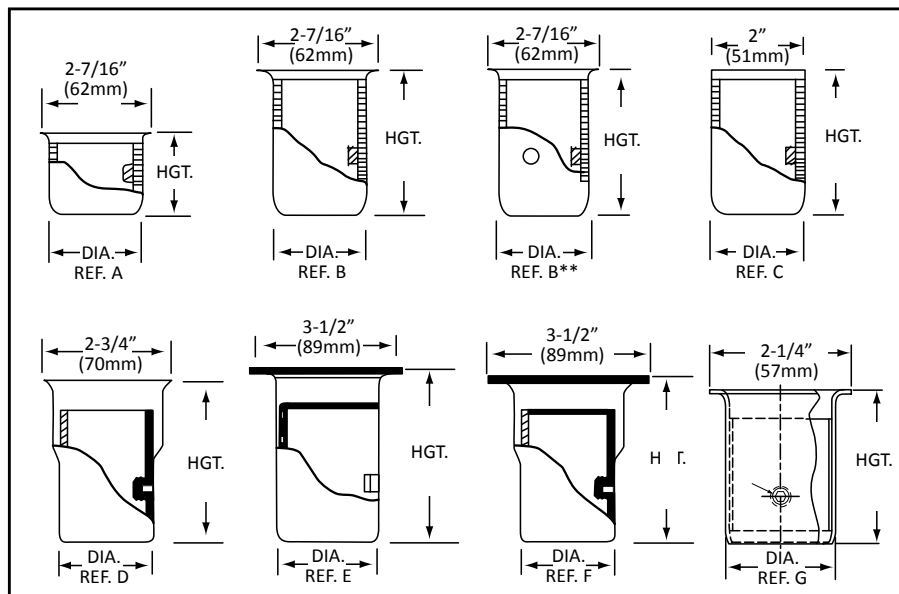

*FURNISHED WITHOUT FLARED TOP **FURNISHED WITH 2 SET SCREWS. MOUNTING PLATE HAS (4) 5/16" (8mm) DIA. HOLES ON 2-5/8" (66mm) CENTERS. NSF STANDARDS GOVERNING THE USE OF SET SCREWS IN NON-FOOD ZONES REQUIRES THE PLUGGING OF THE HEX SOCKET HOLE AFTER FINAL ASSEMBLY AND TIGHTENING. THIS MAY BE ACCOMPLISHED BY APPLYING A HARDENING TYPE SILICONE SEALANT OR THE USE OF A HOLE PLUG. STANDARD NSF TYPE PUSH-IN PLASTIC HOLE PLUGS ARE AVAILABLE. SPECIFY A10-0020 WHEN ORDERING, SEE PAGE A24. ADDITIONAL 5/16-24 SET SCREWS ARE AVAILABLE. SPECIFY A18-X001 WHEN ORDERING.

ADJUSTABLE FOOT INSERTS FOR ROUND TUBING

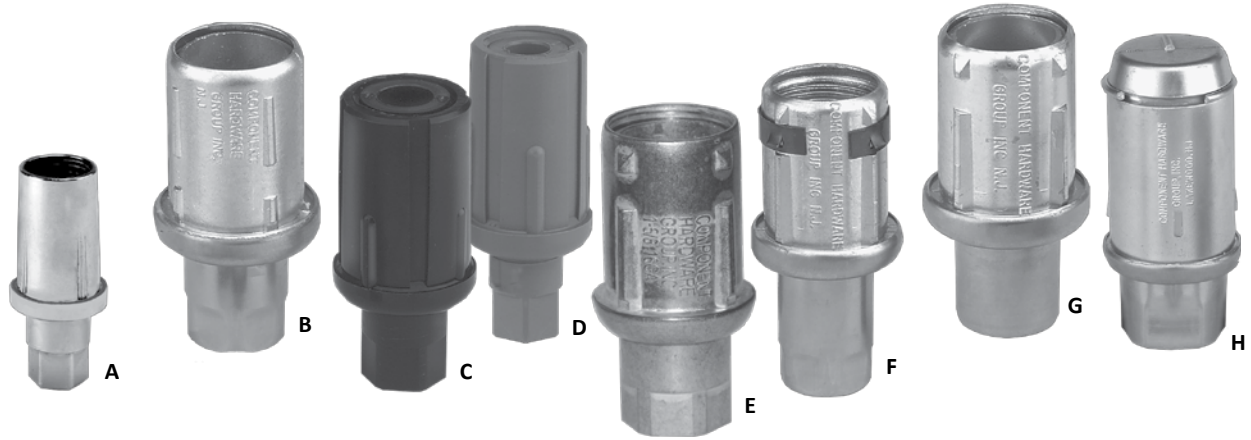

CONVENTIONAL ROUND & HEX ADJUSTABLE TOES FOR ROUND TUBING AND PIPE

AVAILABLE IN:

- NATURAL FINISH ZAMAK • NICKEL PLATED ZAMAK
- THERMOPLASTIC, GRAY OR BLACK • STAINLESS STEEL CLAD
- ADJUSTABLE TO LEVEL EQUIPMENT ON JOB SITE
- MOST TOES SUPPLIED WITH WRENCH FLATS FOR EASY ADJUSTMENT

REF.	MODEL NO.	FOOT DESCRIPTION	TYPE	HEIGHT	ADJ.	LOAD RATING	APPLICATION
A	A10-0221-C	NICKEL PLATED ZAMAK	HEX	1 1/16" (18mm)	13/16" (21mm)	1100 (500)	1" (25mm) O.D. TUBING 16 ga (1.5mm) & 18 ga (1.2mm)
A	A10-0421-C	NICKEL PLATED ZAMAK	HEX	3/4" (19mm)	1-1/8" (28mm)	1400 (635)	1-1/4" (32mm) O.D. TUBING 16 ga (1.5mm)
B	A10-0611-C	NATURAL FINISH ZAMAK	HEX	1-1/4" (32mm)	1-1/8" (28mm)	2000 (900)	
B	A10-0651-C	STAINLESS STEEL CLAD	HEX	1-1/2" (38mm)	1-1/4" (32mm)	2000 (900)	1-1/2" (38mm) O.D. TUBING 16 ga (1.5mm)
C	A10-0631-C	THERMOPLASTIC BLACK	HEX	1-3/8" (35mm)	1-1/16" (27mm)	200 (90)	or 1-1/4" I.P.S. PIPE
D	A10-0641-C	THERMOPLASTIC GRAY	HEX	1-3/8" (35mm)	1-1/16" (27mm)	200 (90)	
E	A10-0811-C	NATURAL FINISH ZAMAK	HEX	1-1/4" (32mm)	1-1/8" (28mm)	2000 (900)	
F*	A10-0851-C	STAINLESS STEEL CLAD	HEX	1-1/2" (38mm)	1-1/4" (32mm)	2000 (900)	
G	A10-0852-C	STAINLESS STEEL CLAD	ROUND	1-1/2" (38mm)	1-1/4" (32mm)	2000 (900)	1-5/8" (41mm) O.D. TUBING 16 ga (1.5mm)
C	A10-0831-C	THERMOPLASTIC BLACK	HEX	1-3/8" (35mm)	1-1/16" (27mm)	200 (90)	
D	A10-0841-C	THERMOPLASTIC GRAY	HEX	1-3/8" (35mm)	1-1/16" (27mm)	200 (90)	
H	A11-0851-C	STAINLESS STEEL CLAD	HEX	1" (25mm)	2" (51mm)	2300 (1040)	2" (52mm) O.D. TUBING 16 ga (1.5mm)

* SHOWN WITH OPTIONAL POSI-GRIP LOCKING RING



*OPTIONAL POSI-GRIP LOCKING RING

MODEL NO. A10-0010-C

SPRING STEEL WITH CLEATS THAT GRIP AND BITE TUBING TO LOCK FOOT TO TUBE.

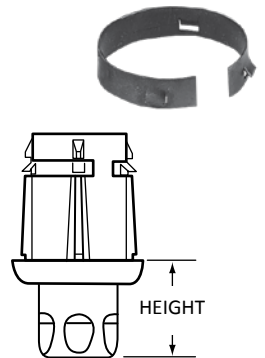

Seismic Restraint and Engineered Plastic Adjustable Foot Inserts

STAINLESS STEEL CLAD PLASTIC ADJUSTABLE FOOT INSERT

FOR 1-1/2"(38mm) AND 1-5/8" (41mm) ROUND TUBING



- STAINLESS STEEL CLAD TOE • ECONOMICAL • OFFERS A FULL 1-1/4" (32mm) ADJUSTMENT
- WRENCH FLATS AND UNIQUE THREADING OFFERS SMOOTH, FAST FIELD ADJUSTMENT
- EACH MODEL DESIGNED TO SUIT EITHER 16 ga (2mm) OR 18 ga (1mm) ROUND TUBING
- SPECIALLY DESIGNED ENGINEERED PLASTIC CONSTRUCTION WITHSTANDS TODAY'S HARSH CHEMICAL CLEANSERS IN COMMERCIAL KITCHEN ENVIRONMENTS

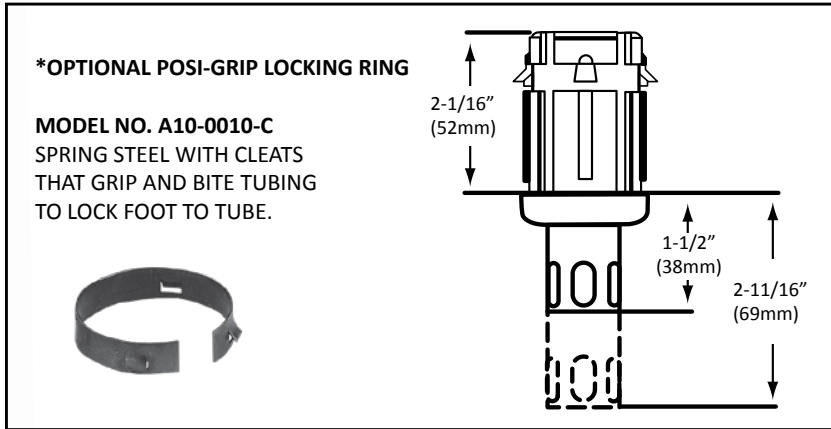

MODEL NO.	APPLICATION	TYPE	HEIGHT	ADJ.	LOAD RATING
A10-1000	1-5/8" (41mm) O.D Tubing 16 ga (1.5mm) & 18 ga (1.2mm)	HEX	1-1/2" (38mm)	1-1/4" (32mm)	1000 lbs (450 kg)
A10-1500	1-1/2"(38mm) O.D Tubing 16 ga (1.5mm) & 18 ga (1.2mm)	HEX	1-1/2" (38mm)	1-1/4" (32mm)	1000 lbs (450 kg)

ADJUSTABLE SEISMIC RESTRAINT FOOT

MODEL NO. A10-0852-S

- 7/16" DIA. (.44mm) HOLE IN BOTTOM OF TOE TO PERMIT SECURE ANCHORING TO REBAR IN FLOOR
- MEETS SMACNA GUIDELINES FOR SEISMIC RESTRAINT OF EQUIPMENT
- STAINLESS STEEL CLAD ZAMAK CONSTRUCTION WILL NOT CORRODE
- FOR 1-5/8" O.D. (41mm), 16 GAUGE (1.5mm) TUBING APPLICATIONS
- ADJUSTABLE ROUND TOE PERMITS 1-1/4" (32mm) HEIGHT ADJUSTMENT
 - STATIC LOAD RATING TO 2000LBS (900kg)
- AVAILABLE WITH OPTIONAL POSI-GRIP LOCKING RING FOR ADDED PULL-OUT STRENGTH



7/16" (.44mm)
DIA. OPENING

*OPTIONAL POSI-GRIP LOCKING RING

MODEL NO. A10-0010-C
 SPRING STEEL WITH CLEATS THAT GRIP AND BITE TUBING TO LOCK FOOT TO TUBE.

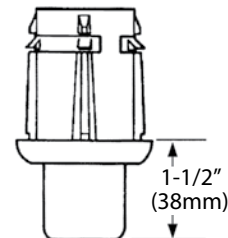

Adjustable Foot Insert Features Full 3" Adjustment

HI-RISE[®] ADJUSTABLE FOOT INSERTS

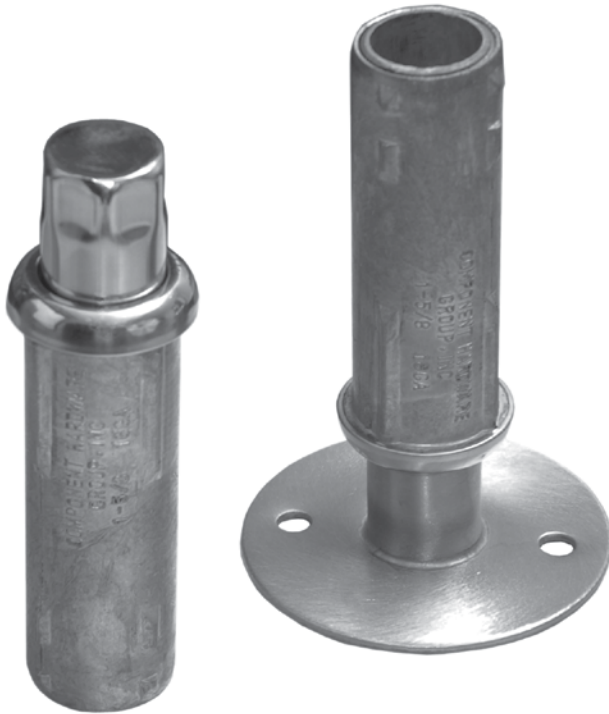

- FULL 3" (76mm) HEIGHT ADJUSTMENT
- RUGGED 2000 lbs STATIC LOAD RATING
- STAINLESS STEEL FLANGED MODELS AVAILABLE
 - IDEAL FOR LENGTHY CAFETERIA LINES AND COUNTERS WHERE FLOOR PITCH IS A CONCERN
 - ELIMINATES COSTLY FIELD MODIFICATION
- MAXIMUM HEIGHT ADJUSTMENT HELPS AVOID PLUMBING OBSTACLES AND OTHER UNFORESEEN CONDITIONS DURING INSTALLATION OF EQUIPMENT

Adjustable Foot Inserts, specified by Engineers and Consultants, are specifically designed to meet pending OSHA requirements which suggest maximum counter and table adjustments to permit comfortable working environments.



3" (76mm) ADJUSTABLE FOOT INSERT TO SUIT 1-5/8" (41mm) O.D. TUBING 16 ga (1.5mm)

MODEL NO.	DESCRIPTION	TYPE	HEIGHT	ADJ.	LOAD RATING
A10-0881-C	STAINLESS STEEL	HEX	1-1/2" (38mm)	3" (76mm)	2000 lbs (900 kg)
A10-0884-C	S/S FLANGED W/ (2) 11/32" (9mm) DIA. MOUNTING HOLES	FLANGED	1-1/2" (38mm)	3" (76mm)	2000 lbs (900 kg)

*OPTIONAL POSI-GRIP LOCKING RING

MODEL NO. A10-0010-C

SPRING STEEL WITH CLEATS THAT GRIP AND BITE TUBING TO LOCK FOOT TO TUBE.

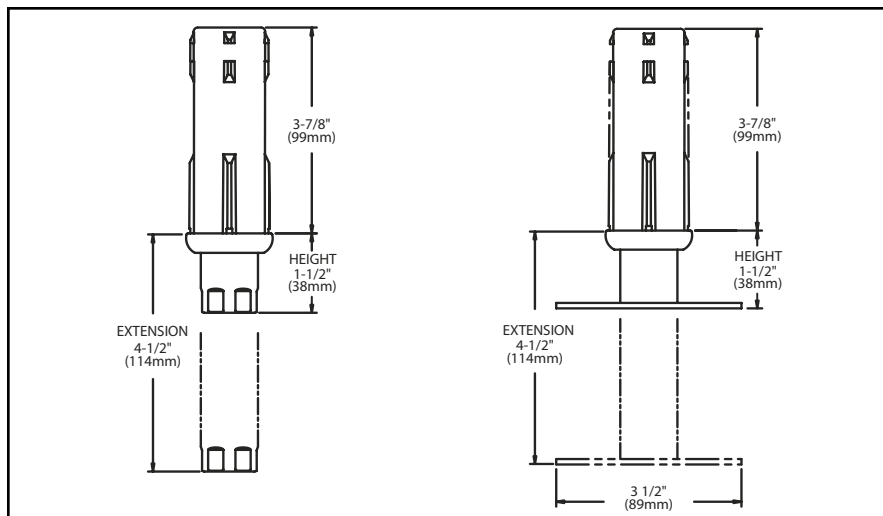
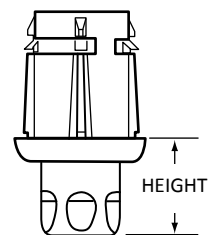

Foot Inserts For Square Tubing

ADJUSTABLE FOOT INSERTS FOR SQUARE TUBING

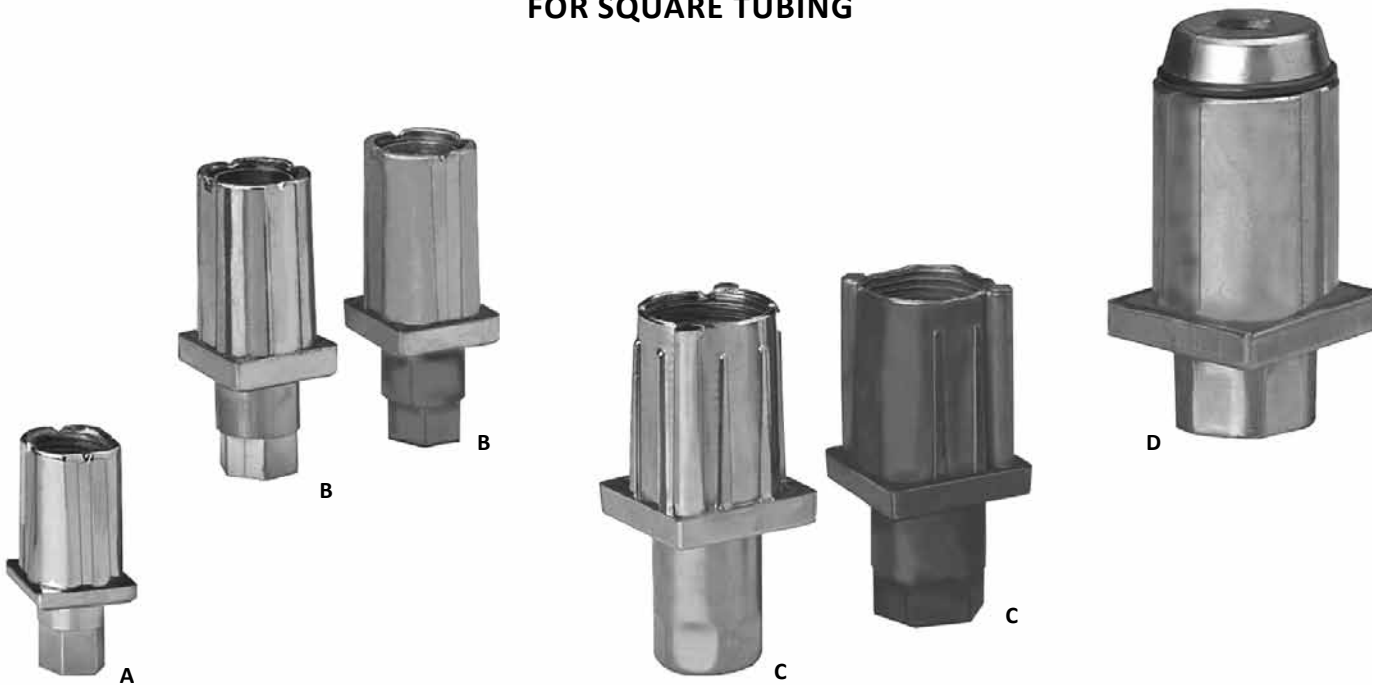

- AVAILABLE WITH ZINC, NICKEL OR STAINLESS STEEL CLAD FINISH
- ADJUSTABLE TO LEVEL EQUIPMENT ON JOB SITE
 - WRENCH FLATS FOR EASY ADJUSTMENT
- 2" (51mm) MODEL COMPLETE WITH RETAINING RING AND HEAVY-DUTY CONSTRUCTION

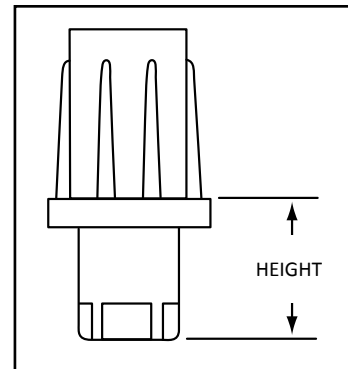

REF.	MODEL NO.	FOOT DESCRIPTION	TYPE	HEIGHT	ADJ.	LOAD RATING	APPLICATION
A	A14-0221-C	NICKEL PLATED ZAMAK	HEX	11/16" (18mm)	7/8" (22mm)	1200 (550)	1" (25mm) SQ. TUBING 16 ga (1.5mm) or 18 ga (1.2mm)
B	A14-0411-C	NATURAL FINISH ZAMAK	HEX	1-1/4" (32mm)	1-1/8" (28mm)	2000 (900)	1-1/4" (32mm) SQ. TUBING 16 ga (1.5mm) or 18 ga (1.2mm)
	A14-0421-C	NICKEL PLATED ZAMAK	HEX	1-3/8" (35mm)	1" (25mm)	2000 (900)	1-1/4" (32mm) SQ. TUBING 16 ga (1.5mm) or 18 ga (1.2mm)
C	A14-0611-C	NATURAL FINISH ZAMAK	HEX	1-1/4" (32mm)	1-1/8" (28mm)	2000 (900)	1-1/2" (38mm) SQ. TUBING 16 ga (1.5mm) or 18 ga (1.2mm)
	A14-0651-C	STAINLESS STEEL CLAD	HEX	1-1/2" (38mm)	1-1/8" (28mm)	2000 (900)	1-1/2" (38mm) SQ. TUBING 16 ga (1.5mm) or 18 ga (1.2mm)
D	A15-0851-C	STAINLESS STEEL CLAD	HEX	1" (25mm)	2" (51mm)	2300 (1040)	2" (51mm) SQ. TUBING 16 ga (1.5mm)

Flanged Foot Inserts For Round & Square Tubing

FLANGED ADJUSTABLE FOOT INSERTS FOR ROUND OR SQUARE TUBING OR PIPE



- AVAILABLE WITH STAINLESS STEEL CLAD OR NICKEL PLATED FINISH
- AVAILABLE WITH OR WITHOUT MOUNTING HOLES
- ADJUSTABLE TO LEVEL EQUIPMENT ON JOB SITE
- REDUCED FLANGE MODELS AVAILABLE

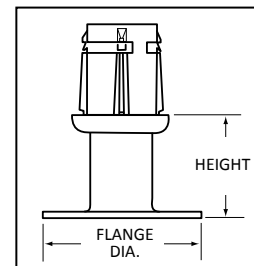

NOTE: Ref. D and E shown with optional posi-grip locking rings

REF.	MODEL NO.	FLANGE DESCRIPTION	HEIGHT	ADJ.	LOAD RATING Lbs/Ft (Kg/mm)	APPLICATION
A	A14-0224-C	1-3/16" (30mm) DIA. NICKEL PLATED ZAMAK	3/4" (17.5mm)	1/2" (12mm)	1200 (550)	1"(25mm) SQUARE TUBING 16 ga (1.5mm) & 18 ga (1.2mm)
B	A14-0424-C	2-1/8" (54mm) NICKEL PLATED zamak	1-3/8" (35mm)	1" (25mm)	2000 (900)	1-1/4"(32mm) SQUARE TUBING 16 ga (1.5mm) OR 18 ga (1.2mm)
D*	A10-0654-C	3-1/2" (89mm) DIA. S/S WITH MOUNTING HOLES**	1-1/2" (38mm)	1-1/8" (28mm)	2000 (900)	1-1/4" I.P.S. PIPE OR 1-1/2"(38mm) O.D. ROUND TUBING 16 ga (1.5mm)
C*	A14-0653-C	3-1/2" (89mm) DIA. S/S NO MOUNTING HOLES	1-1/2" (38mm)	1-1/8" (28mm)	2000 (900)	1-1/2"(38mm) SQUARE TUBING 16 ga (1.5mm) OR 18 ga (1.2mm)
C*	A14-0654-C	3-1/2" (89mm) DIA. S/S WITH MOUNTING HOLES**	1-1/2" (38mm)	1-1/8" (28mm)	2000 (900)	
E	A10-9904-C	2" (50mm) DIA. S/S NO MOUNTING HOLES	1-1/2" (38mm)	1-1/8" (28mm)	2000 (900)	1-5/8"(41mm) O.D. ROUND TUBING FOR MARINE APPLICATION 16 ga (1.5mm)
D*	A10-0853-C	3-1/2" (89mm) DIA. S/S NO MOUNTING HOLES	1-1/2" (38mm)	1-1/8" (28mm)	2000 (900)	1-5/8"(41mm) O.D. ROUND TUBING 16 ga (1.5mm)
D*	A10-0854-C	3-1/2" (89mm) DIA. S/S WITH MOUNTING HOLES**	1-1/2" (38mm)	1-1/8" (28mm)	2000 (900)	
F*	A11-0854-C	3-1/2" (89mm) DIA. S/S WITH MOUNTING HOLES**	1" (25mm)	2" (51mm)	2300 (1040)	2"(51mm) O.D. ROUND TUBING 16 ga (1.5mm)
G*	A15-0854-C	3-1/2" (89mm) DIA. S/S WITH MOUNTING HOLES**	1" (25mm)	2" (51mm)	2300 (1040)	2"(51mm) SQUARE TUBING 16 ga (1.5mm) OR 18 ga (1.2mm)

* Flanged Foot Models Have 12 GA. (2.6mm) Stainless Steel Flange With A #4 Satin Finish.

** Provided With (2) 11/32" (9mm) DIA. Mounting Holes, Spaced 2-1/2" (64mm) O.C.

Security /Seismic Heavy-Duty Leg Assemblies

SECURITY/SEISMIC EQUIPMENT LEGS STAINLESS STEEL

- THREADED STEEL STUD OR WELDED MOUNTING PLATE PROVIDED FOR EASY MOUNTING OF LEGS TO EQUIPMENT
 - FOOT INSERTS ARE PROVIDED WITH A 3-1/2" (89mm) DIA. 11 ga (3mm) FLANGE
- ALL LEGS MAY BE FURNISHED TO MEET SPECIFIC REQUIREMENTS WITH SPECIAL STUDS AND/OR MOUNTING PLATES
- LEGS MAY BE FURNISHED IN SETS OF FOUR WITH CUSTOMER'S PART NUMBERS FOR KD SHIPPING
 - MOUNTING PLATE HAS (4) 5/16" (8mm) DIA. MOUNTING HOLES ON 2-5/8" CENTERS



FLOOR FASTENED • STAINLESS STEEL SECURITY/SEISMIC EQUIPMENT LEGS

MODEL NO.	DESCRIPTION
A47-9932-C	1-5/8" (41mm) O.D. WITH WELDED MOUNTING PLATE
A50-9939-C	1-5/8" (41mm) O.D. WITH 1/2-13 PROTRUDING STUD
A88-9902-C	2" (51mm) O.D. WITH WELDED MOUNTING PLATE
A90-9902-C	2" (51mm) O.D. WITH 3/4-10 PROTRUDING STUD

Easily modified to meet SMACNA seismic restraint requirements. First, drill a 5/8" (16mm) diameter hole in flanged toe to accommodate anchored floor rod. Then, simply drill a 1/4" (6mm) diameter horizontal hole through toe portion which allows leg to be pinned to anchored rod. (Pin not furnished)

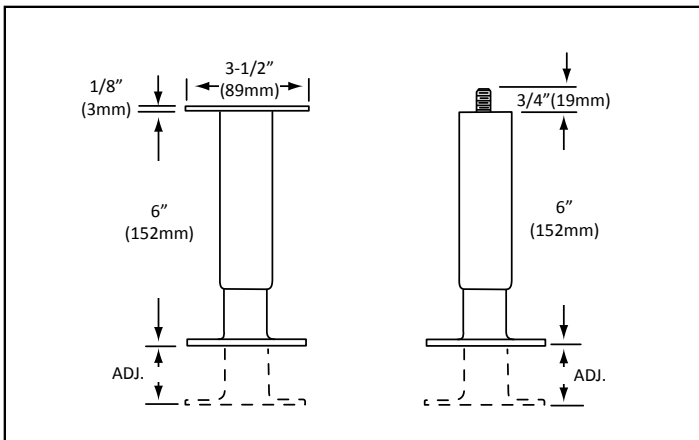
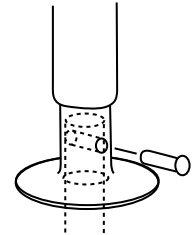

SPECIFICATIONS

MATERIAL: 1-5/8" (41mm) AND 2" (51mm) O.D. STAINLESS STEEL TUBING

FINISH: #4 SATIN FINISH

TOE ADJUSTMENT: LEGS ARE 6" (152mm) IN HEIGHT AND PROVIDE 1-1/2" (38mm) ADJUSTMENT

STATIC LOAD RATING: 2,000 lbs (900kg) PER LEG

Security/Seismic Equipment Legs are specifically designed for Marine, Prison and Institutional applications where installations require Secured Floor-Fastened Adjustable Legs on equipment that may be subjected to sudden movement or shifting. Equipment Legs are available in both 1-5/8" (41mm) and 2" (51mm) O.D. models with a protruding threaded stud or welded 3-1/2" (89mm) 11 gauge (3mm) square mounting plate. The 3-1/2" (89mm) dia. flanged foot has two 11/32" (9mm) dia. floor fastening holes on 2-1/2" (63mm) centers.

HIGH IMPACT ABS PLASTIC EQUIPMENT LEGS



FOR ICE MAKERS, REACH-INS, COMMERCIAL REFRIGERATORS, COUNTERS & COMMERCIAL CABINETS

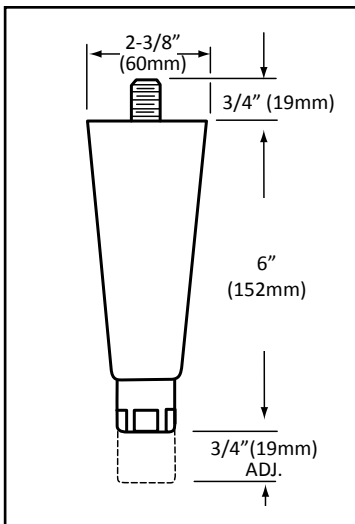

- 2000 lbs (900 kg) PER LEG STATIC LOAD RATING
 - BLACK MATTE FINISH
- TOUGH, DURABLE, HIGH IMPACT RESISTANT ABS PLASTIC BODY
- AVAILABLE WITH NON-REMOVABLE METAL TOE WITH NON-MARRING ABS PLASTIC BASE OR BLACK ABS NON-MARRING TOE
 - FULLY ADJUSTABLE TOE
- WRENCH FLATS ON TOE FOR EASY ADJUSTMENT
- 6" MINIMUM HEIGHT WITH ADJUSTABLE TOE
- CORROSION RESISTANT ZINC PLATING ON ALL STUDS

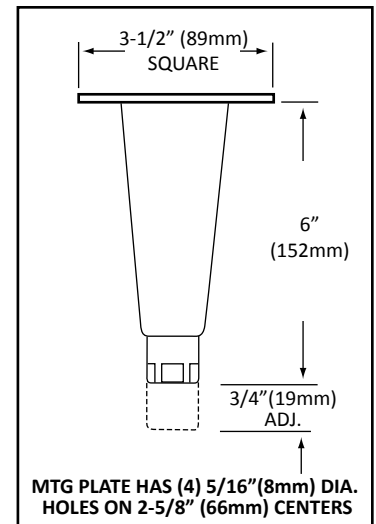

ABS PLASTIC EQUIPMENT LEGS

MODEL NO.	MOUNTING TYPE	LEG COLOR	FOOT TYPE
AP63-2003-C	1/2 - 13 FLUSH STUD WITH 3-1/2" SQUARE MOUNTING PLATE	BLACK	BLACK
AP61-4003-C	1/2 - 13 PROTRUDING STUD	BLACK	NICKEL PLATED ZAMAK
AP62-4003-C	5/8 - 11 PROTRUDING STUD	BLACK	NICKEL PLATED ZAMAK
AP63-4003-C	1/2 - 13 FLUSH STUD WITH 3-1/2" SQUARE MOUNTING PLATE	BLACK	NICKEL PLATED ZAMAK
AP64-4003-C*	1/2 - 13 FLUSH STUD WITH 2-1/2 x 3-5/8" RECTANGULAR NON-REMOVABLE MOUNTING PLATE	BLACK	NICKEL PLATED ZAMAK

* NON-STOCK ITEM, SEE PG A24 FOR MOUNTING PLATE DETAILS

Economy Zinc Die Cast Equipment Legs

ECONOLINE EQUIPMENT LEGS DIE CAST ZAMAK

- THREADED STEEL STUD OR REMOVABLE MOUNTING PLATE PROVIDED FOR EASY MOUNTING OF LEGS TO EQUIPMENT
- FOOT INSERTS ARE HEX SHAPED TO PERMIT QUICK HEIGHT ADJUSTMENT
- ALL LEGS MAY BE FURNISHED TO MEET SPECIFIC REQUIREMENTS WITH SPECIAL STUDS AND/OR MOUNTING PLATES
- LEGS MAY BE FURNISHED PACKAGED IN SETS OF FOUR WITH CUSTOMER'S PART NUMBER AS AN OPTION FOR KD SHIPPING



Available in finishes of...

- NICKEL, BLACK EPOXY, GRAY EPOXY
- DURABLE, CHIP-RESISTANT FINISH
- REMOVABLE MOUNTING PLATE or PROTRUDING STUD
- WRENCH FLATS ON TOE FOR EASY ADJUSTMENT

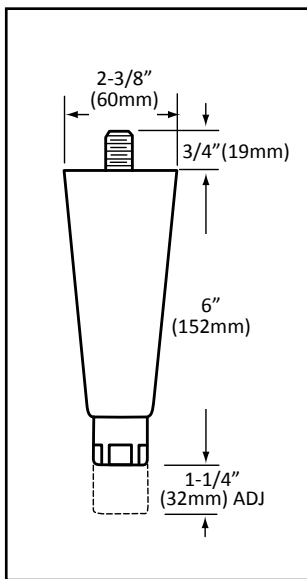

ECONOLINE DIE CAST EQUIPMENT LEGS

MODEL NO.	MOUNTING TYPE	LEG FINISH	FOOT TYPE
AE61-2003-C*		BLACK EPOXY	HEX
AE61-2104-C	FURNISHED WITH 1/2-13	GRAY EPOXY	HEX
AE61-4002-C	PROTRUDING STUD	NICKEL	HEX
AE61-5002-C		NICKEL	S/S HEX
AE62-4002-C	FURNISHED WITH 5/8-11	NICKEL	HEX
AE62-2104-C	PROTRUDING STUD	GRAY EPOXY	HEX
AE62-5002-C		NICKEL	S/S HEX
AE63-2003-C	FURNISHED WITH 1/2-13 FLUSH STUD	BLACK EPOXY	HEX
AE63-4002-C	W/ 3-1/2" SQUARE REMOVABLE MOUNTING PLATE**	NICKEL	HEX
AE63-2104-C*		GRAY EPOXY	HEX
AE63-5002-C		NICKEL	S/S HEX

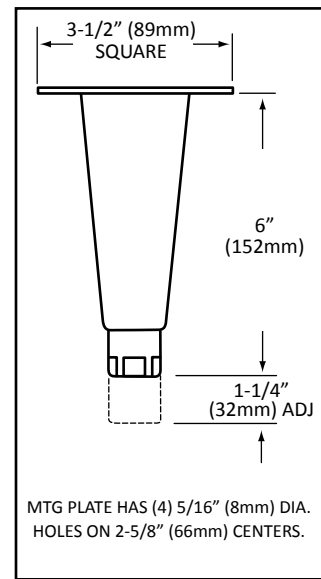

* NON-STOCK ITEM, SEE PAGE A24 FOR MOUNTING PLATE DETAILS

SPECIFICATIONS

- MATERIAL:** DIE CAST ZAMAK CONSTRUCTION
- TOE ADJUSTMENT:** LEGS ARE 6" (152mm) IN HEIGHT AND PROVIDE 1-1/4" (32mm) ADJUSTMENT
- STATIC LOAD RATING:** 2000 lbs (900 kg) PER LEG

HEAVY-DUTY STAINLESS STEEL EQUIPMENT LEGS

- THREADED STEEL STUD OR REMOVABLE MOUNTING PLATE PROVIDED FOR EASY MOUNTING OF LEGS TO EQUIPMENT
- ALL LEGS MAY BE FURNISHED TO MEET SPECIFIC REQUIREMENTS WITH SPECIAL STUDS AND /OR MOUNTING PLATES
- LEGS MAY BE FURNISHED PACKAGED IN SETS OF FOUR WITH CUSTOMER'S PART NUMBER FOR KD SHIPPING

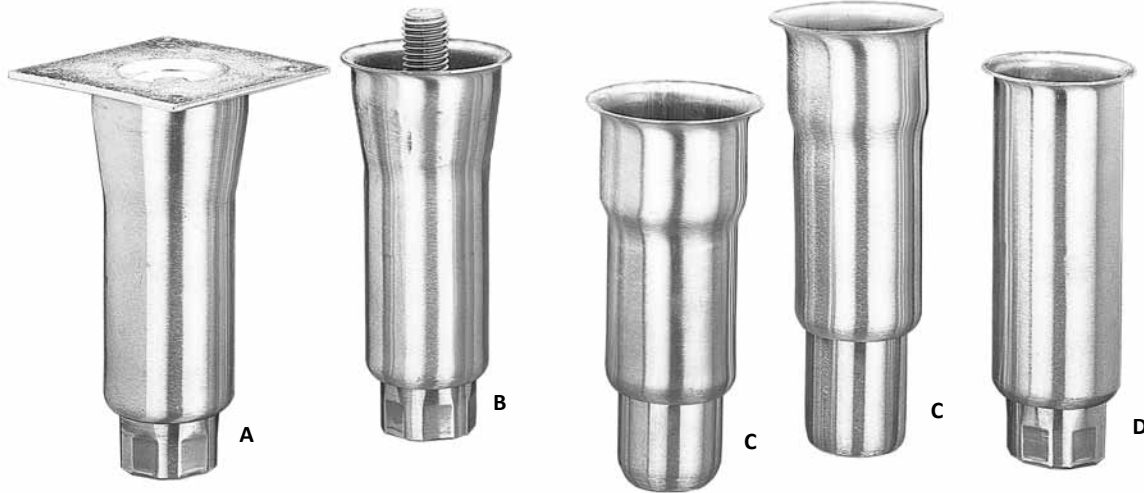

HEAVY-DUTY STAINLESS STEEL 2" (51mm) O.D. EQUIPMENT LEGS

- TAPERED BODY with LARGE FLARED TOP
- REMOVABLE MOUNTING PLATE
- FLUSH or PROTRUDING MOUNTING STUD

REF.	MODEL NO.	DESCRIPTION	FOOT	HEIGHT	ADJ.
A	A77-5048-C	FURN. WITH REMOVABLE MOUNTING PLATE	HEX	6" (152mm)	1-3/4" (44mm)
NOT SHOWN	A78-5048-C	FURN. WITH 3/4"-10 FLUSH STUD	HEX	6" (152mm)	1-3/4" (44mm)
B	A79-5048-C	FURN. WITH 3/4"-10 PROTRUDING STUD	HEX	6" (152mm)	1-3/4" (44mm)



HEAVY-DUTY STAINLESS STEEL 2" (51mm) O.D. EQUIPMENT LEGS for WELDED APPLICATIONS

- STEPPED SHAPE or STRAIGHT SHAPE with LARGE 2-3/8" (60mm) DIA. FLARED TOP

REF.	MODEL NO.	DESCRIPTION	FOOT	HEIGHT	ADJ.
C	A72-0811	STEPPED	ROUND	6" (152mm)	1-3/4" (44mm)
D	A52-9907-C	STRAIGHT	HEX	6" (152mm)	1-3/4" (44mm)

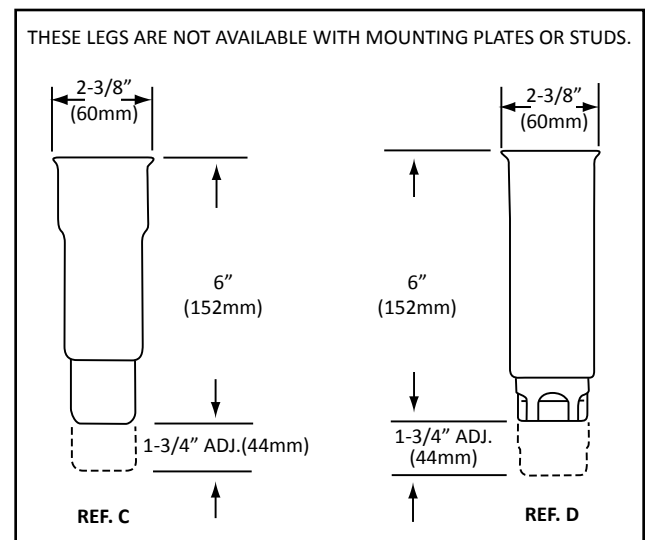
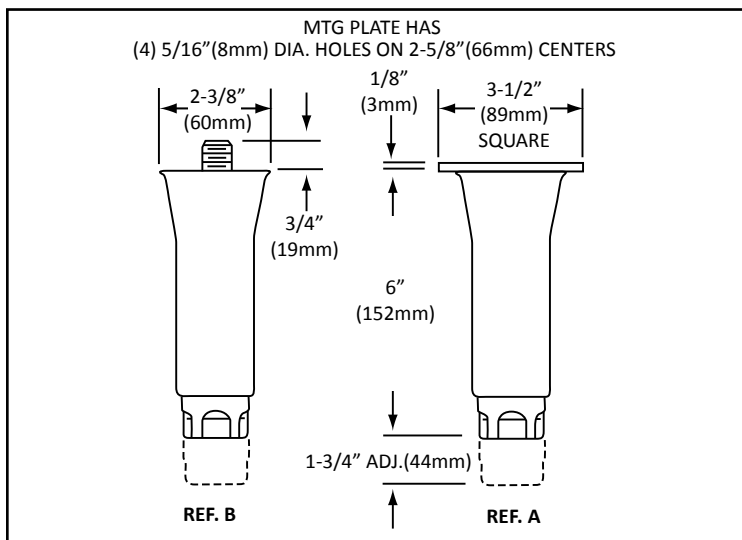

SPECIFICATIONS

MATERIAL: 2" (51mm) O.D. STAINLESS STEEL TUBING

FINISH: #4 FINISH

TOE ADJUSTMENT: LEGS ARE 6" (152mm) IN HEIGHT AND PROVIDE 1-3/4" (44mm) ADJUSTMENT

STATIC LOAD RATING: 2000 lbs (900 kg) PER LEG

Stainless Steel Equipment Legs

HEAVY-DUTY STAINLESS STEEL EQUIPMENT LEGS

- THREADED STEEL STUD OR REMOVABLE MOUNTING PLATE PROVIDED FOR EASY MOUNTING OF LEGS TO EQUIPMENT
 - FOOT INSERTS ARE HEX SHAPED TO PERMIT QUICK HEIGHT ADJUSTMENT
- ALL LEGS MAY BE FURNISHED TO MEET SPECIFIC REQUIREMENTS WITH SPECIAL STUDS AND/OR MOUNTING PLATE
 - LEGS MAY BE FURNISHED PACKAGED IN SETS OF FOUR WITH CUSTOMER'S PART NUMBER FOR KD SHIPPING



HEAVY-DUTY STAINLESS STEEL 2" (51mm) O.D. EQUIPMENT LEGS



HEAVY-DUTY STAINLESS STEEL 1-5/8" (41mm) O.D. EQUIPMENT LEGS

REF.	MODEL NO.	DESCRIPTION	HEIGHT
A	A84-5048-C	W/ REMOVABLE MOUNTING PLATE	6" (152mm)
B	A86-5048-C	W/ 3/4-10 PROTRUDING STUD	6" (152mm)
C	A85-9706-C	W/ 5/8-11 PROTRUDING STUD AND NON-MARKING BLACK NYLON FLANGED TOE	6" (152mm)

REF.	MODEL NO.	DESCRIPTION	HEIGHT
D	A48-5032-C	W/ REMOVABLE MOUNTING PLATE	4" (102mm)
	A48-5048-C	W/ REMOVABLE MOUNTING PLATE	6" (152mm)
E	A50-9704-C	W/ 1/2-13 PROTRUDING STUD & NON-MARKING BLACK NYLON FLANGED TOE	4" (102mm)
	A50-5032-C	W/ 1/2-13 PROTRUDING STUD	4" (102mm)
F	A50-5048-C	W/ 1/2-13 PROTRUDING STUD	6" (152mm)

MOUNTING PLATES HAVE (4) 5/16"(8mm) DIA. HOLES ON 2-5/8"(66mm) CENTERS.

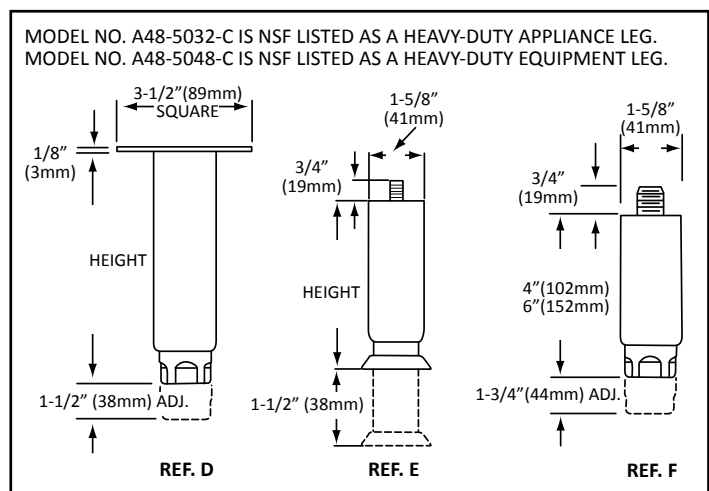
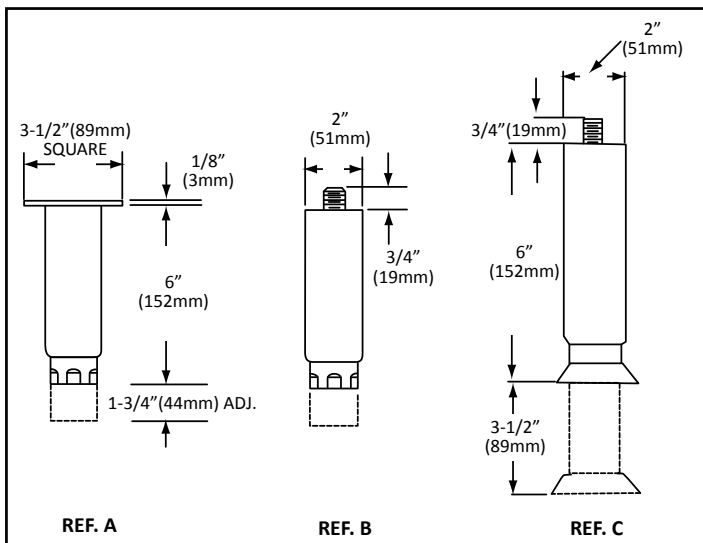

MODEL NO. A48-5032-C IS NSF LISTED AS A HEAVY-DUTY APPLIANCE LEG.
MODEL NO. A48-5048-C IS NSF LISTED AS A HEAVY-DUTY EQUIPMENT LEG.

SPECIFICATIONS

- MATERIAL:** 1-5/8" (41mm) AND 2" (51mm) O.D. STAINLESS STEEL TUBING
FINISH: #4 FINISH
STATIC LOAD RATING: 2000 lbs (900 kg) PER LEG

HEAVY-DUTY STAINLESS STEEL EQUIPMENT LEGS

- 1-5/8" (41mm) AND 2" (51mm) DIAMETER MODELS AVAILABLE IN 4" (102mm) AND 6" (152mm) HEIGHTS
- SUPPLIED WITH 3-1/2" (89mm) SQUARE REMOVABLE MOUNTING PLATE
- BLACK THERMOPLASTIC GLIDE REDUCES SCRATCHING OF COUNTERTOPS AND PROVIDES A CONTEMPORARY LOOK
- SATIN FINISH TO MATCH EQUIPMENT • 2000 lb (900 kg) STATIC LOAD RATING

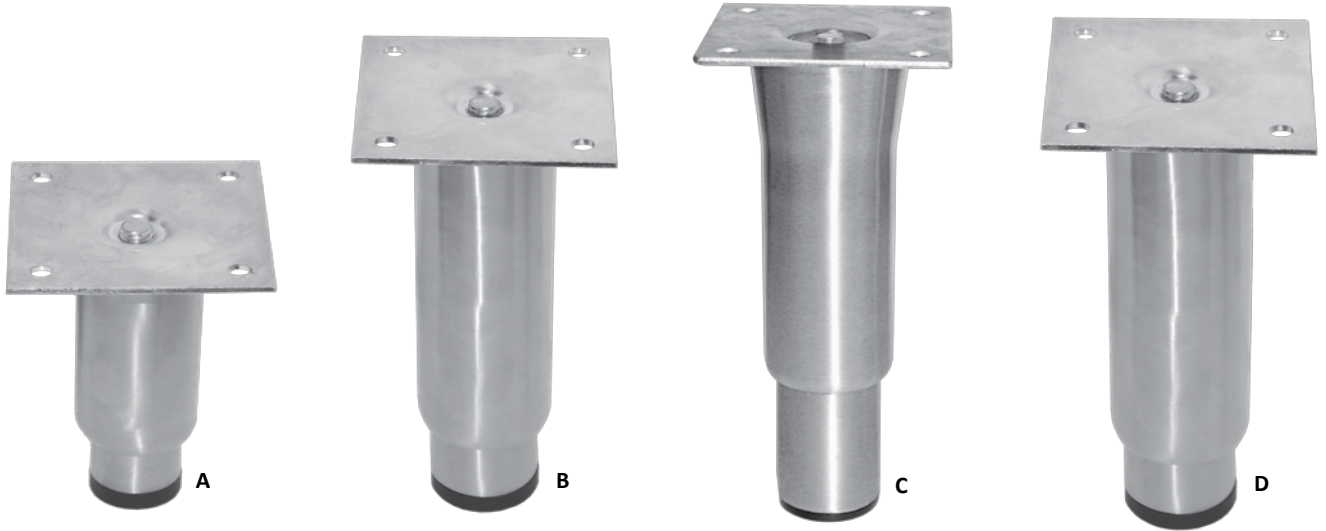

HEAVY-DUTY STAINLESS STEEL 1-5/8" (41mm) AND 2" (51mm) O.D. EQUIPMENT LEGS



REF.	MODEL NO.	DESCRIPTION	HEIGHT	O.D.
A	AB48-5032-C	W/ REMOVABLE 3-1/2" SQUARE MOUNTING PLATE	4" (102mm)	1-5/8" (42mm)
B	AB48-5048-C	W/ REMOVABLE 3-1/2" SQUARE MOUNTING PLATE	6" (152mm)	1-5/8" (42mm)
C	AB77-5048-C	W/ REMOVABLE 3-1/2" SQUARE MOUNTING PLATE	6" (152mm)	2" (51mm)
D	AB84-5048-C	W/ REMOVABLE 3-1/2" SQUARE MOUNTING PLATE	6" (152mm)	2" (51mm)

*SEE PAGE A26 FOR MOUNTING PLATE DETAILS

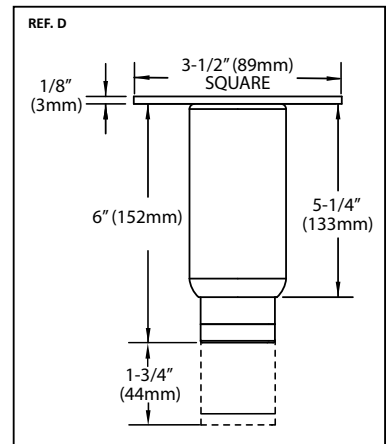
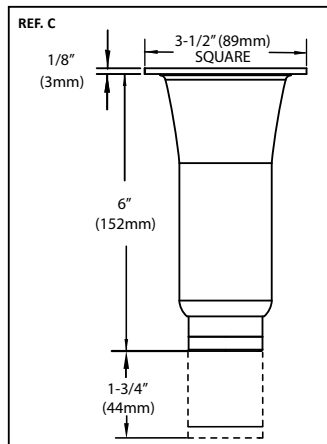
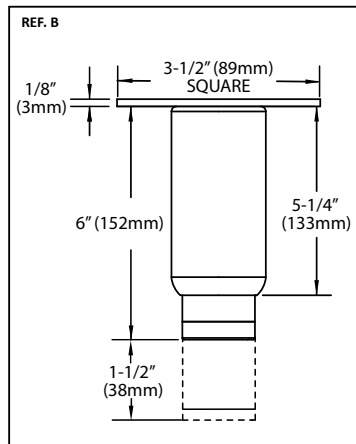
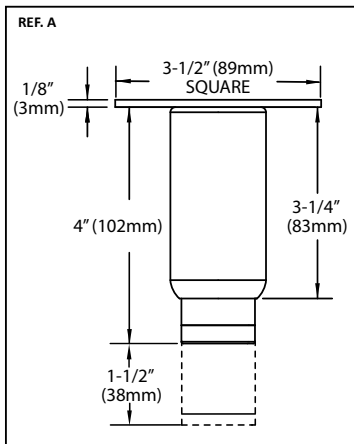

SPECIFICATIONS

MATERIAL: 1-5/8" (41mm) AND 2" (51mm) O.D. STAINLESS STEEL TUBING

FINISH: SATIN FINISH

STATIC LOAD RATING: 2000 lbs (900 kg) PER LEG

Stainless Steel Equipment Legs Feature Full 3" Adjustments

HEAVY-DUTY STAINLESS STEEL EQUIPMENT LEGS

- THREADED STEEL STUD, WELDED OR REMOVABLE MOUNTING PLATE PROVIDED FOR EASY MOUNTING OF LEGS TO EQUIPMENT
- ALL LEGS MAY BE FURNISHED TO MEET SPECIFIC REQUIREMENTS WITH SPECIAL STUDS AND/OR MOUNTING PLATES
- LEGS MAY BE FURNISHED PACKAGED IN SETS OF FOUR WITH CUSTOMER'S PART NUMBER FOR KD SHIPPING

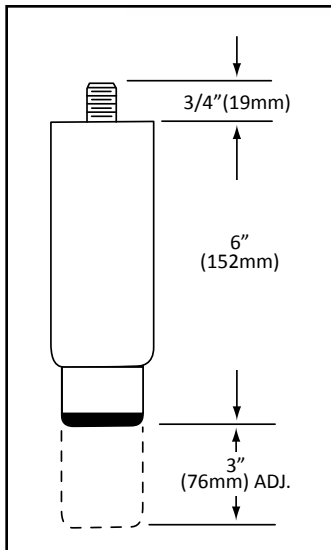

HEAVY-DUTY STAINLESS STEEL 2" (51mm) O.D. EQUIPMENT LEGS WITH FULL 3" (76mm) ADJUSTMENT

- NON-MARKING BLACK NYLON TOE available with...
- REMOVABLE MOUNTING PLATE
- WELDED MOUNTING PLATE
- PROTRUDING STUD

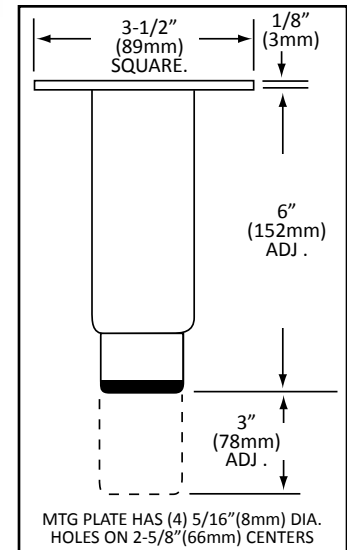

MODEL NO.	DESCRIPTION	HEIGHT
A92-8048-C	FURNISHED WITH WELDED MOUNTING PLATE	6" (152mm)
A93-8048-C	FURNISHED WITH REMOVABLE MOUNTING PLATE	6" (152mm)
A95-8048-C	FURNISHED WITH 3/4-10 PROTRUDING STUD	6" (152mm)

SPECIFICATIONS

MATERIAL: 2" (51mm) O.D. STAINLESS STEEL TUBING

FINISH: #4 SATIN FINISH

TOE ADJUSTMENT: LEGS ARE 6" (152mm) IN HEIGHT AND PROVIDE 3" (76mm) ADJUSTMENT

STATIC LOAD RATING: 2000 lbs (900 kg) PER LEG

Extra Wide Stainless Steel Clad Equipment Legs

2-1/2" OD HEAVY DUTY STAINLESS STEEL EQUIPMENT LEGS

- EXTRA WIDE 2-1/2" (64mm) DIAMETER PROVIDES A STABLE LEG BASE
- AVAILABLE WITH A 3/4"-10 FLUSH OR PROTRUDING STUD • FULL 2-1/2" HEIGHT ADJUSTMENT
- IDEAL FOR HEAVY RANGES, OVENS & FOOD PROCESSING EQUIPMENT

REF.	MODEL NO.	DESCRIPTION	HEIGHT
A	A67-5048-C	FURNISHED WITH 3/4"-10 FLUSH STUD	6" (152mm)
B	A68-5048-C	FURNISHED WITH 3/4"-10 PROTRUDING STUD	6" (152mm)
C	A44-X341-C	FURNISHED WITH 3-1/2" (89mm) SQUARE REMOVABLE MOUNTING PLATE	—

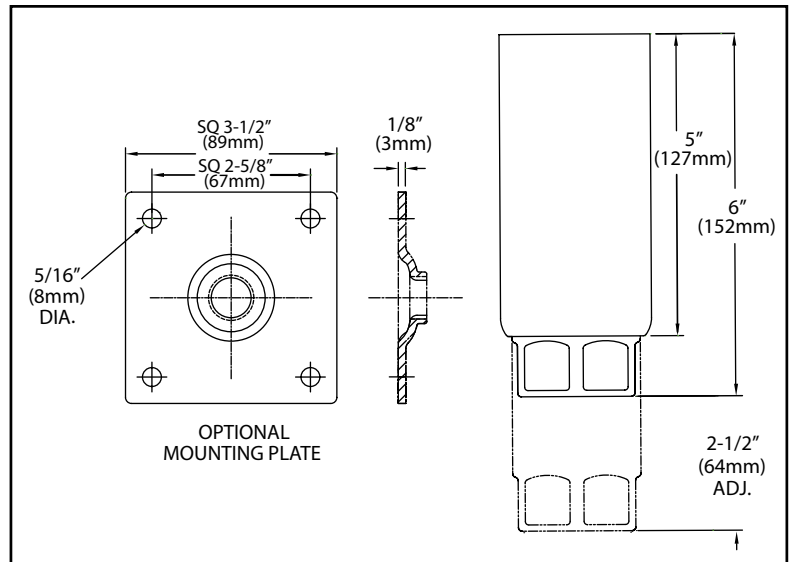
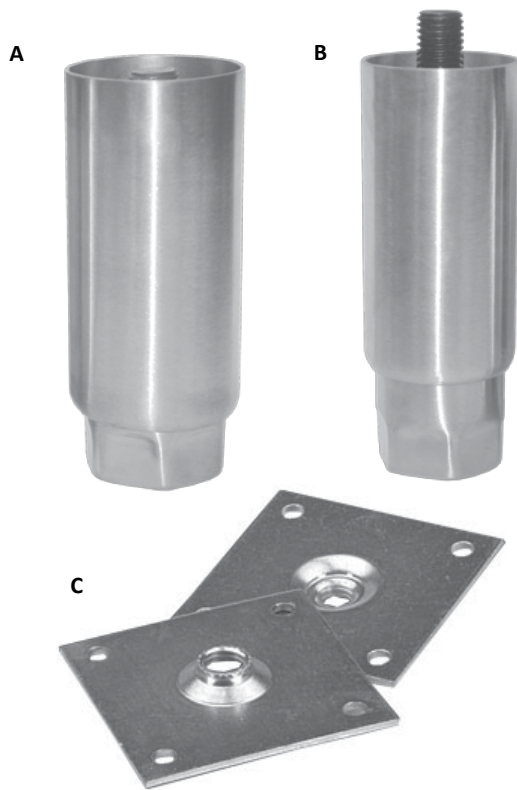

SPECIFICATIONS

- MATERIAL:** STAINLESS STEEL CONSTRUCTION
FINISH: SATIN FINISH
TOE ADJUSTMENT: LEGS ARE 6" (152mm) IN HEIGHT AND PROVIDE 2-1/2" (64mm) ADJUSTMENT
STATIC LOAD RATING: 2500 lbs PER LEG



CHROME PLATED EQUIPMENT LEG

MODEL NO. A99-9906-C

- ADJUSTABLE HEX FOOT IS STAINLESS STEEL CLAD
- MATCHES INDUSTRY STANDARD SPECIFICATION

SPECIFICATIONS

- MATERIAL:** CHROME PLATED STEEL CONSTRUCTION
FINISH: POLISHED CHROME
TOE ADJUSTMENT: LEGS ARE 6" (152mm) IN HEIGHT AND PROVIDE 1" (25mm) ADJUSTMENT
STATIC LOAD RATING: 2000 lbs (900 kg) PER LEG

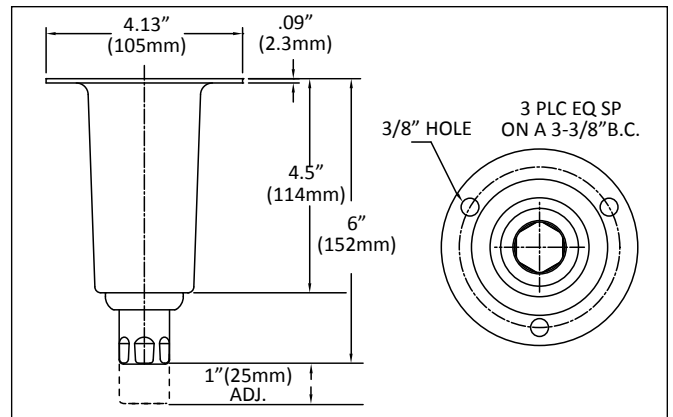

S/S One Piece Leg Assemblies With Full 3" Adjustment

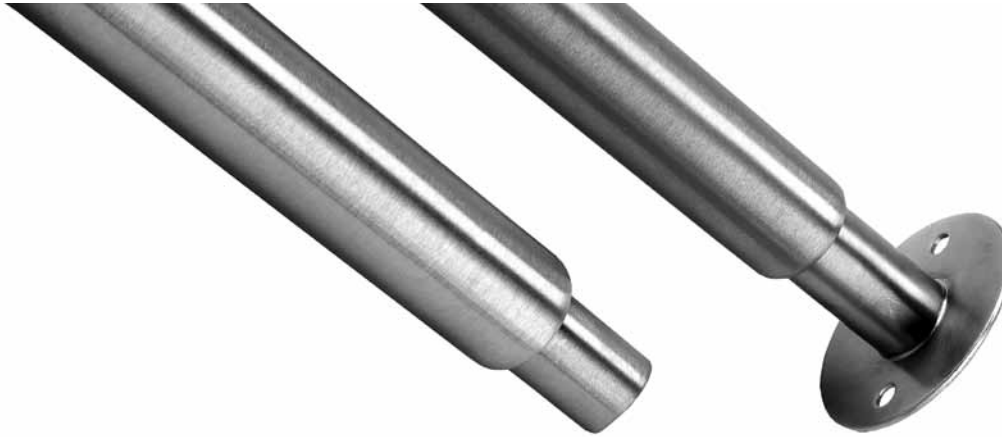

STAINLESS STEEL LEG ASSEMBLIES



1-5/8" (41mm) O.D. STAINLESS STEEL LEG ASSEMBLIES FULL 3" ADJUSTMENT FEATURE FOR STANDARD APPLICATIONS

- ECONOMICAL... ELIMINATES CUTTING, DEBURRING, POLISHING AND WASTE
- FULL 3" (76 mm) ADJUSTMENT • INDUSTRY STANDARD SIZES SHIPPED FROM STOCK
- EASILY CUT TO CUSTOM LENGTHS IN FABRICATOR'S SHOP • PERMITS KD SHIPMENT

- STANDARD PACKAGING 25 PER CARTON
- ALL LEGS MAY BE FURNISHED PACKAGED IN SETS OF FOUR.
IDENTIFIED WITH CUSTOMER PART NUMBER AS AN OPTION FOR KD SHIPPING.

MODELS WITH PLAIN TOP ADJUSTABLE ROUND TOE

MODEL NO.	LEG DIA.	LENGTH	TOE TYPE
A46-6048-C	1-5/8" (41mm)	6" (152mm)	ROUND
A46-6080-C	1-5/8" (41mm)	10" (254mm)	ROUND
A46-6160-C	1-5/8" (41mm)	20" (508mm)	ROUND
A46-6272-C	1-5/8" (41mm)	34" (864mm)	ROUND
A46-6288-C	1-5/8" (41mm)	36" (914mm)	ROUND

MODELS WITH PLAIN TOP AND 3-1/2" (89mm) DIA. FLANGED TOE WITH 2 MOUNTING HOLES*

MODEL NO.	LEG DIA.	LENGTH	TOE TYPE
A46-4048-C	1-5/8" (41mm)	6" (152mm)	3-1/2" (89mm) DIA. S/S FLANGE
A46-4080-C	1-5/8" (41mm)	10" (254mm)	3-1/2" (89mm) DIA. S/S FLANGE
A46-4160-C	1-5/8" (41mm)	20" (508mm)	3-1/2" (89mm) DIA. S/S FLANGE
A46-4272-C	1-5/8" (41mm)	34" (864mm)	3-1/2" (89mm) DIA. S/S FLANGE
A46-4288-C	1-5/8" (41mm)	36" (914mm)	3-1/2" (89mm) DIA. S/S FLANGE

*NOTE: FLANGED FOOT MODELS HAVE 3-1/2" (89mm) O.D., 12 GA (2.6mm) STAINLESS STEEL FLANGE WITH A #4 SATIN FINISH, AND (2) 11/32" (9mm) DIA. MTG. HOLES SPACED 2-1/2" (64mm) O.C.

SPECIFICATIONS

- MATERIAL:** 1-5/8" (41mm) DIA., 16 ga (1.5mm) STAINLESS STEEL TUBING
- FINISH:** #4 SATIN FINISH
- TOE ADJUSTMENT:** 3" (76mm) MINIMUM
- STATIC LOAD RATING:** 2000 lbs (900 kg) PER LEG

Custom Stainless Steel Leg Assemblies



STAINLESS STEEL
1-5/8" (41mm) & 2" (51mm) O.D.

LEG ASSEMBLIES FOR CUSTOM APPLICATIONS

- ALL LENGTHS FROM 4" (102mm) to 36" (914mm)
- CHOOSE FROM ARRAY OF OPTIONAL TOPS AND ADJUSTABLE TOES
- PERMITS KD SHIPMENT

SPECIFICATIONS

MATERIAL: 16 ga (1.5 mm) STAINLESS STEEL TUBING
FINISH: #4 SATIN FINISH
TOE ADJUSTMENT: 1-1/2" (40mm) MINIMUM
MOUNTING PLATES: 11 ga (3mm) PLATED STEEL, 3-1/2" (89mm) SQUARE WITH (4) 5/16" (8mm) DIA. HOLES SPACED ON 2-5/8" (66mm) CENTERS
STATIC LOAD RATING: 2,000 lbs PER LEG









NON-STOCK ITEMS... CALL FOR LEAD TIME
STANDARD PACKAGING...25 PER CARTON

ALL LEGS MAY BE FURNISHED PACKAGED IN SETS OF FOUR, IDENTIFIED WITH CUSTOMER PART NUMBER, ETC.

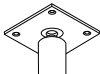
LEG ASSEMBLIES FOR CUSTOM APPLICATION

ORDERING INFORMATION FOR 1-5/8" (41mm) & 2" (51mm) O.D. LEG ASSEMBLIES

FOR 1-5/8" (41 mm) O.D. LEG ASSEMBLIES USE PREFIX...A46 THRU A50 (SHOWN SHADED PURPLE ON CHART).
 FOR 2" (51 mm) O.D. LEG ASSEMBLIES USE PREFIX...A52 THRU A56.

		CUSTOM LEG TOPS AVAILABLE				
		PLAIN	WELDED PLATE	REMOVABLE PLATE	FLUSH 1/2-13 STUD	PROTRUDING 1/2-13 STUD
OPTIONAL TOES AVAILABLE						
FLANGED NO HOLES 	A46-3__	A47-3__	A48-3__	A49-3__	A50-3__	
	A52-3__	A53-3__	A54-3__	A55-3__	A56-3__	
FLANGED WITH HOLES 	A46-4__	A47-4__	A48-4__	A49-4__	A50-4__	
	A52-4__	A53-4__	A54-4__	A55-4__	A56-4__	
S/S/ HEX 	A46-5__	A47-5__	A48-5__	A49-5__	A50-5__	
	A52-5__	A53-5__	A54-5__	A55-5__	A56-5__	
S/S ROUND 	A46-6__	A47-6__	A48-6__	A49-6__	A50-6__	
	ROUND FOOT INSERTS NOT AVAILABLE FOR 2" (51mm) DIA. LEG ASSEMBLIES					

TO ORDER: SIMPLY SPECIFY LEG TOP AND ADJUSTABLE TOE DESIRED TOGETHER WITH THE LENGTH IN INCHES REQUIRED.

EXAMPLE: 1-5/8" (41mm) O.D. WITH PLAIN TOP...SPECIFY A46 NYLON TIP...SPECIFY -2 24" (610mm) LENGTH...SPECIFY 24" (610mm). THE PART NUMBERS IN THE CHART PROVIDE BLANKS TO ACCOMMODATE ANY LENGTH OF LEG BETWEEN 4" (102mm) AND 36" (914mm) IN 1/8" (3mm) INCREMENTS. COMPONENT HARDWARE WILL USE THESE BLANKS TO CONVERT YOUR INDIVIDUAL DESIGN AND LENGTH REQUIREMENT INTO ITS OWN PART NUMBER.

ORDER FORM-CUSTOM STAINLESS STEEL H-FRAME ASSEMBLY

AH46 SERIES CUSTOM STAINLESS STEEL H-FRAME ASSEMBLY

- 16 GAUGE STAINLESS STEEL
- 1-5/8" O.D. UPRIGHTS WITH 1-1/4" O.D. CROSS MEMBER
- COMPLETELY WELDED AND POLISHED
- SATIN FINISH
- ECONOMICAL
- CONVENIENT
- WIDE ARRAY OF POP-IN ADJUSTABLE FOOT INSERTS AVAILABLE
- PACKED TWO/CARTON FOR EASY KD SHIPMENT
- NON-STOCK (90-120 DAYS DELIVERY)
- QUANTITY ORDERS ONLY
- MUST SPECIFY DIMENSIONS A, B, C WHEN ORDERING

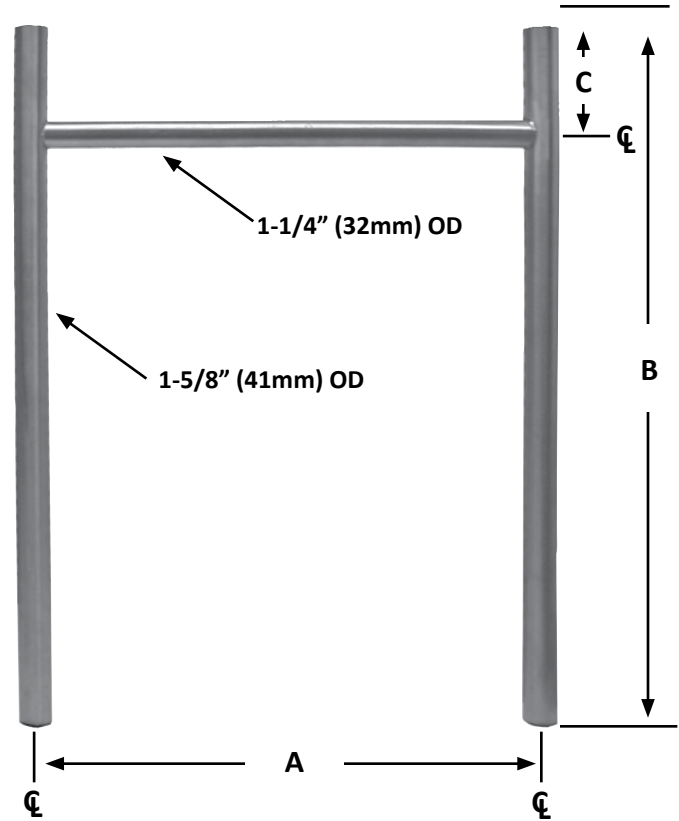

TOE OPTIONS



- STAINLESS STEEL HEX
A10-0851-C
- STAINLESS STEEL ROUND
A10-0852-C
- PLASTIC HEX (BLACK)
A10-0831-C
- PLASTIC HEX (GRAY)
A10-0841-C
- METAL DIE CAST HEX
A10-0811-C
- S/S 3" ADJUSTABLE HEX
A10-0881-C



STAINLESS STEEL
FLANGED (NO HOLES)
A10-0853-C



STAINLESS STEEL
FLANGED (WITH HOLES)
A10-0854-C
3" ADJUSTABLE
A10-0884-C

To Order:

Company Name _____

Contact Person _____

Address _____

Purchase Order No. _____

Phone/email _____

QTY	A-DIM	B-DIM	C-DIM

ADJ. FOOT *Please indicate none if no feet are required

Return completed information to CHG, or contact us.

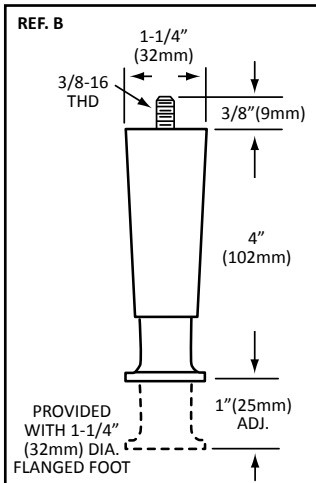
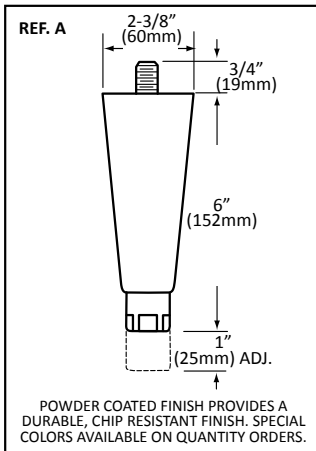

ALUMINUM APPLIANCE LEGS

- ALUMINUM DIE CAST CONSTRUCTION PROVIDES OUTSTANDING PERFORMANCE AT AN AFFORDABLE PRICE
- AVAILABLE FOR 6" EQUIPMENT LEG AND 4" APPLIANCE LEG APPLICATIONS

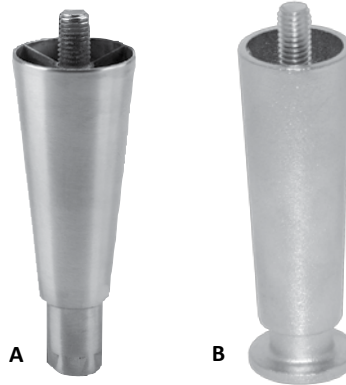

REF.	MODEL NO.	FINISH	TYPE	HEIGHT	ADJ.	LOAD RATING LBS/FOOT(KG/MM)	THREAD
A	AA61-4002-C	NICKEL	HEX	6" (152mm)	1" (25mm)	2000 lbs (900 kg)	1/2-13 PROTRUDING
A	AA62-5002-C	NICKEL	S/S HEX	6" (152mm)	1" (25mm)	2000 lbs (900 kg)	5/8-11 PROTRUDING
B	AAE60-1653	NICKEL	FLANGE	4" (102mm)	1" (25mm)	2000 lbs (900 kg)	3/8-16 PROTRUDING

HEAVY DUTY S/S APPLIANCE LEG

- 4" (102mm) HIGH
- 1/2" (51mm) DIA. FLANGE WITH PLASTIC GLIDE
- CONTEMPORARY DESIGN
- IDEAL FOR COFFEE MACHINES AND BEVERAGE DISPENSERS
- SATIN FINISH

MODEL NO. A99-9940-C



SKID RESISTANT APPLIANCE LEG

- IDEAL FOR BEVERAGE DISPENSERS AND OTHER LARGE COUNTERTOP APPLIANCES
- 4" (102mm) HIGH • BLACK THERMOPLASTIC FINISH • STATIC LOAD CAPACITY 200 LBS
- SPECIALLY ENGINEERED SLIP RESISTANT BLACK RUBBER FLANGED TOE COMPRESSES THE RUBBER FLANGE UNDER LOAD TO MINIMIZE LEG SLIPPAGE ON VARIOUS WORK SURFACES • PATENT PENDING

MODEL NO. A60-0633-R

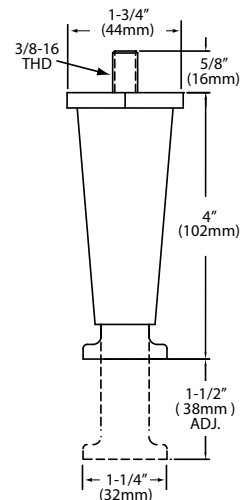

Appliance Legs



APPLIANCE LEGS

4" (102mm) HIGH APPLIANCE LEGS

- THERMOPLASTIC
BLACK, GRAY or CHROME PLATED

STATIC LOAD CAPACITY 200 lbs

REF.	MODEL NO.	FINISH	FOOT TYPE
A	A60-0631	BLACK	HEX
B	A60-0641	GRAY	HEX
C	A60-0623	CHROME	FLANGE
D	A60-0633	BLACK	FLANGE

LEG TYPE	*A	B
A60-16XX SERIES	1-7/16" (37mm)	3/8" (9mm)
A60-06XX SERIES	1-3/4" (44mm)	5/8" (16mm)

*ACROSS HEX CORNERS

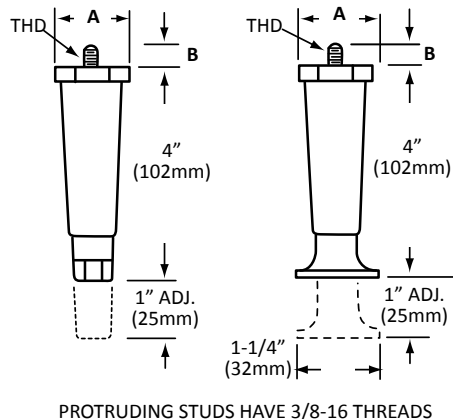

4" (102mm) HIGH APPLIANCE LEGS

- DIE CAST METAL with
SATIN NICKEL FINISH

STATIC LOAD CAPACITY 250 lbs

REF.	MODEL NO.	FINISH	FOOT TYPE
E	A60-1651	SATIN NICKEL	HEX
F	A60-1653	SATIN NICKEL	FLANGE

2-1/2" (63mm) HIGH APPLIANCE LEGS

- THERMOPLASTIC
BLACK or GRAY

STATIC LOAD CAPACITY 200 lbs

REF.	MODEL NO.	FINISH	FOOT TYPE
G	A60-0431	BLACK	HEX
H	A60-0441	GRAY	HEX

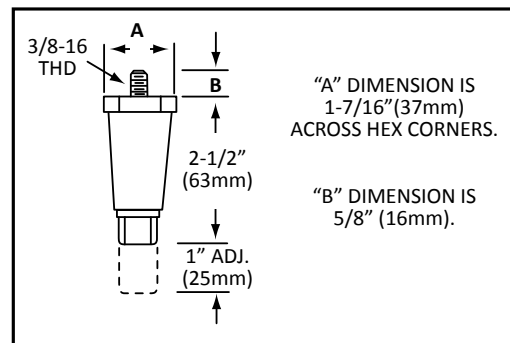

OPTIONAL NON-SKID PADS AVAILABLE: FOR A60 SERIES HEX TOE - SPECIFY MODEL NO. A60-X003
FOR A60 SERIES FLANGED TOE - SPECIFY MODEL NO. A60-X001

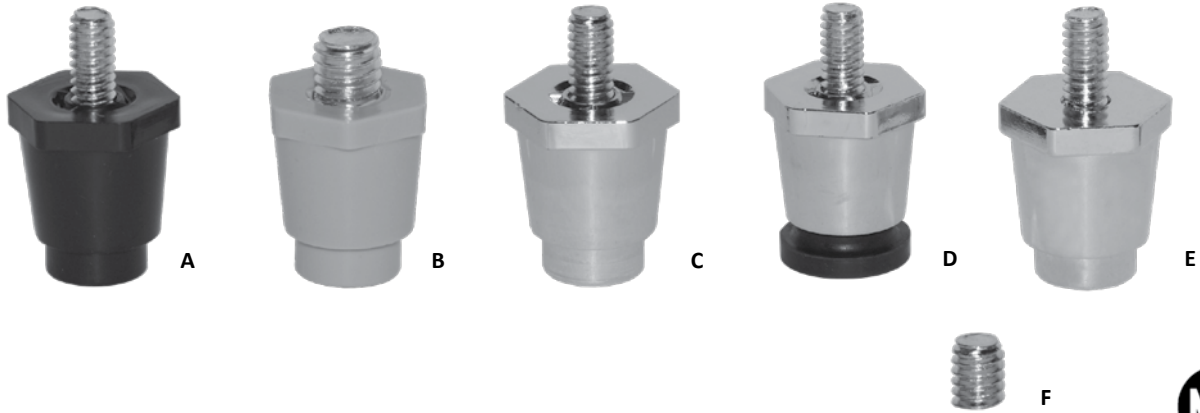

APPLIANCE LEGS



1" (25mm) HIGH THERMOPLASTIC APPLIANCE LEGS

STATIC LOAD CAPACITY 100 lbs

REF.	MODEL NO.	FINISH	FOOT TYPE
A	A60-2205	BLACK	ROUND
B	A60-2210*	GRAY	ROUND
C	A60-2305	CHROME	ROUND
D	A60-2405	CHROME	BLACK RUBBER FLANGE

*FURNISHED WITH 3/8 - 16

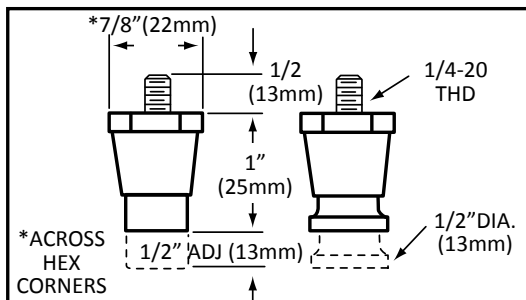

REF. E

1" (25mm) HIGH ZAMAK APPLIANCE LEG

• HEAT RESISTANT

STATIC LOAD CAPACITY 200 lbs

MODEL NO.	FINISH	FOOT TYPE
A60-2105	CHROME	ROUND

REF. F

THREAD CONVERTER

EASILY SCREWS ON EXISTING APPLIANCE LEG TO CONVERT 1/4-20 PROTRUDING STUD THREAD TO A 3/8-16 THREAD

MODEL NO. A60-1438

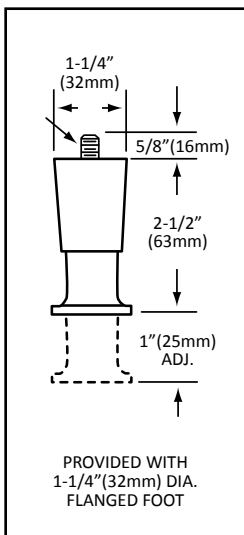
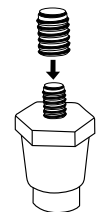

2-1/2" (63mm) HIGH ECONOMY SERIES APPLIANCE LEGS

- DIE CAST ZAMAK with NICKEL PLATED POLISHED FINISH
- FLANGE FOOT
- 2000 lbs (900 kg) STATIC LOAD CAPACITY PER LEG

MODEL NO.
AE60-1453



4" (102mm) HIGH ECONOMY SERIES APPLIANCE LEGS

- DIE CAST ZAMAK with NICKEL PLATED MATTE FINISH
- FLANGE FOOT
- 2000 lbs (900 kg) STATIC LOAD CAPACITY PER LEG

MODEL NO.
AE60-1653

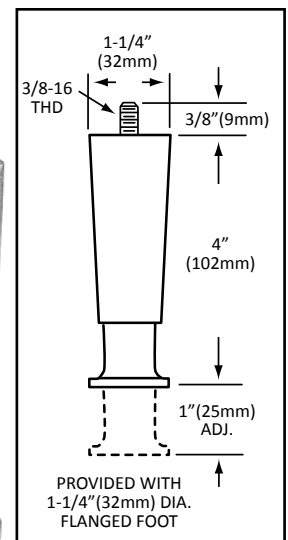

OPTIONAL NON-SKID FOOT PADS AVAILABLE
SPECIFY - MODEL NO. AE60-X010 FOR GREY SILICONE



Appliance Legs



4" (102mm) HIGH EQUIPMENT LEG

- NICKEL PLATED ZAMAK • 1-1/4" (32mm) ADJUSTMENT
- 1/2-13 x 1/2" MOUNTING STUD
- HEX TOE FOR EASY FIELD ADJUSTMENT
- SATIN FINISH
- STATIC LOAD CAPACITY 2000 lbs

MODEL NO.	FINISH	FOOT TYPE
AE41-4002-C	SATIN NICKEL	HEX

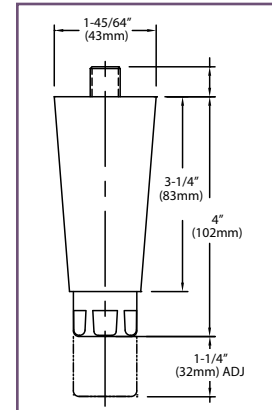

4" (102mm) HIGH HEAVY DUTY APPLIANCE LEGS

- DESIGNED FOR LARGE COUNTERTOP APPLIANCES
- DIE CAST ZAMAK ADJUSTABLE FLANGE FOOT • OPTIONAL NON-SKID FOOT PADS AVAILABLE
- ROUGH, RUGGED THERMOPLASTIC BODY WITH STEEL STUD
- WRENCH FLATS FOR EASY INSTALLATION AND ADJUSTMENT • CHOICE OF BLACK OR NICKEL PLATED MATTE FINISHES
- 2000 lbs (900 kg) STATIC LOAD CAPACITY PER LEG

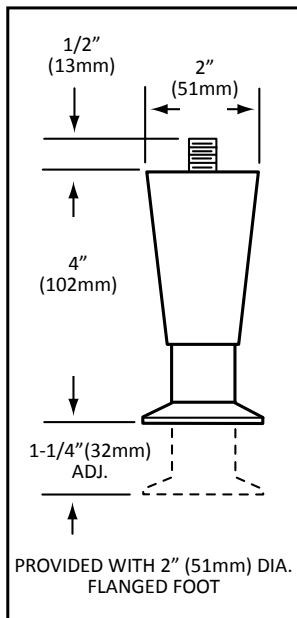

MODEL NO.	MOUNTING STUD	DESCRIPTION
A70-1000	1/2-13 PROTRUDING	MATTE BLACK THERMOPLASTIC BODY with MATTE NICKEL PLATED ZAMAK FLANGED FOOT
A70-1010	1/2-13 FLUSH	
A70-1020	3/8-16 PROTRUDING	
A70-1010-M	M12 FLUSH	MATTE NICKEL PLATED THERMOPLASTIC BODY with MATTE NICKEL PLATED ZAMAK FLANGED FOOT
A70-2000	1/2-13 PROTRUDING	
A70-2010	1/2-13 FLUSH	
A70-2020	3/8-16 PROTRUDING	
A70-2000-M	M12 PROTRUDING	
A70-2010-M	M12 FLUSH	HI-TEMP THERMOPLASTIC RATED TO 300°F CONSTANT, 350°F INTERMITTENT
A71-1020	3/8-16 PROTRUDING	

NOTE: OPTIONAL NON-SKID NEOPRENE FOOT PADS AVAILABLE
SPECIFY MODEL NO. A70-X011 WHEN ORDERING



CROSS BRACE FITTINGS

FOR 1-1/2" (38mm) O.D. LEGS and 1-5/8" (41mm) O.D. LEGS

Designed to mate 1-1/2" (38mm) and 1-5/8" (41mm) O.D. vertical legs with 1-1/4" (32mm) O.D. horizontal cross rails. These die cast aluminum CROSS BRACE FITTINGS eliminate notching, welding and polishing. Ideal for knock-down shipping.

END CROSS BRACE FITTING
MODEL NO. A35-2020
 TO SUIT 1-1/2" (38mm) VERTICAL LEGS
MODEL NO. A35-1020
 TO SUIT 1-5/8" (41mm) VERTICAL LEGS

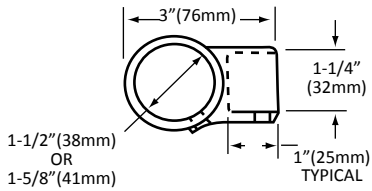

CORNER CROSS BRACE FITTING
MODEL NO. A35-2010
 TO SUIT 1-1/2" (38mm) VERTICAL LEGS
MODEL NO. A35-1010
 TO SUIT 1-5/8" (41mm) VERTICAL LEGS

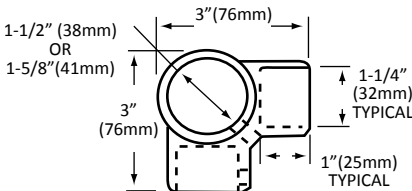

CENTER CROSS BRACE FITTING
MODEL NO. A35-2030
 TO SUIT 1-1/2" (38mm) VERTICAL LEGS
MODEL NO. A35-1030
 TO SUIT 1-5/8" (41mm) VERTICAL LEGS

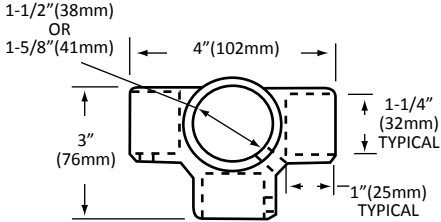

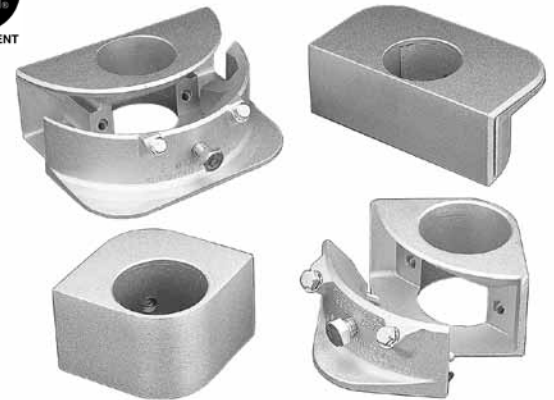

QUICK CORNER™ BRACKETS
FOR ADJUSTABLE UNDERSHELVES
FOR 1-1/2" (38mm) O.D. LEGS and 1-5/8" (41mm) O.D. LEGS

QUICK CORNER BRACKETS are pre-finished die cast aluminum components. They are easily fastened to pre-notched sheet metal undershelves to provide strong, secure, rigid undershelf support assemblies. Adjusting screws are provided for setting the undershelf to any desired height. Welding, grinding and polishing is eliminated and knock-down shipping is facilitated.

Corner and center brackets are designed for either 1-1/2" (38mm) or 1-5/8" (41mm), O.D. tubing. Notching diagrams are provided with installation instructions.

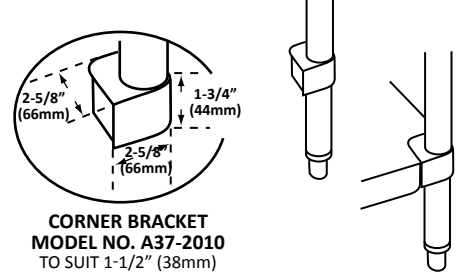

CORNER BRACKET
MODEL NO. A37-2010
 TO SUIT 1-1/2" (38mm)
MODEL NO. A37-1010
 TO SUIT 1-5/8" (41mm)

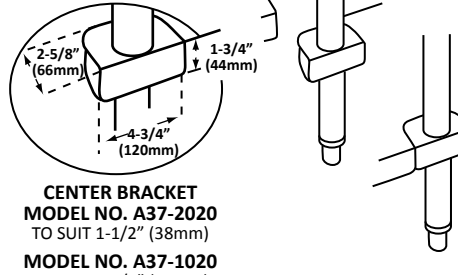

CENTER BRACKET
MODEL NO. A37-2020
 TO SUIT 1-1/2" (38mm)
MODEL NO. A37-1020
 TO SUIT 1-5/8" (41mm)

NSF STANDARDS GOVERNING THE USE OF SET SCREWS IN NON-FOOD ZONES REQUIRES THE PLUGGING OF THE HEX SOCKET HOLE AFTER FINAL ASSEMBLY AND TIGHTENING. THIS MAY BE ACCOMPLISHED BY APPLYING A HARDENING TYPE SILICONE SEALANT OR THE USE OF A HOLE PLUG. STANDARD NSF TYPE PUSH-IN PLASTIC HOLE PLUGS ARE AVAILABLE. SPECIFY A10-0020 WHEN ORDERING, SEE PAGE A24.

Accessories

REMOVABLE MOUNTING PLATES

- 11 ga (3mm) ZINC PLATED STEEL

SQUARE MOUNTING PLATES

3-1/2" x 3-1/2"
(89mm x 89mm)

MODEL NO. A44-X301-C
(1/2-13 TH'D)

MODEL NO. A44-X309-C
(5/8-11 TH'D)

MODEL NO. A44-X341-C
(3/4-10 TH'D)

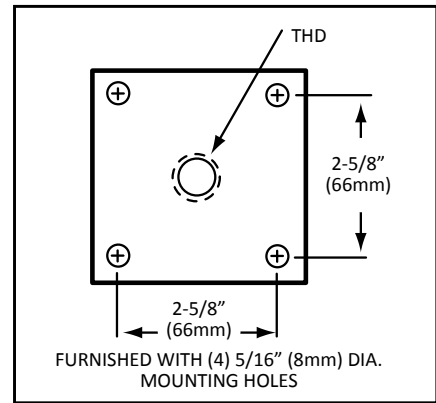

RECTANGULAR MOUNTING PLATES

2-1/2" x 3-5/8"
(63mm x 92mm)

MODEL NO. A44-X327-C

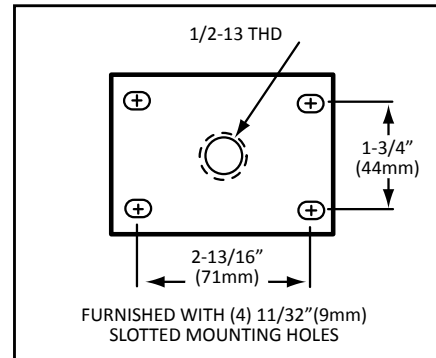

REMOVABLE/CONCEALED UNDERSHELF BRACKETS

- NICKEL PLATED STEEL
- FITS 1-5/8" (38mm) O.D. TUBING

CORNER BRACKET
MODEL NO. A34-1010

CENTER BRACKET
MODEL NO. A34-1012

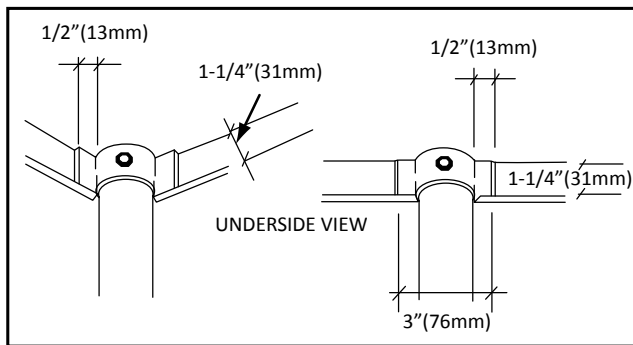
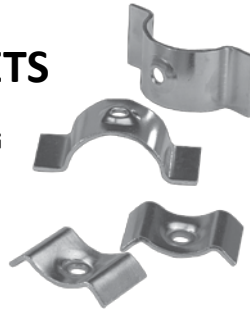

BRACKETS PROVIDED WITH 5/16" (8mm) DIA. HOLE



MODEL NO.
A60-2724

500lbs load capacity
per glide

ADJUSTABLE FOOT LEVELERS

- NON-MARKING



MODEL NO.
A60-4444

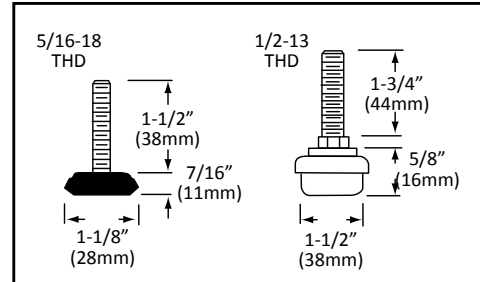

SET SCREW HOLE PLUGS

MODEL NO. A10-0020

TO COMPLY WITH NSF REQUIREMENTS...
ALL SET SCREW SOCKET OPENINGS
MUST BE PLUGGED AFTER FINAL ASSEMBLY
AND TIGHTENING

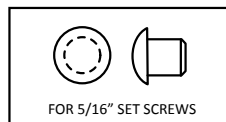
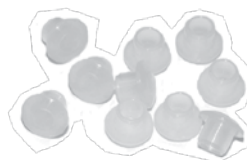

KICK PLATE SPRING CLAMP

MODEL NO. A76-4460

- FITS ON 1-1/4" PIPE, 1-5/8" (41mm) and 2" (51mm) O.D. TUBING
- ZINC PLATED STEEL

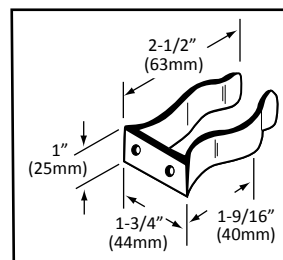

MODEL NO.	PAGE NO.	MODEL NO.	PAGE NO.	MODEL NO.	PAGE NO.	MODEL NO.	PAGE NO.	MODEL NO.	PAGE NO.
A10-0010-C	A3, A4, A5	A46-4160-C	A16	AB48-5048-C	A13				
A10-0020	A23, A24	A46-4272-C	A16	AB77-5048-C	A13				
A10-0221-C	A3	A46-4288-C	A16	AB84-5048-C	A13				
A10-0421-C	A3	A46-6048-C	A16	AE41-4002-C	A22				
A10-0611-C	A3	A46-6080-C	A16	AE60-1453	A21				
A10-0631-C	A3	A46-6160-C	A16	AE60-1653	A21				
A10-0641-C	A3	A46-6272-C	A16	AE61-2003-C	A10				
A10-0651-C	A3	A46-6288-C	A16	AE61-2104-C	A10				
A10-0654-C	A7	A47-9932-C	A8	AE61-4002-C	A10				
A10-0811-C	A3, A18	A48-5032-C	A12	AE61-5002-C	A10				
A10-0831-C	A3, A18	A48-5048-C	A12	AE62-2104-C	A10				
A10-0841-C	A3, A18	A50-5032-C	A12	AE62-4002-C	A10				
A10-0851-C	A3, A18	A50-5048-C	A12	AE62-5002-C	A10				
A10-0852-C	A3, A18	A50-9704-C	A12	AE63-2003-C	A10				
A10-0852-S	A4	A50-9939-C	A8	AE63-2104-C	A10				
A10-0853-C	A7, A18	A52-9907-C	A11	AE63-4002-C	A10				
A10-0854-C	A7, A18	A60-0431	A20	AE63-5002-C	A10				
A10-0881-C	A5, A18	A60-0441	A20	AP61-4003-C	A9				
A10-0884-C	A5, A18	A60-0623	A20	AP62-4003-C	A9				
A10-1000	A4	A60-0631	A20	AP63-2003-C	A9				
A10-1500	A4	A60-0633	A20	AP63-4003-C	A9				
A10-9904-C	A7	A60-0633-R	A19	AP64-4003-C	A9				
A11-0851-C	A3	A60-0641	A20	LSB-158	A1				
A11-0854-C	A7	A60-1438	A21						
A14-0221-C	A6	A60-1651	A20						
A14-0224-C	A7	A60-1653	A20						
A14-0411-C	A6	A60-2105	A21						
A14-0421-C	A6	A60-2205	A21						
A14-0424-C	A7	A60-2210	A21						
A14-0611-C	A6	A60-2305	A21						
A14-0651-C	A6	A60-2405	A21						
A14-0653-C	A7	A60-2724	A24						
A14-0654-C	A7	A60-4444	A24						
A15-0851-C	A6	A60-X001	A20						
A15-0854-C	A7	A60-X003	A20						
A16-0206-C	A2	A67-5048-C	A15						
A18-0202-C	A2	A68-5048-C	A15						
A18-0203-C	A2	A70-1000	A22						
A18-0206-C	A2	A70-1010	A22						
A18-0402-C	A2	A70-1020	A22						
A18-0406-C	A2	A70-1010-M	A22						
A18-9900-C	A2	A70-2000	A22						
A18-X001	A1, A2	A70-2010	A22						
A19-1000	A1	A70-2020	A22						
A20-0206-C	A2	A70-2000-M	A22						
A20-0406-C	A2	A70-2010-M	A22						
A24-0206-C	A1	A70-X011	A22						
A24-0207-C	A1	A71-1020	A22						
A26-0207-C	A1	A72-0811	A11						
A28-0207-C	A1	A76-4460	A24						
A34-1010	A24	A77-5048-C	A11						
A34-1012	A24	A78-5048-C	A11						
A35-1010	A23	A79-5048-C	A11						
A35-1020	A23	A84-5048-C	A12						
A35-1030	A23	A85-9706-C	A12						
A35-2010	A23	A86-5048-C	A12						
A35-2020	A23	A88-9902-C	A8						
A35-2030	A23	A90-9902-C	A8						
A37-1010	A23	A92-8048-C	A14						
A37-1020	A23	A93-8048-C	A14						
A37-2010	A23	A95-8048-C	A14						
A37-2020	A23	A99-9906-C	A15						
A44-X301-C	A24	A99-9940-C	A19						
A44-X309-C	A24	AA61-4002-C	A19						
A44-X327-C	A24	AA62-5002-C	A19						
A44-X341-C	A15, A24	AAE60-1653	A19						
A46-4048-C	A16	AE60-X010	A21						
A46-4080-C	A16	AB48-5032-C	A13						



COMPONENT
HARDWARE

1890 Swarthmore Avenue • PO Box 2020 • Lakewood • NJ 08701
Tel. 800-526-3694 • 732-363-4700 • Fax 732-364-8110
www.componenthardware.com

